

Digital Video Player



Circuit Description and Troubleshooting

Course: DVD-02

Course Description and Troubleshooting:

Model: DVP-S530D

Prepared by: National Training Department
Sony Service Company
A Division of Sony Electronics Inc.

Course presented by _____

Date _____

Student Name _____

Sony Service Company
A Division of Sony Electronics Inc ©1999
All Rights Reserved
Printed in U.S.A.

“DTS” is a trademark of Digital Theater Systems, Inc.
“AC-3” is a trademark of Dolby Laboratories Licensing Corporation.
“Dolby” and “Dolby Surround” are trademarks of Dolby Laboratories
Licensing Corporation.
“Sony” and “Digital Cinema Sound” are trademarks of Sony.
“THX” is a trademark of Lucasfilm, Ltd.

Table of Contents

Introduction to the DTS Audio Format	1	Regulation Concept	13
What is DTS?	2	Regulation Circuitry	13
What do I need to play the DTS surround format?	2	Main Oscillator	15
What do I need to play both the AC-3 and DTS surround formats?	2	Enable	15
Will a 5.1 channel DTS CD play in my CD player?	2	Start	15
Why won't my older DVD player play DTS DVDs?	3	Run	15
Can DVD movies contain both DTS and AC-3 audio tracks?	3	Regulation	15
How does DTS work?	3	Power Control	17
Board Layout	5	Plug In	17
DVD Features	6	Communications Block	21
Block Diagram	7	Serial Data	21
Power Supply	7	Parallel Data	21
Communications	7	Serial Data Communications	23
Servo Control	7	Serial Bus 0	23
Video and Audio Processing	9	Serial Bus 1	25
Power Supply Block	11	Parallel Data Communications	27
Standby Power Supply	11	Communications from IC202 to Other ICs	29
Main Power Supply	11	Communications from a Destination IC to IC202	29
Power Consumption	11	Mechanism	31
Oscillator Frequencies	11	Disc Tray and Laser Platform Position	31
Standby Oscillator	13	Tilt Motor	32
Start	13	Power ON Mechanical Sequence - No Disc	34
Run	13	Power ON Mechanical Sequence - DVD Disc	35
		Tray Motor Drive	37

Initial Sled Motor Drive	41	Manually Driving the Tilt Motor	71
Initial Sled Movement	41	A/V Processing Block	73
Home Position Detection	45	A/V Processing	75
Laser Servo	47	Test Mode	81
KHM-220A DVD Optical Block	49	Test Mode Access	81
DVD Focus	49	Tests	81
CD Focus	49	Additional Test Mode	83
Three Laser Beams from One Laser	50	Self-Diagnostic Function (Customer Error Codes)	83
Photo Detectors	51	Troubleshooting	85
Disc Identification	53	General Problems and Troubleshooting Guide	85
Operation	53		
SACD Disc Type	53		
Focus	55		
Search	55		
Servo	55		
Focus Drive	57		
Focus Search Communications	57		
Spindle Motor	61		
Kick Mode	61		
CLV PB Mode	63		
Tracking Servo	65		
Tracking Counting in Pause or Picture Jump	65		
Sled Motor Drive - PB	67		
Following the Track	59		
Tilt Servo	69		
Operation	69		

Introduction to the DTS Audio Format

Several major consumer audio formats that exist today are listed in this table:

Audio Formats								
Format (note 1)	Year Used	Chan-nels	Class	Typical sample	Typical Data Rate (note 2)	Compression (Approx.)	Test Disc	Signal Source (note 3)
1. Stereo	1933	2	Analog	linear				FM, VHS, CD, LD, etc.
2. PCM (digital version of stereo)		2	Digital	16 bits / sample.	705kbit/sec (44.1kHz sample)	None		DVD, LD
3. Dolby Surround ®	1982	3	Analog			None		VHS
4. Dolby Prologic ®	1987	4	Analog			None	Prologic test CD Dolby DVD-TEST1	VHS, theaters
5. Dolby Digital ®	1991	6	Digital	20 bits / sample	384 Kbytes/sec (44.1kHz sample)	90%	Dolby DVD-TEST1	DVD, LD, DTV
6. DTS ®	1993	6	Digital	20 bits / sample	1,411kbits/sec (44.1kHz sample)	75%	DTS Test CD DTS Test DVD	DVD, LD, CD
7. THX ®	1982	2-6	Either					Theaters, DVD, LD, VHS

Note 1 - All formats require decoders, except Stereo and THX. THX is not a processing system but an audio/video quality control approval system. Its certification stamp means that the video and audio quality at theaters and CD/DVD discs meet uniform standards. This means the same movie viewed at one theater will not be different when viewing it at another theater.

Note 2 - Data rate = bits sampled X sample rate. A CD player (44.1kHz) rate was chosen for comparison. The DVD sample rate of 48kHz would make its data rate higher than shown.

Note 3 - LD = Laser Discs; DVD = Digital videodiscs; DTV = Digital TV; theaters = Movie theaters; VHS = Videotape format.

Test discs can be purchased from different distributors:

Prologic test CD #SSTCD

- Sony parts distributors. Call 1-800-222-Sony for a distributor

Dolby DVD – TEST 1 # 22707 \$45.

- USC Products Marketing Co.; 1 800 983 6529

DTS Test CD (digital output only)

- Digital Sound Systems Entertainment

5171 Clareton Drive, Agoura Hills, Calif. 91301

1-818-706-3525 part #DTS-CD 96091

- Sony parts distributors. Call 1-800-222-Sony for a distributor
CD part # J2501-154-A \$7.76 list price

DTS Test DVD #DTS-DVD 98061

- Digital Sound Systems Entertainment
Agoura Hills, Calif. 91301
1-818-706-3525 part #DTS- DVD 98061

What is DTS?

Digital Theater Systems has developed a digital audio compression method similar to Dolby Digital AC-3. DTS processed audio is not as compressed as Dolby AC-3. Therefore it is said to have more surround detail (separation), envelopment and better bass because of less compression (losses).

What do I need to play the DTS surround format?

The DTS source can be a DVD movie or CD. The DTS decoder is commonly found in the receiver.

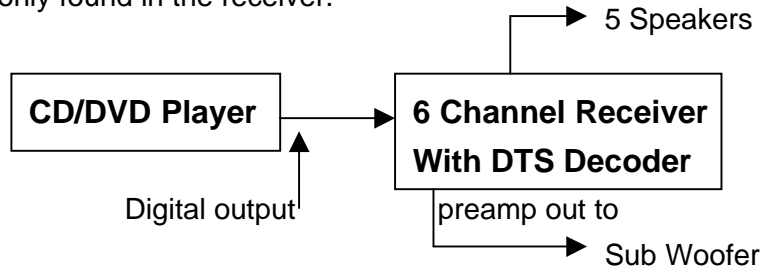

What do I need to play both the AC-3 and DTS surround formats?

The AC-3 source can be DVD or HDTV (future). The decoder can be found in the player or receiver.

AC-3 decoder in the Player:

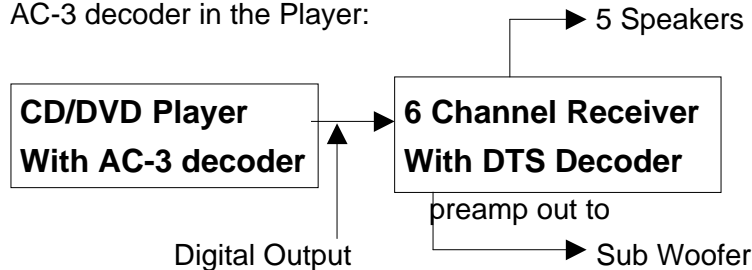

AC-3 decoder in the Receiver:

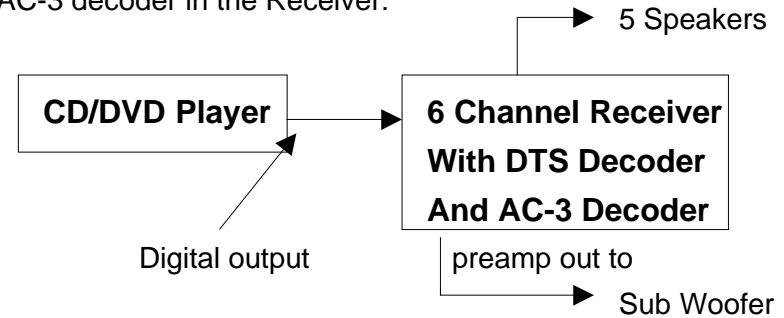

Will a 5.1 channel DTS CD play in my CD player?

Only digital noise will appear from the L/R analog outputs if not automatically muted. There will be digital output from the coaxial and optical ports. Either digital output can be fed to a DTS stand-alone decoder or a receiver with a DTS internal decoder. The DTS receiver will produce the six channels ("5.1") or be downmixed into two (front L/R) channels depending upon the user menu.

A DTS CD compresses the six channels of audio into the space originally occupied by the two-channel uncompressed CD audio. In order for six compressed channels to fit on a CD, the data rate must be equal to or less than the rate of a normal uncompressed CD.

Data rate of an uncompressed CD per channel =

$$16 \text{ bits/sample} \times 44,100 \text{ samples/second} = 706 \text{ Kbytes/sec.}$$

There are two channels so the rate is doubled. Therefore the data rate of a normal stereo CD = 1,412kbit/sec.

This is just about the same data rate as a DTS compressed CD. The DTS data rate is 1,411kbits, so no analog sound will be output from a DTS CD. For comparison, CD, DTS, and AC-3 data rates are shown:

Data Rate Comparison (44.1 kHz sample rate)		
Format		Output Data Rate
CD	Not compressed	1,412 Kbytes/sec.
DTS	Compressed	1,411 Kbytes/sec.
Dolby Digital AC-3	Compressed	384 Kbytes/sec.

Why won't my older DVD player play DTS DVDs?

The DVD DTS flag was not established until Nov 1998. This flag must be inserted into the DVD's digital coax or optical output for the receiver to recognize and decode DTS. Therefore DVD units that are not marked "DTS ready" will not play DTS even though they have digital outputs.

Can DVD movies contain both DTS and AC-3 audio tracks?

Yes they can. Currently the DVD audio choices are:

- PCM – Producing the conventional analog L/R sound
- Dolby Digital or AC-3 – Compressed 5.1 channel surround sound
- DTS – Compressed 5.1 channel surround sound

How does DTS work?

The DTS and AC-3 encoding formats are generally similar. DTS and AC-3 can accept digital (PCM) audio with word lengths from 16 to 24 bits. Both encoders can accept the common 32, 44.1 and 48kHz PCM sampling frequencies, but DTS has 12 more optional frequencies.

The general encoding of the DTS compression system will be explained. DTS has four blocks used to compress the PCM input audio into a single bit stream:

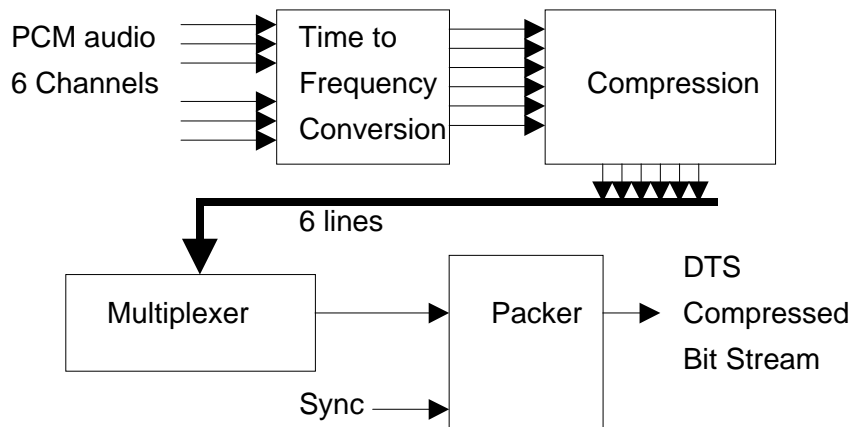

MDCT Time to Frequency Conversion

Each single channel PCM source signal is grouped and allocated to one of 32 frequency bands for analysis. The process is commonly known as Modified Discrete Cosine Transformation (MDCT). This frequency band allocation allows for identification and removal of redundancy among the channels in the next compression stage.

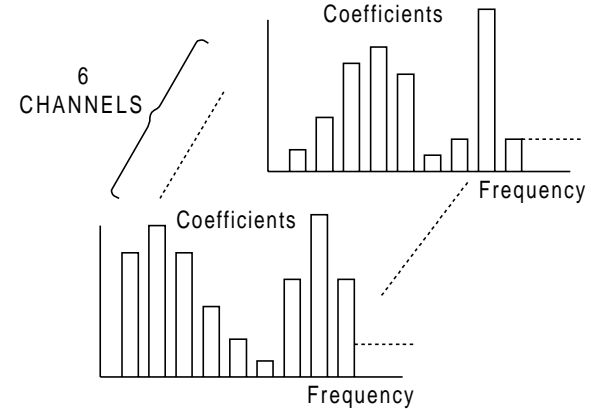

Compression

Adaptive Predictive Coding (ADPCM)

ADPCM involves smaller support stages to:

- Combine the same sounds found in other channels,
- Remove undetectable audio levels (below human hearing thresholds),
- Remove short interval noises that are swamped by louder sounds (psycho acoustic masking); and
- Remove transient noises that do not repeat on the same or other channels.

The support stages include transient, vector and prediction analysis stages to determine if the sound is short term, increasing or decreasing, and if the sound will repeat. Removal or the combination of sounds (compression) is determined by the analysis.

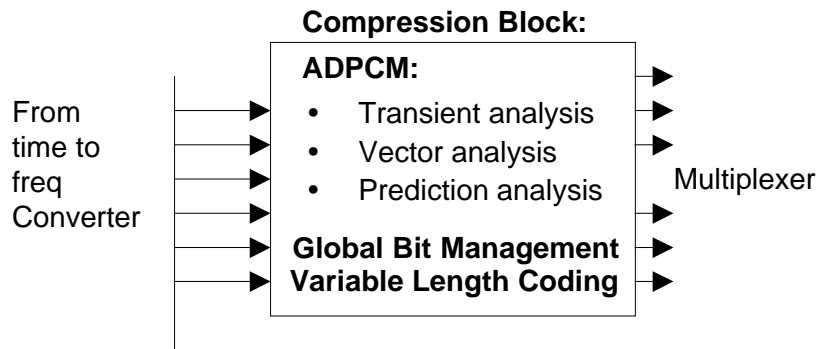

Global Bit Management

Once compression has taken place, an examination of the six data streams for density is made. Bit groups are tagged and moved from a high-density channel to a low-density channel equalizing the amount of data.

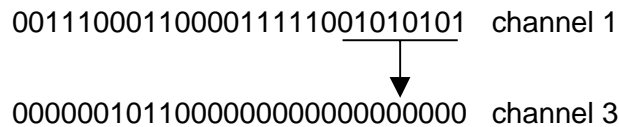

Variable Length Coding

Common fixed length codes and no data (00000000) codes are removed and replaced with shorter codes using a look up table. These shorter length code replacements are flagged for decoding.

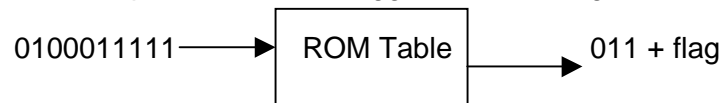

Multiplexer

The six compressed channels are combined into a single line for ease of delivery. To do this each channel is stored into a register made up of flip-flops. A high speed Multiplexer removes the information at six times the storage (sample) speed.

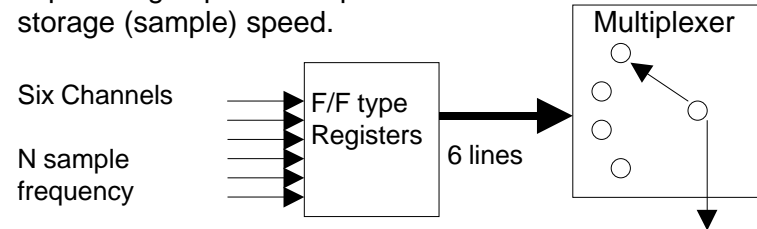

Packer

The packer organizes the information into blocks and adds:

- Error correction
- Synchronization information to each block and groups of blocks

BOARD LAYOUT

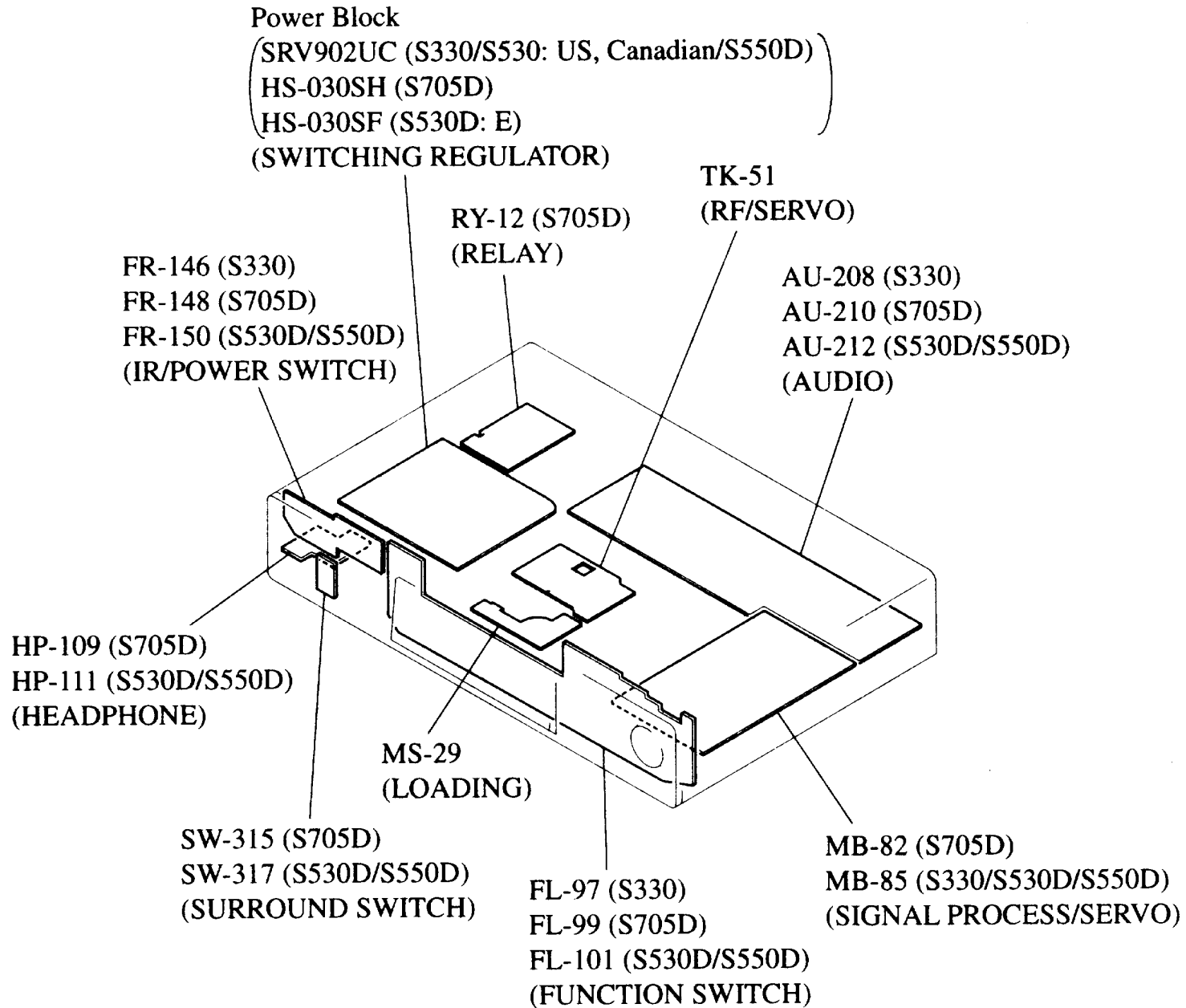

DVD Features

DVD Models	DVP-S330	DVP-S530D	DVP-S550D	DVP-C600	DVP-S7700
MSRP *	\$ 449.00	\$ 499.00	\$ 599.00	\$ 899.00	\$ 1,399.00
General					
Single Optical Assembly	x	x	x		
Dual Optical Assembly				x	x
Active laser platform tilt servo	x	x	x		x
TV / receiver / DVD Remote	x	x	x		x
Advanced Test Mode	x	x	x		x
Glow in the dark Remote keys				x	x
Glass Epoxy Circuit Boards					x
Anti-Resonate Chassis & tray					x
Copper Plated Shielded Chassis					x
Video					
10 bit Video D/A Converter	x	x	x		x
Digital RF Processor	x	x	x		x
Digital Noise Reduction			x		x
Video Page Bookmark			x	x	x
2 Composite Video Outputs	x	x	x	x	x
2 S-Video Outputs	x	x	x	x	x
Component Video (Y, U, V) Outputs		x	x	x	x
Audio					
96kHz / 24 bit audio D/A Converter	x	x	x	x	x
Sony Digital Cinema Sound			x	x	
Virtual Surround Sound		x			
Dolby AC-3 Surround Decoder		x	x		
DTS Decoder					
2 Analog Outputs	x	x	x	x	x
Coax & Optical Digital Outputs	x	x	x	x	x
1/4" Headphone Output		x	x	x	x

* MSRP = Manufacturer's Suggested List Price

Block Diagram

There are four major stages within this DVD player. They operate in this sequence to produce the discs' video and audio:

- Power Supply
- Communications
- Servo Control
- Video and Audio Processing

Power Supply

The power supply block delivers five different voltages. Ever 5V is the only voltage present when the unit is plugged into AC. Ever 5V powers Interface IC201 to switch on the remainder of the voltages when it receives the power ON (P Cont) command.

Communications

Plug In

At plug in, Interface IC201 powers on the unit for 1.3 seconds, keeping the display dark. During this time there is a brief communication between Interface IC201 and System Control IC202 on the serial bus. At the conclusion of this communication "handshaking", the front panel Dolby Digital indicator lights and quickly extinguishes as the unit powers off. The front panel red standby light is on during the entire initial communication, never turning green when momentarily powering up at plug in.

Power ON

At power ON, the red standby light turns to green and the power supply is turned on. After another brief communication between IC201 and IC202, IC202 retrieves and implements the start up program stored in Flash Memory IC205.

The start up program requires IC202 to check for the presence of these six ICs on the parallel bus and IC501 on the serial bus:

ICs Checked During Start Up		
Name	Number	Purpose
1. Flash ROM	IC205	Start up program instructions
2. Hybrid Gate Array	IC601	Expansion port for System Control IC202 to indirectly communicate with others on the parallel bus.
3. SRAM	IC204	IC202's local memory
4. AV Decoder	IC401	Audio (AC-3) and Video (MPEG 2) decoder
5. ARP2	IC303	CD/DVD data processing and separation
6. Servo	IC701	Analog servo control
7. Audio DSP	IC501	Dolby Prologic, Rear channel delays, 5.1 channel downmixing to 2 channels

If an IC does not reply, IC202 instructs IC201 to power off the set.

Servo Control

At the successful conclusion of the start up program, IC202 retrieves servo parameter data from EEPROM IC201 using the serial bus. Then IC202 communicates with expansion port HGA IC601. IC601 relays the information to other ICs connected to it. One of those ICs is IC701. Servo IC701 is instructed to reset the base unit mechanism to the initial position and confirm it:

- Tray closed
- Tilt servo at mid position
- Sled returned to home position

If the initial position is not confirmed before a time limit ("time out"), IC202 will power off the set. Confirmation comes from IC701 through IC601 to IC202.

IC202 then sends commands back to servo IC701 for disc detection.

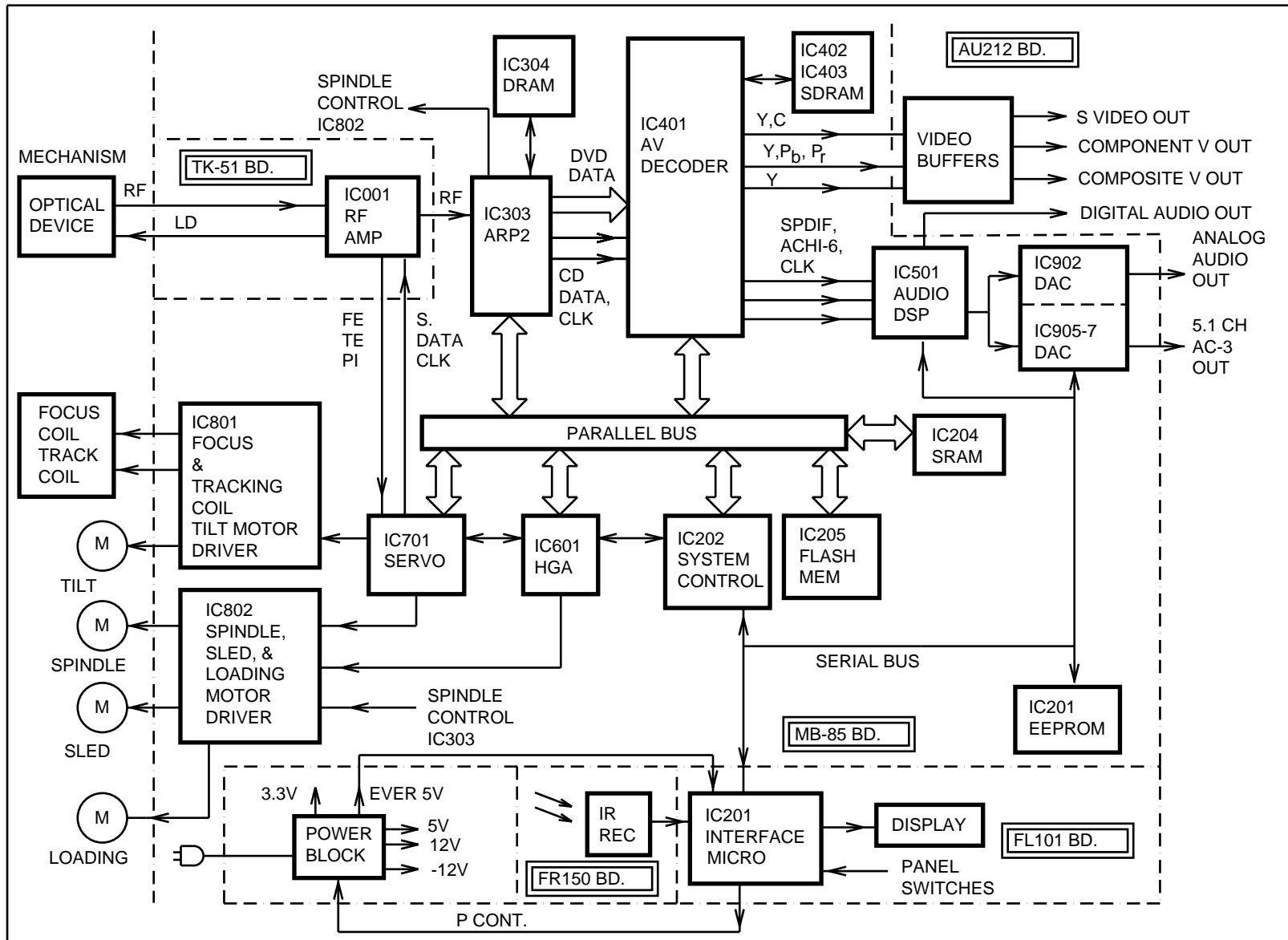

BLOCK DIAGRAM

Video and Audio Processing

After the servos have begun, RF data will come from the optical assembly within the base unit. The “eye pattern” RF data is split into two paths to provide:

1. Feedback signal to lock the servos; and
2. Video and audio information.

In the A/V processing chain, the RF data is processed by the following ICs:

Audio / Video Processing ICs			
Name	IC	Audio or Video	Purpose
RF Amp	IC001	A/V (both)	Matrix the optical outputs to produce signals for servo and A/V circuits
ARP2	IC303	A/V (both)	<ul style="list-style-type: none"> • 16 to 8 bit Demodulation • Descrambles the main data using external memory IC304 • Generates bit clock
Decoder	IC401	A/V (both)	<p style="text-align: center;"><u>Video</u></p> <ul style="list-style-type: none"> • MPEG decompression using the external IC402 and IC403 memories • Crops the 16x9 image for a 4x3 TV picture • Controls spindle motor speed • Sends disc's control and menu data to IC202 • On screen display graphics • D/A Converter (analog video output) <p style="text-align: center;"><u>Audio</u></p> <ul style="list-style-type: none"> • MPEG audio decompression • Dolby Digital AC-3 decompression using external SRAM IC402 / IC403
DSP	IC501	A	<ul style="list-style-type: none"> • Sound enhancements when there is no AC-3 received (Rear channel delay) • Downmixing of 6 channel AC-3 into 2 (L/R) channels • Dolby Prologic decoding • Digital coax and optical output • Rear channel delay • Front/rear level balancing • Test tone generation
DAC	IC902	A	Digital to analog converter for the front left and right channels
DACs	IC905-IC907	A	3 Digital to analog converters for the six AC-3 channels

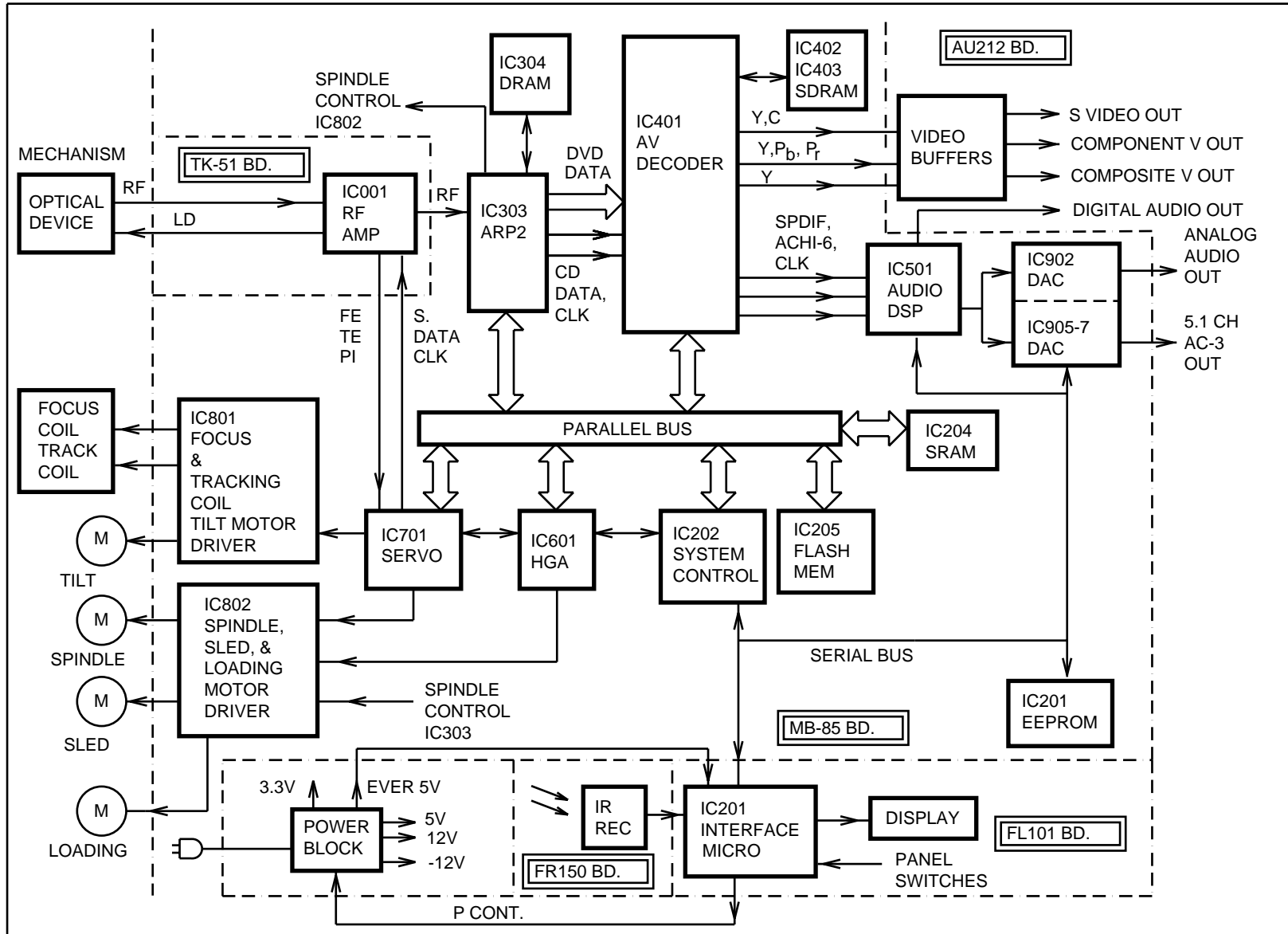

BLOCK DIAGRAM

1DVD02 1146 6 22 99

Power Supply Block

The power supply is on a single board located to the left of the DVD mechanism. This board contains both the standby and the main power supply. The input line filter L101 and the board connectors are the only parts that are not available.

Standby Power Supply

This power supply produces Ever 5V as long as AC is present. Ever 5V is supplied to interface IC201 (MB85 board) and the mute transistors (AU212 board). The standby power supply consists of an oscillator and an error regulator. The oscillator consists of switch Q121 and a control transistor Q122. The oscillator output is applied to T102. T102's secondary is rectified to output Ever 5V.

Regulation

The Ever 5V voltage regulation circuit uses:

- IC202 – error detector
- PC121 – photocoupler
- Q122 – control transistor.

IC202 samples the Ever 5V output and produces a correction voltage. Photocoupler PC121 passes the error voltage from the cold ground circuit to the hot ground side circuit. The control transistor Q122 receives the error voltage and uses it to alter the base bias of switch Q121. The change in bias alters the off time of the oscillator signal. This changes the oscillator frequency. The changes in frequency affect the efficiency of the transformer, which regulates the Ever 5V.

Main Power Supply

The main power supply works similarly to the standby supply except the main supply is switched, handles more power and has multiple secondaries.

The main power supply is switched ON by PCONT from the Interface IC on the FR148 board. A high at PCONT enables switch Q101 to begin oscillating. Transformer T101 produces several output voltages that are rectified into DC for the remainder of the DVD unit.

When a shorted spindle motor driver IC802 loaded the unfused +12V supply line, the main oscillator quit. The oscillator worked again when the short was removed.

Regulation

The 3.3Vdc output is used to regulate the main power supply. Error detector IC201 receives the 3.3Vdc and produces a correction voltage. If the input voltage increases, the error detector output decreases. The PC101 photocoupler passes the correction signal to the control transistor Q102. Q102 adjusts the off time of the oscillator signal to correct the 3.3Vdc output the secondary. If the DVD power consumption is normal, the remainder of the T101 outputs will be correct.

Power Consumption

The current along each supply line was measured in both the idle and the DVD disc playback mode.

Model DVP-S530D Current Consumption			
Supply line	Part replaced by Ammeter	Current	
		Idle	Disc PB
Ever 5V	L205	30ma (set off)	77mA (set on)
+12V partial	PS201	196mA	198mA
+12V total	L201	236mA	350-700mA
+5V	PS202	281mA	305mA
+3.3V	PS203 *	894mA	950mA
-12V	PS204	129mA	130mA

* Use short ammeter leads or the unit will not PB the disc and the display will not come on. The PS203 current without the display will only be 580mA.

Oscillator Frequencies

Power Supply Oscillator Frequencies		
Power Supply	Set Off	Set On (stop mode)
Standby (Q121/D)	57.45kHz	49.65kHz
Main (Q101/C)	0	101.2kHz

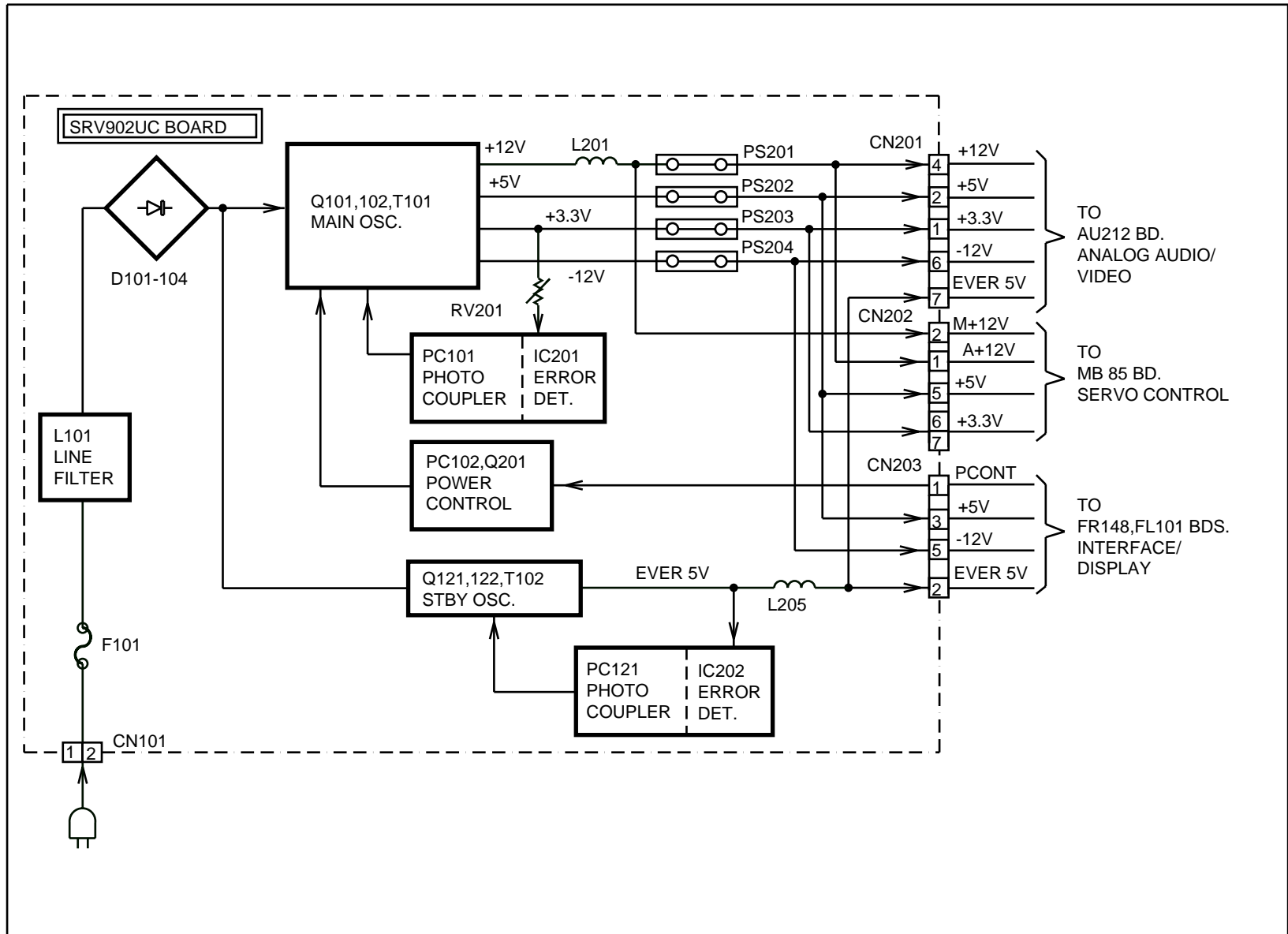

POWER SUPPLY BLOCK

2DVD02 1137 4 27 99

Standby Oscillator

The standby oscillator produces Ever +5 volts when the DVD player is plugged into 120VAC. This Ever 5V is applied to the Interface IC201 (on the circuit board behind the front panel) and the audio and video mute transistors (on the rear board). The standby oscillator stage consists of two transistors and a transformer. Regulation is performed using the Ever 5V output to control the off time of the oscillator cycle.

The standby oscillator has three operational parts:

- Start
- Run
- Regulation

Start

At AC plug in, the standby oscillator stage begins when R122 and R123 bring the FET Q121 gate voltage from 0 to about 1volt. This turns on the low power FET, allowing it to pass Drain to Source current and complete T102's primary circuit path to hot ground.

Run

Oscillator transistor Q121 turns ON

As current flows in T102's upper left primary winding, a voltage is induced in the lower secondary winding that will keep FET oscillator Q121 turned ON. A positive voltage from the lower secondary winding takes two paths. The first path is through R126, R125 and C121 to Q121's gate. This keeps Q121 conducting. The second path is through R127 and R128 to Q122's base. Q122's collector is connected to the oscillator's gate. As a result, Q122 becomes an active resistor. Q122's conduction prevents the gate voltage from rising too high (protection) and later we will see that it is used for regulation.

Oscillator transistor Q101 turns OFF

When Q101 is saturated, there is no longer a change in T102's primary current. The voltage induced into the lower secondary winding decays. This reduction in bias voltage permits Q121 to turn OFF. With Q121 OFF, the magnetic field in T102's primary winding collapses, causing current flow through C123 and limiter R130.

The collapsing magnetic field induces a negative voltage into the lower secondary winding. The negative voltage takes two paths to reset the oscillator. The first path is through R126, R125 and C121 to keep oscillator transistor Q121 OFF. The second path is through D121 and R128 into the base of Q122. This turns off transistor Q122 in preparation for the next oscillator cycle.

Regulation Concept

Regulation of the Ever 5V line is accomplished by sampling the output voltage and using it to reduce the off time of the oscillator. By reducing the off time, the total oscillator cycle is reduced. Shortening the time it takes to complete a cycle means its frequency is increased.

This oscillator signal is applied to transformer T102. A transformer has an optimum frequency that will allow maximum power transfer (at resonance). When the applied oscillator frequency is above resonance, the efficiency drops and its secondary voltage is reduced. By varying the applied frequency, the output voltage can be regulated.

Regulation Circuitry

IC202 is the error regulator for this stage. Voltage divider R212, R209 and R210 reduce the Ever 5V so there is 2.5V at IC202's input. This allows its operation in the linear region. IC202's output (collector) is inversely proportional to its input. The collector output is connected to the opto-isolator diode that passes the error signal to the hot ground oscillator circuit.

If the Ever 5V increased, the opto-isolator transistor would conduct more, reducing the resistance between the lower secondary winding and Q122's base. The reduced resistance allows more current to flow, permitting Q122 to turn on sooner. The sooner it turns on, the sooner the FET turns off, increasing its frequency of operation that results in a reduced output voltage for regulation.

IMPORTANT VOLTAGES MEASURED WITH THE SET OFF:

	Voltage	DC Voltage
Q101/Drain	300Vp-p	166V
Q101/Gate	13.8Vp-p	2V
D121/Anode	16Vp-p	0V

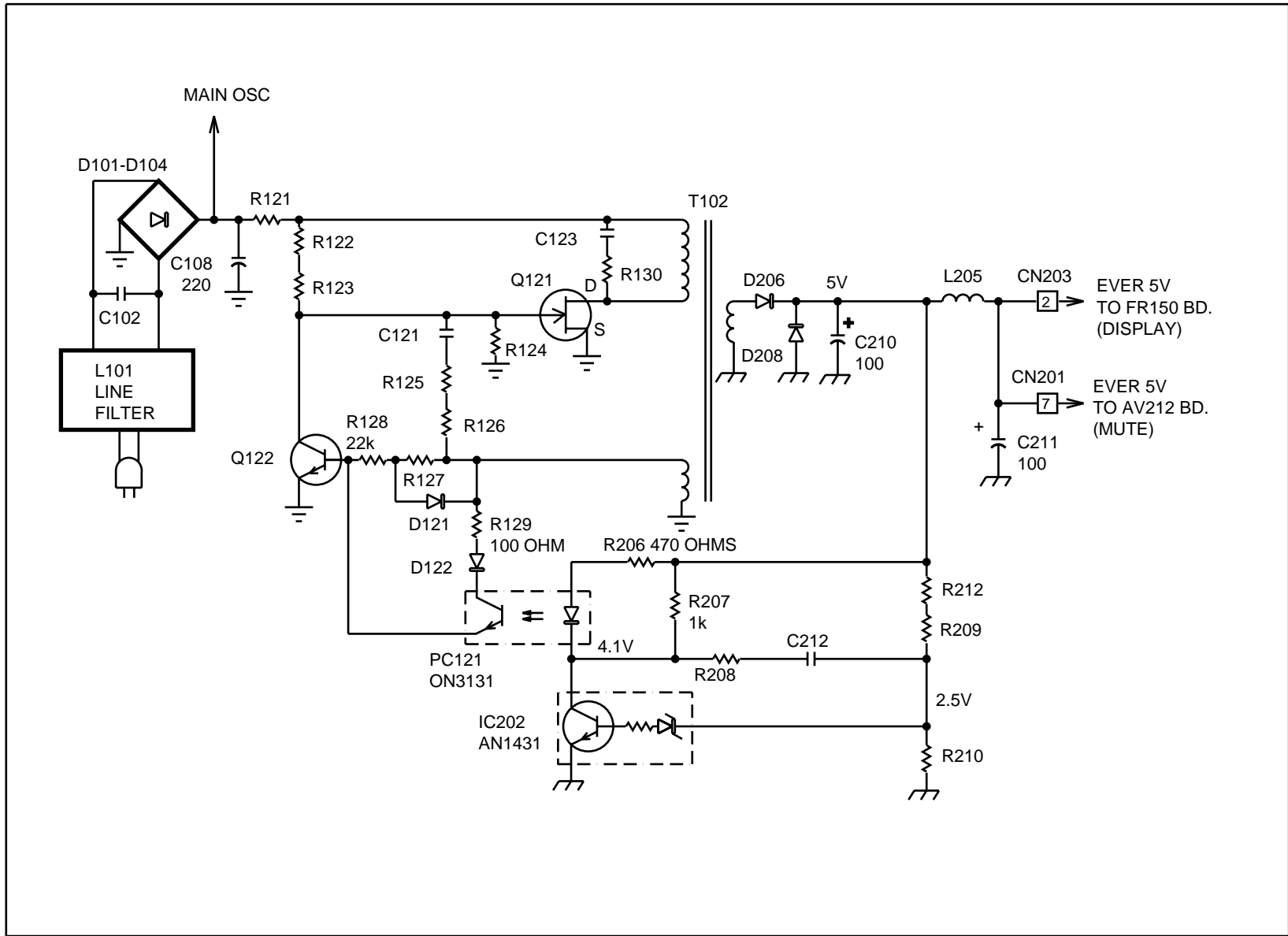

STANDBY OSCILLATOR

29DVD02 1175 6 28 99

Main Oscillator

The main oscillator stage operates like the standby oscillator stage except that the main oscillator is switched ON/OFF and there are multiple secondaries to supply the needs of the DVD player.

The main oscillator has four parts:

- Enable
- Start
- Run
- Regulation

Enable

Oscillator OFF

The operation of the main oscillator is inhibited by PC102. When the unit is plugged into AC, Ever 5V is made by the standby oscillator stage and is used to turn on the opto-isolator LED in PC102. The LED's infrared light turns on the phototransistor and it conducts.

PC102's phototransistor is connected to oscillator transistor Q101's start voltage applied to the base. When PC201 conducts, the start voltage from R102/R103 is grounded, stopping the oscillator.

Oscillator ON

Q201 removes the voltage to the opto-isolator diode in PC102, permitting the main oscillator stage to run. When PCONT from Interface IC201 goes high at CN203/pin 1, Q201 turns ON. Its conduction grounds the voltage from R211, removing voltage from the LED. PC102 transistor turns off, removing the ground from R103 so the main oscillator transistor Q101 can start.

Start

Once the PCONT control line at CN203/pin 1 goes high, PC102's transistor no longer conducts. The ground is removed from the start voltage at the junction of C111 and R104 so it rises. It will reach 6.6V, limited by the voltage divider formed by R102, R103 and R104.

Sufficient current passes through C111 during this voltage increase to turn ON main oscillator Q101. This is how oscillator transistor Q101 starts conducting (turns ON) and the main oscillator starts.

Run

Q101 Turns ON

When Q101 turns ON, current flows through the main transformer's primary winding at the upper left of T101. This induces a positive voltage to the lower T101 winding that follows two paths. The first path is through R106, R107, D109 and C113 to Q101's base to keep it conducting. The second path is through D108 and R109 to bias Q102. Q102 acts like an active resistor at Q101's base to keep the voltage from becoming excessive (protection) and is used later for regulation. Consequently the correct value components and transistors are critical.

When Q101 reaches saturation, there is no longer a change in T101's primary current. The steady current flow no longer induces a voltage into the lower secondary winding and the secondary voltage decays.

Q101 Turns OFF

The reduction in secondary voltage turns Q101's OFF. The magnetic field in T101's primary collapses. D105, limiter, L102 and C110 short its energy. D106 is used to discharge C110 (when Q101 is ON).

The collapsing (changing) magnetic field induces a negative voltage at the lower secondary winding. This negative voltage from T101 passes through R106, R107 and C113 to the base of oscillator transistor Q101. It is used to cut off Q101 to conclude this oscillator cycle.

Regulation

The 3.3-volt output is monitored by error regulator IC201 and used to control the conduction of phototransistor PC101. If the 3.3-volt line rises, the phototransistor conducts harder. This reduces the resistance between the lower secondary winding and Q102's base, increasing Q102 base current.

The increased base current drives Q102 harder, lowering the oscillator's base bias voltage and causing the oscillator to be turned OFF sooner. When part of the oscillator waveform is shortened, its frequency increases. This reduces T101 efficiency and the 3.3V output voltage is returned to normal.

IMPORTANT VOLTAGES:

Q101/Collector = 336Vp-p; 150Vdc.

PC101/collector = 2.6Vdc. PC101/emitter = 0.21Vdc

Feedback secondary voltage at D108/cathode = 20Vp-p; 0.21Vdc.

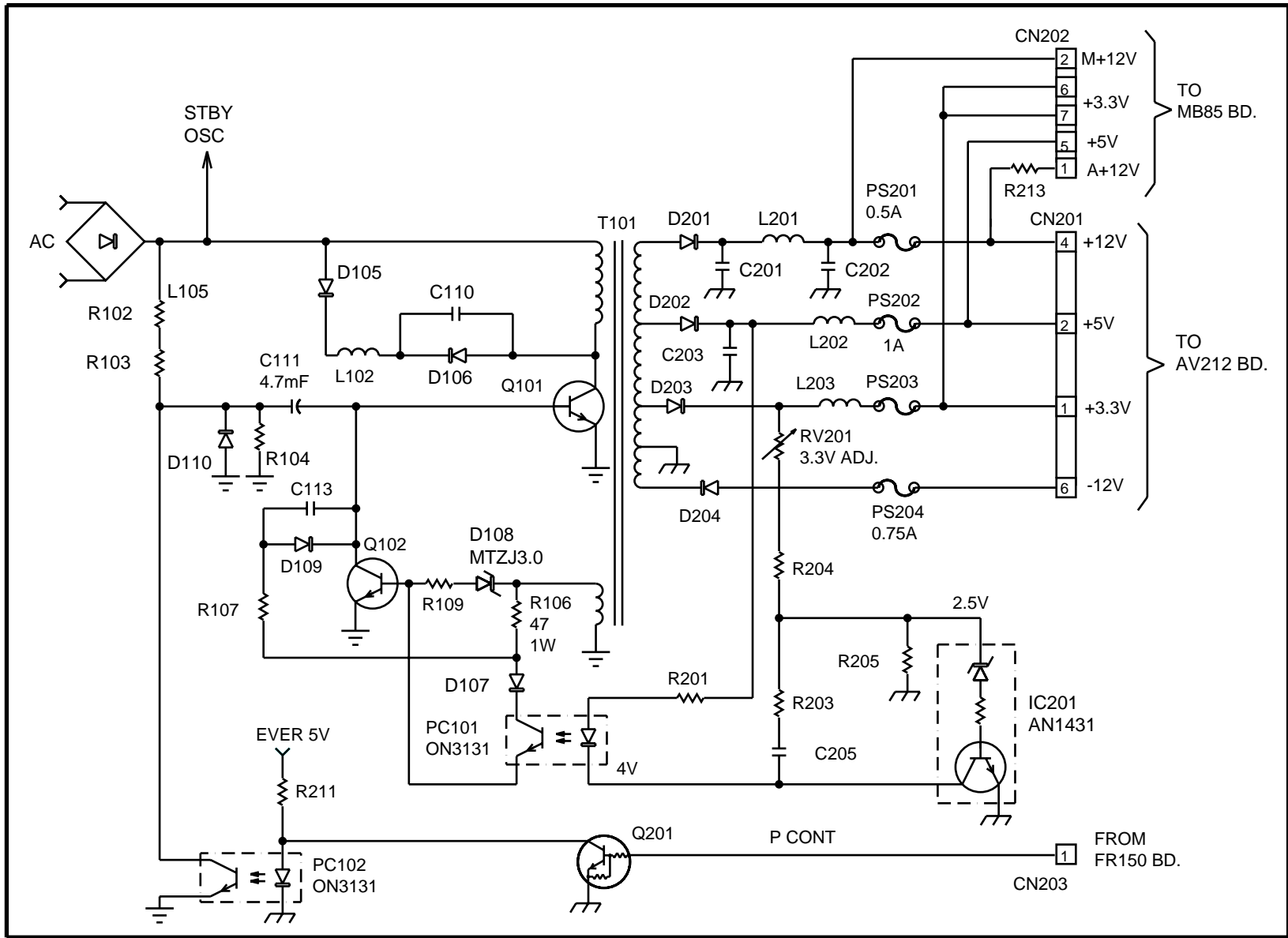

MAIN OSCILLATOR

30DVD02 1174 7 12 99

Power Control

Plug In

When the DVD player is plugged into AC, the power supply only outputs Ever 5V to:

- Analog audio mute transistors – AU-212 board
- Interface IC201/pin 16 – FL101 board
- Reset IC202/pin 5 - FL101 board

The mute transistors are biased ON to keep the 5.1, headphones and L/R channel audio outputs grounded.

Ever 5V applied to Interface IC201 starts the 4MHz X201 crystal connected to pins 14 and 15.

Reset IC202 on the FL101 board uses C211 to hold its pin 4 momentarily low when Ever 5V is first applied. This resets Interface IC201/pin 18.

After reset, a brief communication occurs between IC201 and IC202. A momentary light of the front panel blue Dolby Digital LED (D203) marks the end of the plug in communications and the unit shuts down.

The plug in sequence is listed below:

1. AC plug in
2. Ever 5V is applied to Interface IC201/pin 16
3. X201 becomes active and stays active
4. Red power off/standby LED comes ON.
5. PCONT from Interface IC201/pin 24 goes high to power the set
6. Ready pulse is output IC201/pin 78 as an interrupt line to IC202 to begin communications. It is difficult to see this low going interrupt pulse on a scope, but it will light a scope's "triggered" LED.
7. IC601 transfers this "ready" (interrupt) information to System Control IC202 by using another interrupt signal from IC601/pin 155 (low going). The low forces IC202 to generate a chip select (CS1 or CS4) so the data can be transferred to IC202 on the parallel bus.
8. System Control IC202 sends chip select (difficult to see the low going pulse from pin 97), bit clock (low pulses from pin 78) and serial data (high pulses from pin 77) to Interface IC201.
9. IC201 acknowledges by lighting the Digital Dolby LED D203

10. Interface IC201 brings PCONT low, removing power to the set. Unit is now in standby and ready to be powered ON.

IC201 – IC202 Communications Waveforms

The following sets of waveforms show this communication between IC201 and IC202. Notice that the Dolby Digital LED is turned ON only at the conclusion of the plug in communications. The LED does not light when there are incomplete communications.

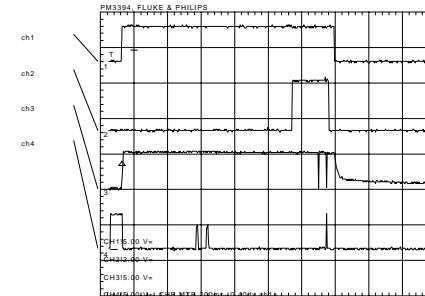

Plug in Communications – between IC201 / IC202			
Channel	Name	Location	Voltage/div
Channel 1	PCONT	CN203/pin 1	5Vp-p
Channel 2	Dolby Digital LED	D203/anode	2Vp-p
Channel 3	CS from IC202	CN006/pin 3	5Vp-p
Channel 4	Data from IC201	CN006/pin 4	5Vp-p
Time base	200msec/div.		

The following second set of waveforms is taken of IC202 CS signal (ch 3) that is replying to IC201. Notice that the return clock (ch 3) and data (ch 4) from IC202 occur before IC201 turns the LED (ch 2) ON.

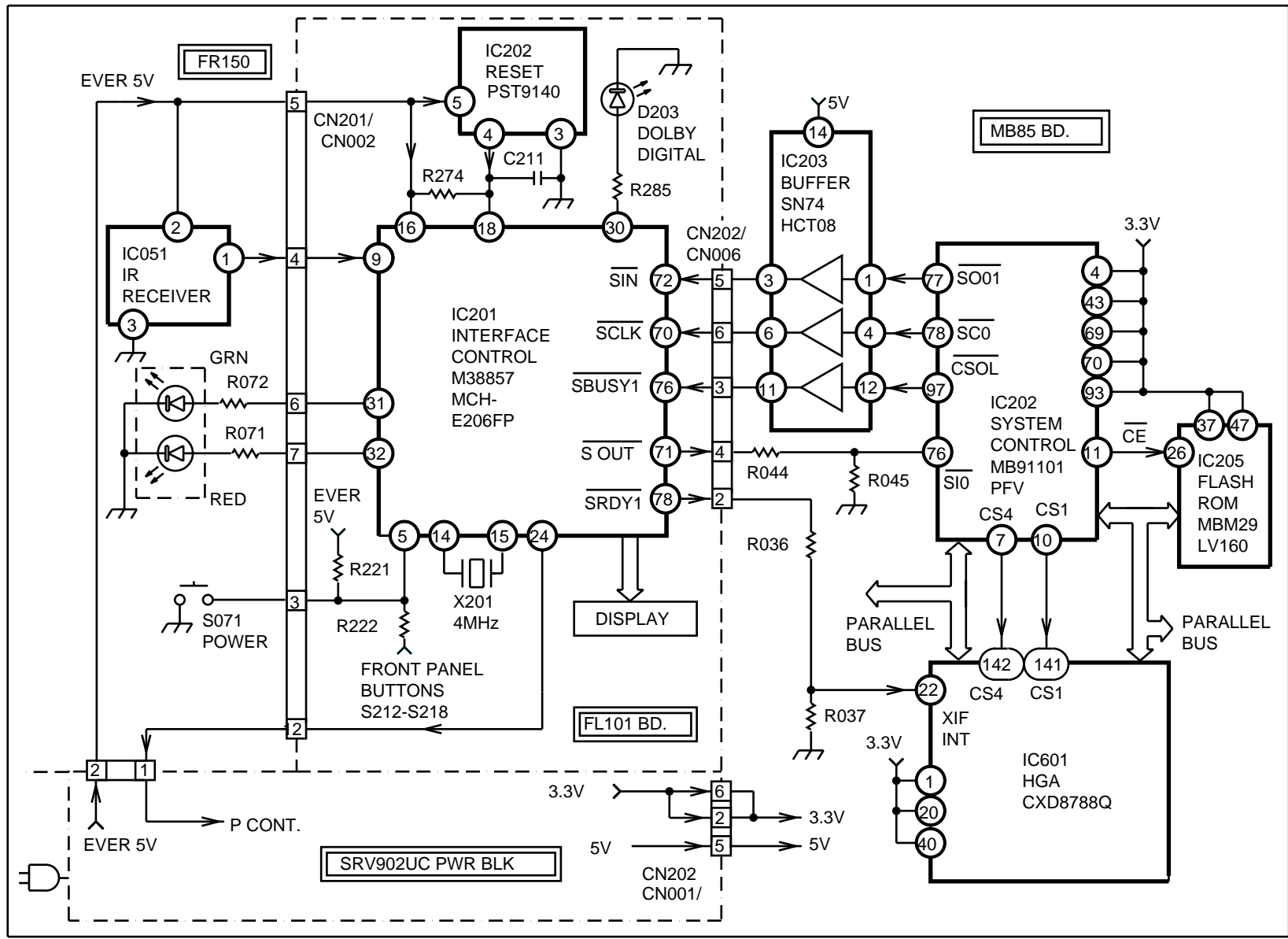

POWER CONTROL

13DVD02 1154

6 22 99

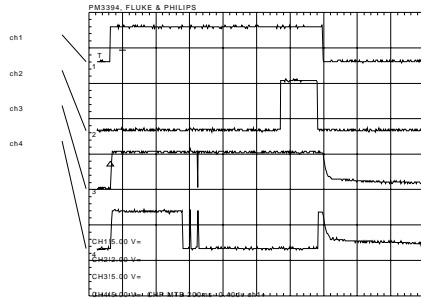

Plug in Communications – between IC201 / IC202			
	Name	Location	Voltage/div
Channel 1	PCONT	CN203/pin 1	5Vp-p
Channel 2	Dolby Digital LED	D203/anode	2Vp-p
Channel 3	Bit clock from IC202	CN006/pin 6	5Vp-p
Channel 4	Data from IC202	CN006/pin 5	5Vp-p
Time base	200msec/div.		

Power ON

IC201

The power ON operation works much like a modern day computer. When the power ON command is received, Interface IC201 begins a boot up sequence using IC202 and IC205 to finish it. IC201 causes:

- The red standby light to turn to green;
- PCONT (at IC201/pin 24) to go high, powering the set; and
- Communications with System Control IC202, continuing the power ON operation

IC202

IC202 continues the power ON operation, retrieving start up information from the Flash ROM IC205. This start up information instructs IC202 to check each IC on the parallel bus and wait for an acknowledgement signal. At power ON, these ICs are polled in the order shown in the table:

Power ON IC check sequence (not shown in the diagram)	
Chip Select Source	Destination IC
1. CS 1 - IC202/pin 10	SRAM IC204 / HGA IC601
2. CE – IC202/pin 11	Flash ROM IC205
3. CS 3 – IC202/pin 8	AV Decoder IC401
4. CS 4 – IC202/pin 7	HGA IC601
5. CS 2 – IC202/pin 9	AV Decoder IC401
6. XCS – IC601/pin 111	ARP2 IC303
7. HCS - IC601/pin 118	Servo IC701

When all the replies have been received, Interface IC201 is informed and IC201 keeps the unit powered ON (PCONT remains high). At the same time, IC201 turns on the front panel blue Dolby Digital LED.

If a communications failure occurs and there is no acknowledgement signal to IC202 within three seconds of power ON, the unit will turn off. The PCONT signal (from IC201/pin 24) will go low and the player power is removed. The green power ON light changes back to red (standby mode).

Post Power ON Check

Therefore, if the blue Dolby Digital LED lights, communications have taken place and the unit remains ON. The next step is to determine if there is a disc present. The disc check sequence is:

1. Tray up and chucked – chuck switch feedback
2. Sled moves to home position – photosensor feedback
3. Sled moves outward – no feedback (stepping motor)
4. Laser is turned ON momentarily while focus searching
5. Focus Search is performed – FE and PI feedback signal
6. Sled moves outward further – no feedback
7. Laser is turned ON and Search is performed again
8. Sled moves outward further – no feedback
9. Laser is turned ON and Search is performed a third time
10. Sled moves inward to home – photosensor feedback
11. Laser is turned ON and Search is performed a fourth time
12. Spindle motor rotates – FG amp kick drive feedback
13. Display reads NO DISC.

If an IC fails to receive the correct feedback from its sensors, System Control will instruct IC201 to enter standby (red front panel light).

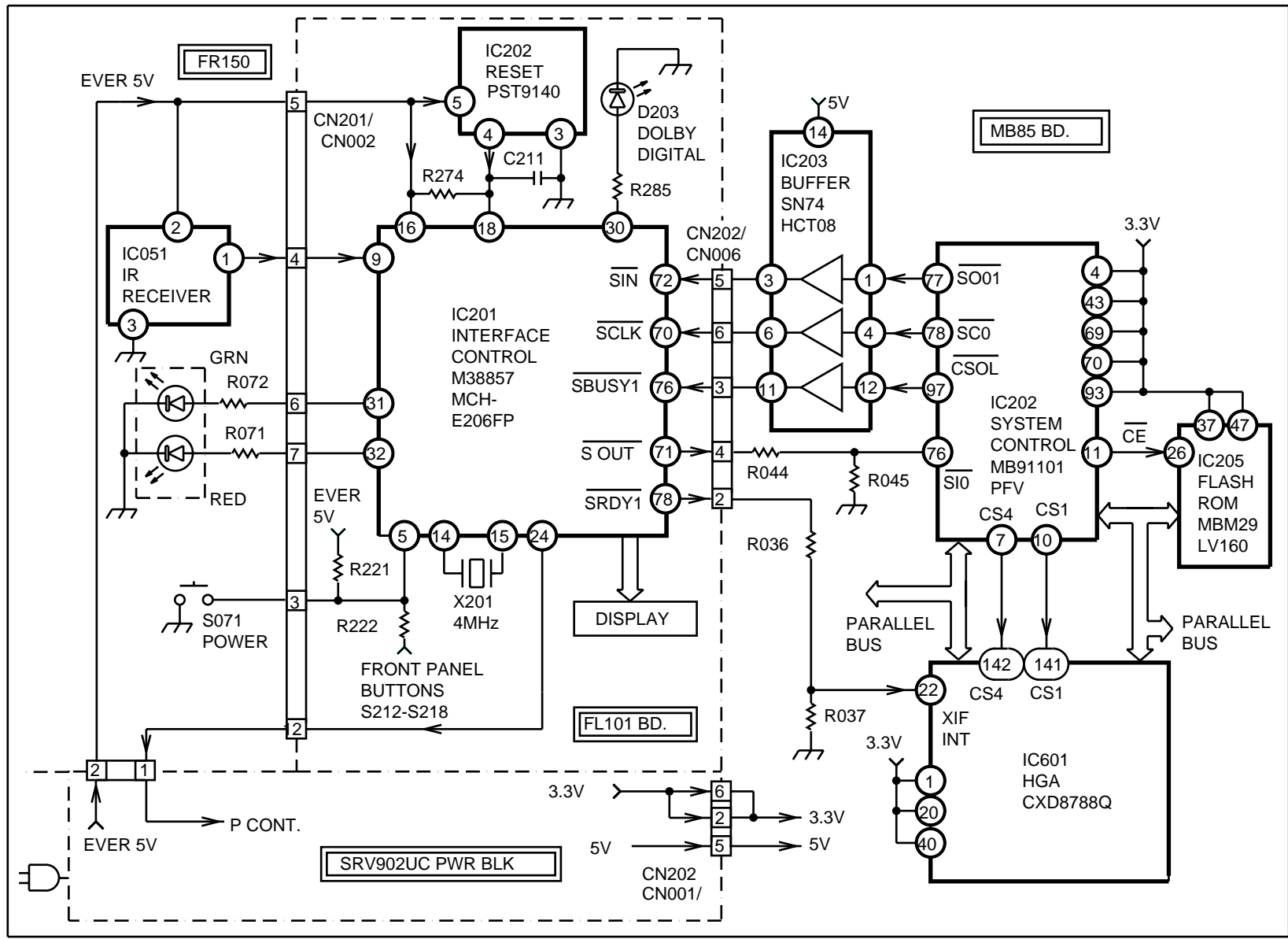

POWER CONTROL

13DVD02 1154

6 22 99

Communications Block

Both serial and parallel bus structures are used in the same unit of today's DVD players. The serial data bus is a simple way to provide communications between ICs. On one line, data is transmitted one bit after another to the next IC in 8, 16, 20, 24 or 32 bit groups. On another line, corresponding clock pulses accompany the bits of data. One clock pulse identifies each bit of data - this is why this line is also called a bit clock. Therefore, it takes 8, 16, 20, 24 or 32 clock pulses to receive a group of data in a serial bus.

A parallel data bus is used when large amounts of data need to be transmitted in a shorter time frame. In the parallel bus, multiple data lines are used along with a clock line. When a single clock pulse is sent, the 8, 16, 20, 24 or 32 lines each simultaneously transmit a bit of data to the receiving IC. (Only 16 data lines are used here.) Therefore, it takes only one clock pulse to receive a group of data in a parallel bus.

The parallel bus is used in processing video information (IC401) and in the disc playback servo (IC701) where large amounts of data must be handled quickly.

Serial Data

The serial data bus connects several ICs and consists of two or three lines. Serial data is transmitted from one IC to another on a unidirectional line (arrows shown in one direction). This data is accompanied by a clock signal for a total of two lines in a unidirectional serial communication.

The interface control IC201 and System Control IC202 communicate bidirectionally (arrows shown in two directions). Three lines are necessary when bi-directional transmissions are called. There is a data line for each direction. The additional clock signal makes a total of three lines for a bi-directional serial bus. The clock signal usually comes from the controlling micro, which in this case is System Control IC202.

System Control IC202 communications with Interface IC201, EEPROM IC201 and DSP IC501 are bi-directional. System Control communications to the Digital to Analog Converters (DAC) IC902, IC905-7 are unidirectional.

Parallel Data

The parallel data bus is much more complicated than the serial bus. It consists of address lines, data lines and a clock line. Just before data is transmitted from one IC to another, a location is designated using address lines. Then clock pulses are sent from the master IC202 to transfer the data into the receiving IC.

When communications are bi-directional on the parallel bus, an additional line identified as write enable (WE) and/or read enable (RE) is used. These lines determine the direction of the data to or from the master IC. When there is no WE or RE line, the bi-directional data communication is pre-established first as read-data from the master micro. Write-data occurs afterwards.

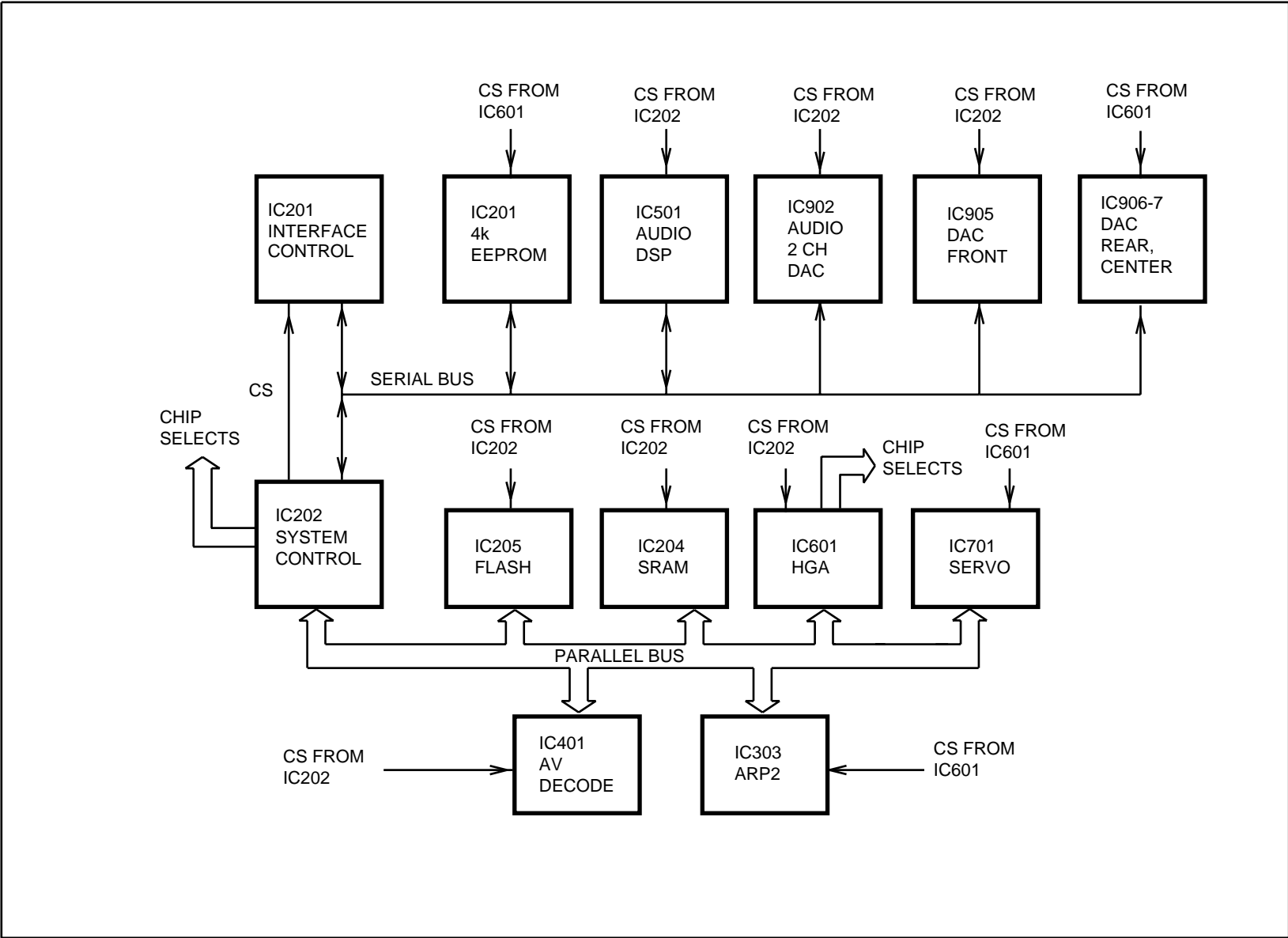

COMMUNICATIONS BLOCK

Serial Data Communications

A close examination of the serial bus structure shows there are two serial buses. Both are active as long as the set is ON.

Serial Bus 0

Serial Bus 1

Serial Bus 0

Bus 0 is used for bi-directional communications between:

- System Control IC202
- Interface IC201
- EEPROM IC201

System Control IC202 is the master IC. It sends and receives data on the serial data in (SI0, at IC202/pin 76) and out (SO0, at IC202/pin 77) lines. The data is always accompanied by serial clock (SC0, at IC202/pin 78) from IC202. There are always communications between these two ICs as long as there is power applied.

Interface IC201

System Control IC202 has the continuous task of transferring display information to the Interface IC201. The Interface IC201 must inform System Control IC202 that there is a new command such as play or stop.

Communications begin when Interface IC201/pin 78 outputs a low going “ready” pulse. In this IC the ready command is more like an interrupt command. This low going pulse is received by IC601/pin 22, which is used as an expansion port to access System Control IC201 via the parallel bus. The interrupt input is periodically checked within IC202’s program. When found, IC202 will enter a subroutine and acknowledge IC201’s request to send data for processing.

System Control IC202 acknowledges the interrupt signal by outputting two signals: a low chip select signal from pin 97 and a clock signal from pin 78. This allows for data communications on the SI0 and SO0 lines at

IC202/pins 76 and 77 to occur. The entire operation is similar to someone working when interrupted by a doorbell. When he is ready, he will answer the door. Afterwards he returns to his work in the house or elsewhere. The IC201 to IC202 communications sequence is:

System Control IC202 and Interface IC201 Data Transfer Sequence		
Name of Signal	Signal Source	Signal purpose
1. SRDY (ready)	IC201/pin 78	Request communications
2. CSOL (chip select)	IC202/pin 97	Communications window (active low)
3. SC0 (clock)	IC202/pin 78	Serial clock for data
4. SI0 (data)	IC201/pin 71	User commands
5. SO0 (data)	IC202/pin 77	Display update
6. CSOL (chip select)	IC202/pin 97	Communications ends (returns high)

EEPROM IC201

During playback or when playback is started, System Control IC202 retrieves information held in EEPROM IC201. IC201 holds servo data and stores some disc parameters, such as how many information layers are on the disc. Some of this data is visible in the test mode.

Bi-directional communications between System Control IC202 and EEPROM IC201 is accomplished using:

- Two single direction serial data lines (SO0 and SI0)
- Clock pulses from IC202/pin 78
- Chip Select signal from IC601/pin 23

Periodically in IC202’s routine, EEPROM IC201 is chip selected (when pin 3 is brought low). When this occurs, data is transferred between the ICs on the data lines (SO0 and SI0).

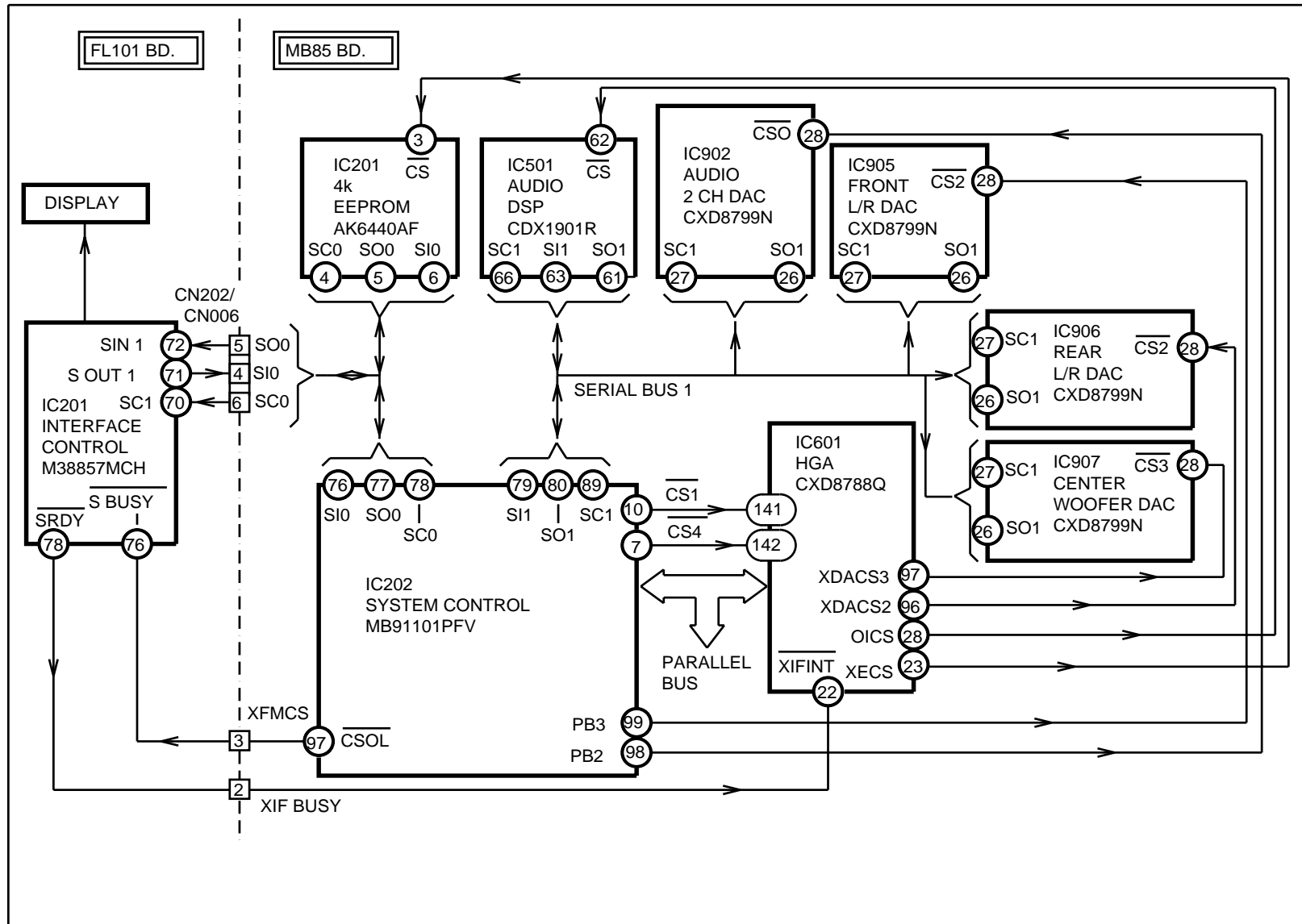

SERIAL DATA COMMUNICATIONS

Serial Bus 1

Bus 1 is used for communications between:

- System Control IC202
- Audio DSP IC501
- Audio 2 channel IC902
- Front, Rear, and Center D/A converters IC905 to IC907

System Control IC202 is the master IC. It sends and receives data on the serial data in (SI1, at IC202/pin 79) and out (SO1, at IC202/pin 80) lines. The data is always accompanied by serial clock (SC1, at IC202/pin 89) from IC202. There are always communications present at IC202/pins 79,80 and 89 as long as there is power applied just like in serial bus 0.

Audio DSP IC501

Bi-directional communications between System Control IC202 and IC501 is similar to that with EEPROM IC201. Communications between System Control IC202 and Audio DSP IC501 are accomplished using:

- Two serial data lines (SO1 and SI1)
- Clock from IC202/pin 89
- Chip Select from IC601/pin 28

Periodically in IC202's routine, Audio DSP IC501 is chip selected. When the chip select pin 62 line is brought low, data is transferred between the ICs on the data lines (SO1 and SI1).

Audio 2 Channel D/A Converter IC902

Audio Front, Rear, and Center D/A Converters IC905 - IC907

System Control IC202 communicates with the remainder of the ICs on the serial bus 1 lines in a unidirectional manner. Each one of these D/A Converters has an individual chip select line from IC601. The SO1 data line from IC202/pin 80 is common to the D/A Converters. Data applies only to the D/A Converter when its chip line is low. The data as always is accompanied by bit clock from IC202/pin 89.

IC Function		
IC Name	Number	Function
System Control	IC202	Main Micro
Interface	IC201-FL101 Bd	Accepts user commands (play, open tray, next, etc)
EEProm	IC201-MB85 Bd	Stores servo info
Audio DSP	IC501	Delays (echoes) for speaker effects
Audio 2 channel D/A Converter	IC902	D/A Converter for analog audio
Front, Rear, Center, D/A Converter	IC905 - IC907	D/A Converter for 5.1 AC-3 signal.

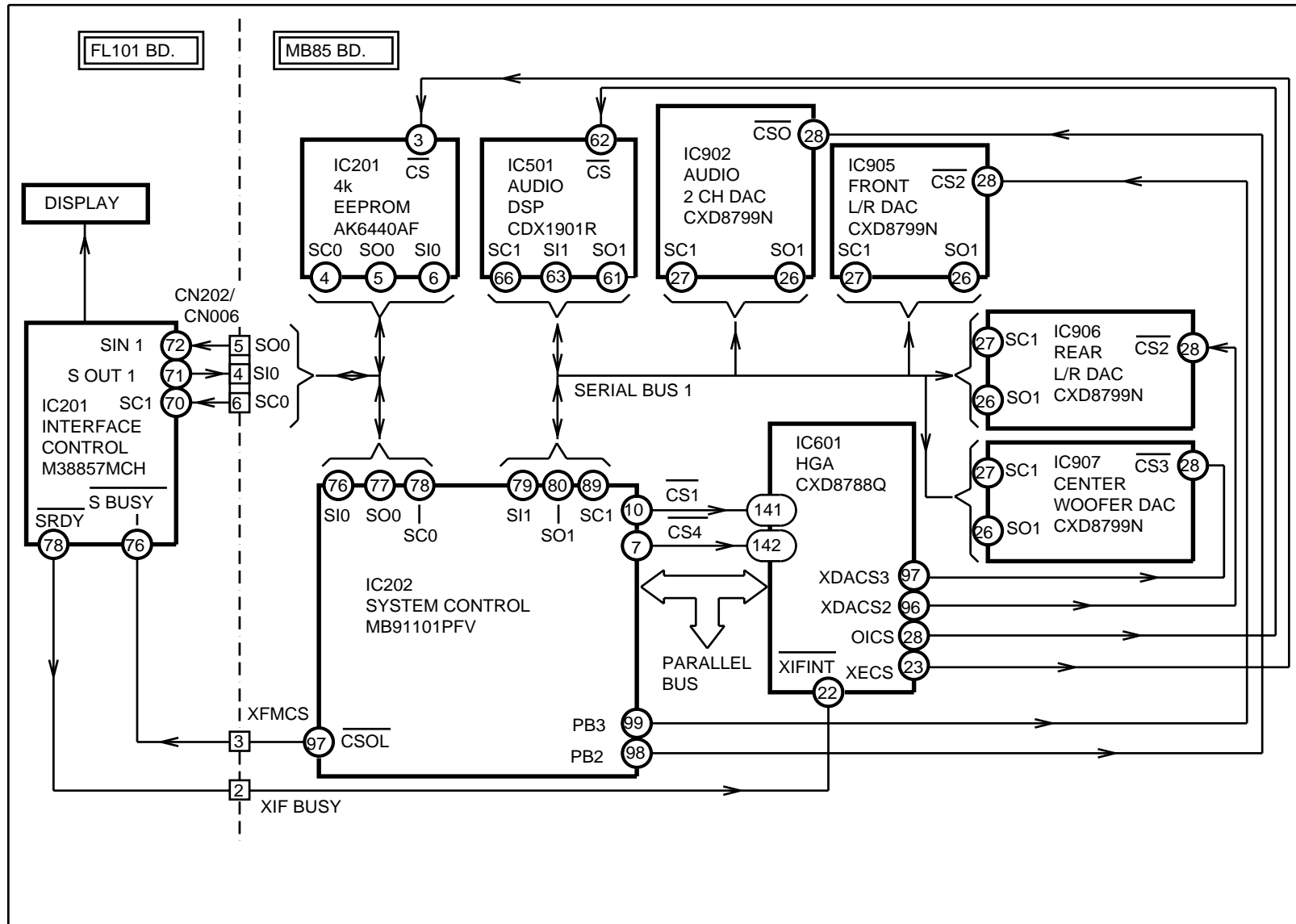

SERIAL DATA COMMUNICATIONS

Parallel Data Communications

There are six ICs that communicate with System Control IC202 on the parallel bus:

ICs on the Parallel Bus		
Name	Number	Purpose
1. Flash ROM	IC205	Start up program instructions
2. Hybrid Gate Array	IC601	Expansion port for System Control IC202
3. SRAM	IC204	IC202's local memory
4. AV Decoder	IC401	Audio (AC-3) and Video (MPEG 2) decoder
5. ARP2	IC303	CD/DVD data processing & separation
6. Servo DSP	IC701	Analog servo control

Bi-directional communications between these ICs are accomplished using the following lines; however, not all ICs use the last three lines:

- Chip Select from IC202
- Address from IC202
- Data (bi-directional)
- Clock from IC202
- Interrupt from destination IC
- Read/Write from IC202

Chip Select Line

System Control IC202 systematically polls each IC on the communications bus with a chip select signal. This low or high going pulse identifies the individual destination IC that System Control wants to communicate with. The chip select output sequence is listed below:

Chip Select Signals from IC202 (active low)		
CS Source	Destination	Pulse Width/Polarity
1. CS 1 - IC202/pin 10	SRAM IC204 / HGA IC601	0.56us /- 0.9usec/-
2. CE - IC202/pin 11	Flash ROM IC205	0.56us /-
3. CS 2 - IC202/pin 9	AV Decoder IC401	0.7 & .26 usec/-
4. CS 4 - IC202/pin 7	HGA IC601	0.3usec/-
5. CS 3 - IC202/pin 8	AV Decoder IC401	1.2usec/-
6. XCS - IC601/pin 111	ARP2 IC303	0.3usec/-
7. HCS - IC601/pin 118	Servo IC701	0.3usec/-

Chip Select Waveforms

The following waveforms show the chip select signals going to the S RAM IC204 (ch 1) and AV Decoder IC401 (ch 2 and 3). They can be compared to the D1 data (ch 4) to show that the chip select (ch 1-3) signals occupy more than one bit clock interval. Note that on each of the CS 1 (ch 1) and CS 2 (ch 2) lines, two different pulse widths are used. These waveforms were taken with the unit on without a disc being played.

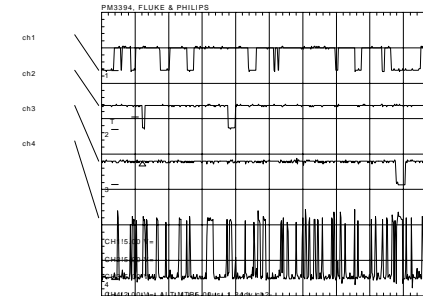

Chip Select signals from IC202 (active low)			
	Name	Location	Voltage/div
Channel 1	CS = CS1	IC202/pin 10	5Vp-p
Channel 2	CS = CS2	IC202/pin 9	5Vp-p
Channel 3	CS = CS3	IC202/pin 8	5Vp-p
Channel 4	Data = D1	IC202/pin 26	2Vp-p
Time base	5usec/div.		

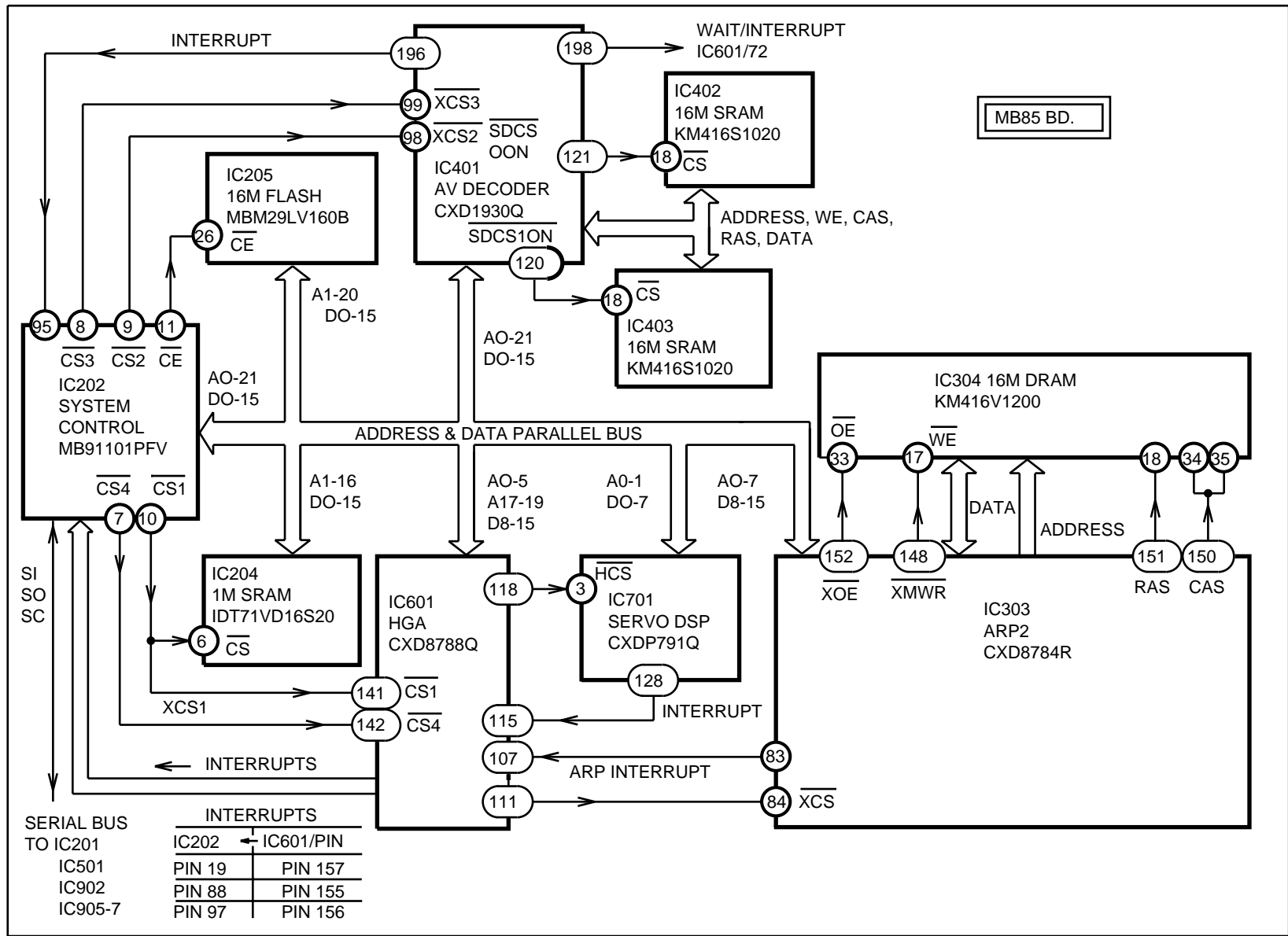

PARALLEL DATA COMMUNICATION

5DVD02 1146 6 29 99

Address Lines

Direct Addressing

The parallel bus in this unit contains multiple address lines to designate the destination of the data within the IC that is chip selected. These address lines are labeled A0-21 from master IC202. Address lines are shared by some destination ICs and none use all 22 address lines.

Column and Row Addressing

IC401 and IC303 control three memory ICs. A memory IC has more data locations than can be accessed by one set of address lines directly. CAS and RAS lines are used to expand that number. Memory locations can be addressed like cells in a multiplication table. For example, when CAS is active, the address lines identify a column of memory locations. Then when RAS is active, the address lines now pin point the memory cell by identifying the row it is in.

Data and Clock Lines

Serial data communications involve the fewest number of connections between ICs. When speed is important, the parallel data structure is used. Instead of having a single data line between the communicating ICs, there are 8 or 16 lines that carry data. As in the serial bus structure, on a separate line the parallel bus uses a bit clock signal. When a single bit clock pulse occurs, the entire group of 8 or 16 bits of data is transferred at once. Therefore, the data transfer rate of the parallel bus system is much faster than the serial bus.

Interrupt Lines

Interrupt signals are used when the destination IC has carried out the instruction given to it and wants to reply with resultant data (such as task completed or information such as AC-3 detected). A destination IC can not generate a clock or chip select lines to send data to the master IC202. The destination IC must send an interrupt signal to the master IC202 requesting attention. When the master IC202 is ready, it will send chip select and clock signals, allowing the destination IC to send data.

Read / Write Lines

Bi-directional communications on the parallel bus may use a single write enable (WE) / read enable (RE) line from the master IC202. During the chip select interval, this line determines the direction of the data to or from the master IC202. A high is one data direction while a low is the other. In some systems, two individual read and write lines are used.

When there are no interrupt, WE or RE lines, communications are pre-established to share the time to read and write during the chip select interval.

Communications from IC202 to Other ICs

IC202 can only send data to another IC after it chip selects the IC and supplies internal address and bit clock to carry the data. Consequently, a list of communications from IC202 would consist of the following:

- Chip Select (usually active low)
- Write control line (usually active low)
- Address data (Identifies the registers/memory location in the destination IC to put the data)
- Bit clock
- Data

Communications from Another IC to IC202

If another IC has finished a task and wants to reply with sensor information, it must request the service (signals) above to return data. Once the destination IC sends an interrupt pulse, IC202 will reply with all the signals listed above so the other IC can send data to IC202.

The Read control line (from IC202) is active instead of the write line in the date reply to IC202. All or some of the address locations are checked by IC202. The number is dependent upon the firmware built into Syscon IC202. For example, IC202 may request the Servo IC701 perform a sled movement to home task. Later IC202 receives an interrupt from IC701. Instead of checking all of IC701's address locations, it will just access the one that contains the sled at home data.

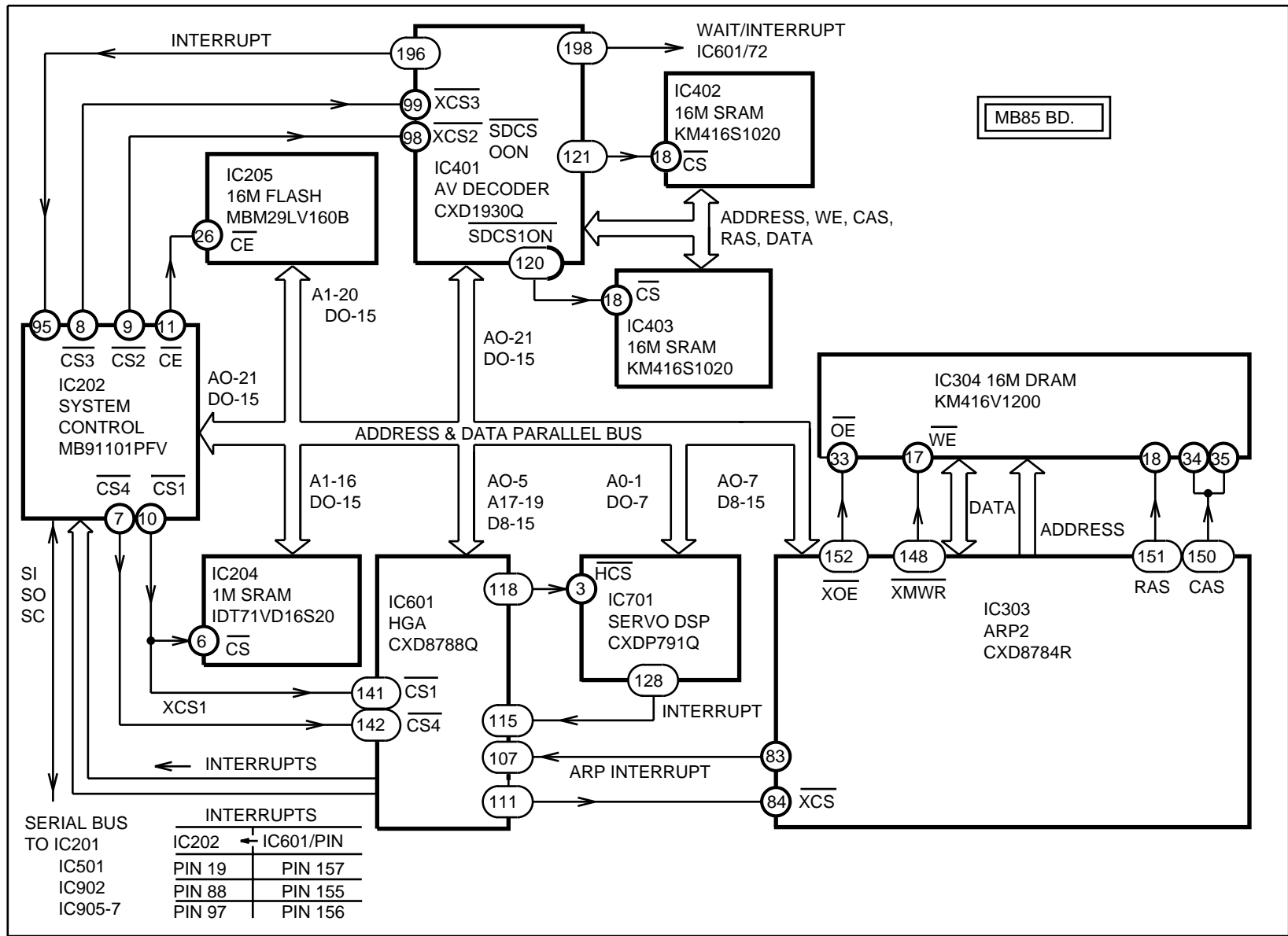

PARALLEL DATA COMMUNICATION

5DVD02 1146 6 29 99

Mechanism

Disc Tray and Laser Platform Position

Tray Movement

The loading motor moves the disc tray in or out. Without the tray, the loading motor's shaft is seen on the right side.

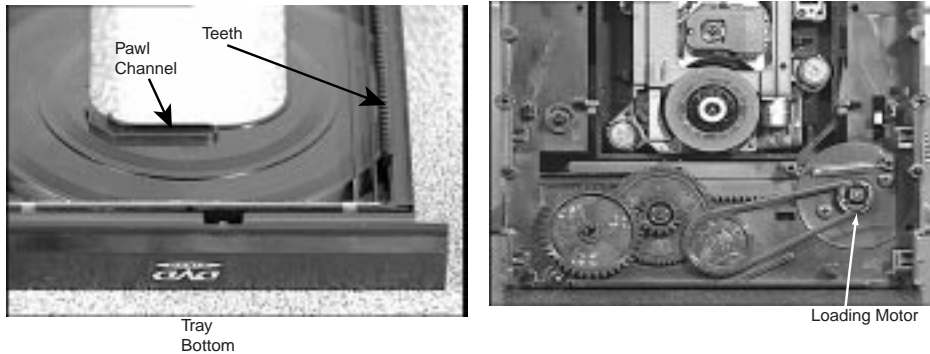

Top View

The rotation of the motor turns the three gears to its left. The final gear at the far-left mates with the teeth on the tray. Motor direction determines tray movement. Electrical feedback to stop the motor is an opened/closed electrical switch under the white activator arm. The tray at the end position pushes the arm.

Platform Position

When the loading motor drives the tray inward, a channel in the tray moves a spring-loaded pawl into the middle rotating gear. The gear's rotation continues to slide this pawl to the left. The front part of this pawl that faces the laser assembly platform lifts a pin connected to the platform. As the pawl slides left, the platform is lifted up. The pawl in the tray's channel prevents the tray from sliding out.

No Power Tray Removal – From the Bottom

A spring-loaded pawl under the tray locks the tray closed. The bottom part of this pawl can be accessed from under the mechanism assembly.

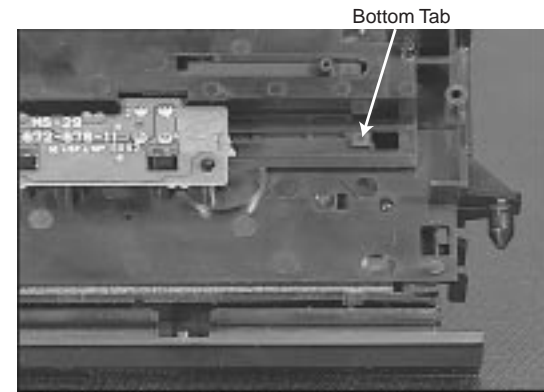
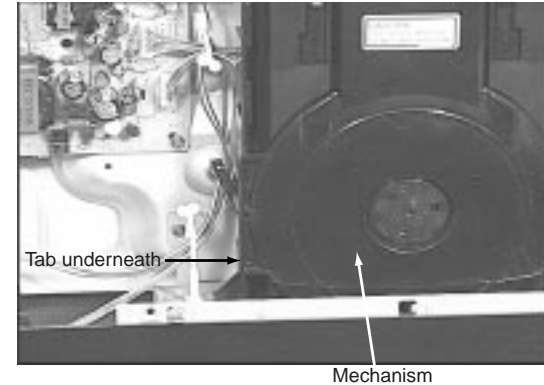

1. Unplug AC power and press the power button to discharge the power supply capacitors.
2. At the mechanism top, remove the two screws and the mechanism's top cover. The cover acts as a tray stop. Cover removal allows the tray to be pulled out later.
3. At the rear of the mechanism remove the rear black screw for finger clearance.
4. Place your finger under the mechanism. Push the slider's bottom tab.
5. At the bottom of the assembly, slide the tab toward the center of the mechanism. This lowers the laser (unchucks), freeing the tray.
6. From the top of the mechanism, slide the tray out

No Power Tray Removal – From the Top

1. Remove the two screws and the mechanism's top cover to expose the tray and laser platform.
2. Locate the top pawl under the tray by inserting a small screwdriver between the platform and tray. The pawl is just in front of the spindle motor.

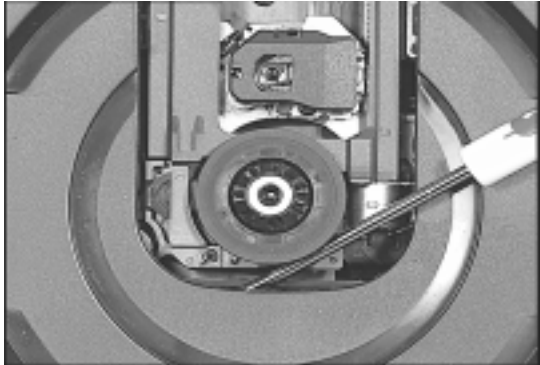

3. Slide the pawl to the right to lower the platform and free the tray.
4. Remove the tray.

Tilt Motor

Purpose

Maximum RF output level occurs when the laser beam is perpendicular to the disc's information layer. The tilt motor raises one end of the laser platform so its beam is perpendicular to the disc.

Access and Operation

The tilt motor is a stepping motor located next to the incline gear. At power OFF, the incline gear lowers one end of the laser platform. At power ON, the incline gear raises the platform to full height.

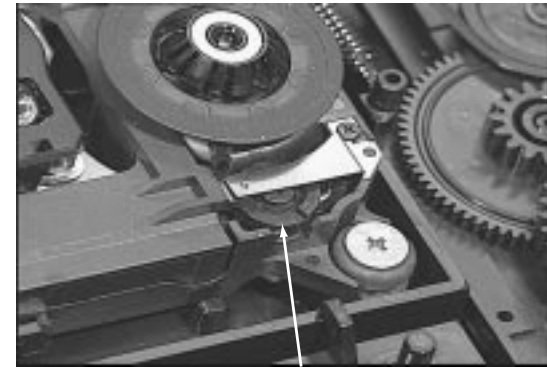

Incline Gear

The stepping motor then increments the incline gear to the middle position. This position is stored in EEPROM IC201 and updated during the test mode automatic adjustments. During DVD playback, if the RF level fluctuates, the tilt motor rotates until the RF level stabilizes. The incline gear remains at the middle position during CD playback.

Sled Position

The sled motor moves the laser assembly away from home position at the spindle motor. The laser assembly's home position is marked as it blocks the light to a photo detector sensor. This picture shows the photo-sensor location under the sled motor shaft.

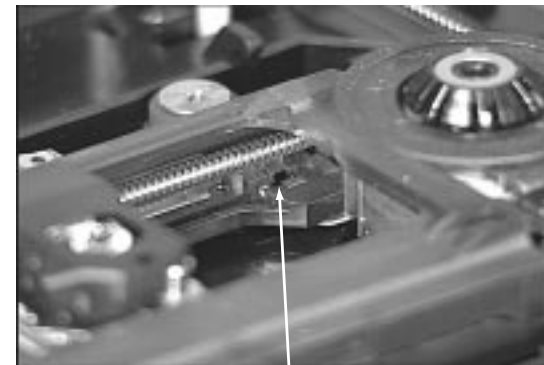

Sled Sensor

Focus Coil

Voltage applied to the focus coil that is connected to the lens opposes a stationary vertical magnet. The force generated moves the objective lens up or down to focus the laser spot on the information layer of the disc.

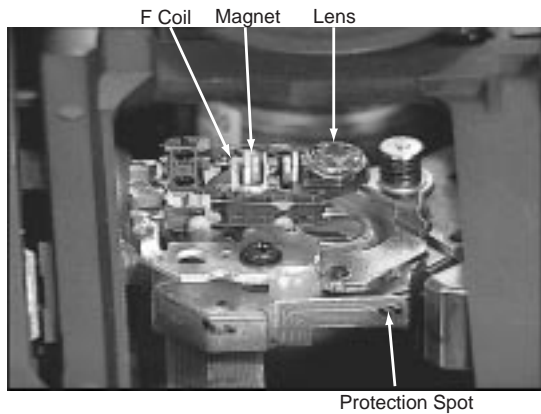

Laser

A ribbon cable connects the laser assembly to its circuit board. A circuit board connector clamps the assembly's ribbon cable. Free the cable from the connector by pulling the connector tabs on both sides 1mm toward the cable. The connector will slide out..

In this picture the left side of the cable is free from the connector.

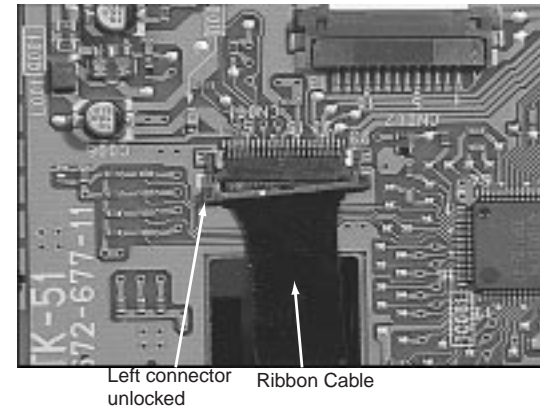

In a replacement laser assembly, a spot of solder is placed on the foils of the ribbon cable (see the focus coil picture) to protect the laser diode from static damage that will shorten its life. Remove the solder spot AFTER connecting the laser assembly cable to the circuit board.

Power ON Mechanical Sequence – No Disc	
Operation	Purpose
1. Power On button is pressed.	IC202 retrieves start up program from Flash ROM IC205. After the ICs are checked for basic communications, IC202 instructs Servo IC701 to start the mechanical sequence. The servo parameters are stored in EEPROM IC201.
2. Disc tray is closed (if open) and placed into a chucked position.	Clamps a disc on the spindle motor platform.
3. Sled moves the optical assembly to home position.	Sled starting point.
4. Tilt Motor resets laser platform to mid position.	Presets the laser beam perpendicular to the disc for max RF.
5. Sled moves outward quickly, then slows down.	Optical assembly is moving under the disc's information area.
6. Laser is turned ON momentarily during focus search.	Looks for a disc. Reflected light identifies a disc.
7. Focus search one time.	Optical assembly lens moves up then down, looking for the disc's information layer.
8. Sled increases speed moving further outward.	Sled slows down in a second attempt to locate a disc.
9. Sled slows down	
10. Laser is turned ON momentarily during focus search.	Looks for a disc using reflected light.
11. Focus search.	Looks for the disc's information layer.
12. Sled again moves quickly outward then slows, followed by laser and focus search.	Third attempt to locate a disc.
13. Sled moves inward to home and stops.	Disc check at home position.
14. Laser is turned ON momentarily.	Final attempt to identify a disc.
15. Focus search.	
16. Spindle motor rotates.	(laser is off)
17. Display reads NO DISC	User feedback

Power ON Mechanical Sequence – DVD Disc	
Operation	Purpose
1. Power On button is pressed.	IC202 retrieves start up program from Flash ROM IC205. After the ICs are checked for basic communications, IC202 instructs Servo IC701 to start the mechanical sequence. The servo parameters are stored in EEPROM IC201.
2. Disc tray is closed (if open) and placed into a chucked position.	Clamps a disc on the spindle motor platform.
3. Sled moves the optical assembly to home position.	Sled starting point.
4. Tilt Motor resets laser platform to mid position.	Presets the laser beam perpendicular to the disc for max RF.
5. Sled moves outward quickly then slows down.	Optical assembly is moving under the disc's information area.
6. Laser is turned ON momentarily during focus search.	Looks for a disc. Reflected light identifies a disc.
7. Focus search one time.	Optical assembly lens moves up then down, counting the number of disc layers.
8. Sled stops moving when a disc is identified.	
9. Spindle motor rotates.	Rotates the disc.
10. Laser is turned ON a second time.	To begin playback.
11. Focus search.	Focuses on the first information layer on the disc.
12. Focus servo is turned ON.	Maintains focus on the layer.
13. Tracking begins.	Keeps the laser beam at the information track's center.
14. Tilt motor servo starts.	Maintains high RF level.
15. Disc PB begins. Display shows elapsed time.	Playback verification.

NOTES

Tray Motor Drive

The opening and closing of the disc tray involves two micro controllers, one gate array IC and a driver IC that powers the loading motor. The loading motor is powered by pressing the front panel open/close tray button S212. The following occurs when the tray button is pressed:

1. Interface Controller IC201 recognizes the tray button
2. IC201 turns on the display to show the command entered
3. IC201 communicates with System Control IC202
4. IC202 instructs Hybrid gate array IC601 to issue a drive command
5. Driver IC802 translates the command into loading motor current
6. The tray position switch returns information to IC201 (via IC601)

The tray position switch information is sent to Interface IC201 via IC202 to complete the tray open cycle. The "OPEN" display disappears when the cycle is complete. This also sets the latch, permitting the tray to be closed the next time the tray button is pressed.

Interface Controller IC201 Recognizes the Tray Button

Pressing the tray button S212 reduces the voltage at IC201/pin 5 from +5V to +0.65V.

IC201 Turns On the Display

Once the command is recognized by Interface Control IC201, the ND201 fluorescent display digits and segments lines are multiplexed with a LOW to illuminate the word OPEN.

IC201 Communicates with System Control IC202

At almost the same time the display is lit, serial communications occurs with System Controls IC202. The serial communications are always present as long as the DVD player is on, but an additional group of data is output when the S212 tray button is pressed. Serial communications in this DVD player occur in the following sequence:

1. IC201 starts it with a single low (almost undetectable) interrupt pulse from IC201/pin 78 (ch 1). Resistors R036 and R037 reduce the signal for IC601. The input voltage should never exceed the IC's supply voltage.

2. IC601 sends this information along the parallel bus to IC202. This occurs when IC601/pin 142 is periodically (chip) selected using CS1 or CS4 to send and receive data. Two chip select lines are used in different parts of the Hybrid Gate Array IC601.
3. When IC202 is ready, it outputs a low chip select signal (ch 4) from pin 97 to Interface IC201/pin 76. IC203, in-between IC201 and IC202, translates the signal to a 5-volt level for IC201.
4. IC202 simultaneously sends serial clock from pin 78 to IC201/pin 70 (ch 3) during the chip select interval.
5. Data is transmitted from IC201/pin 71 to IC202/pin 76 (ch 2).

As seen below, the group of waveforms on the left in "tray 1" are of the serial communications between IC201 and IC202 when the DVD player is on. It consists of a low going interrupt pulse used for triggering at channel 1. This is better seen in the tray 2 waveform group taken at an expanded time base. Shortly after interrupt (ch 1), clock (ch 3) and a chip select (ch 4) pulse appear. Then data (ch 2) is transmitted to IC202.

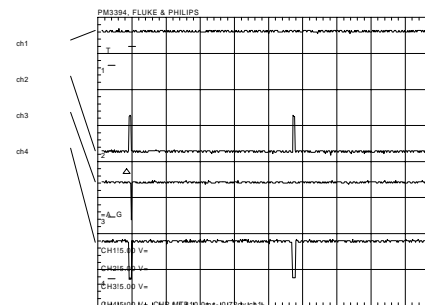

Waveform = tray 1

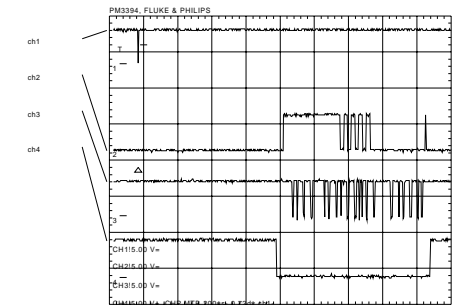

Waveform = tray 2

Waveforms Tray 1 and 2 = DVD Player Powered ON			
	Name	Location	Voltage/div
Channel 1	XIFint(interrupt)	CN006/pin 2	5Vp-p
Channel 2	Serial data (to IC202)	CN006/pin 4	5Vp-p
Channel 3	Serial clock (SCO)	CN006/pin 6	5Vp-p
Channel 4	Chip select (CSOL)	CN006/pin 3	5Vp-p
Time base	Tray 1 = 10msec/div. Tray 2 = 0.2msec/div		

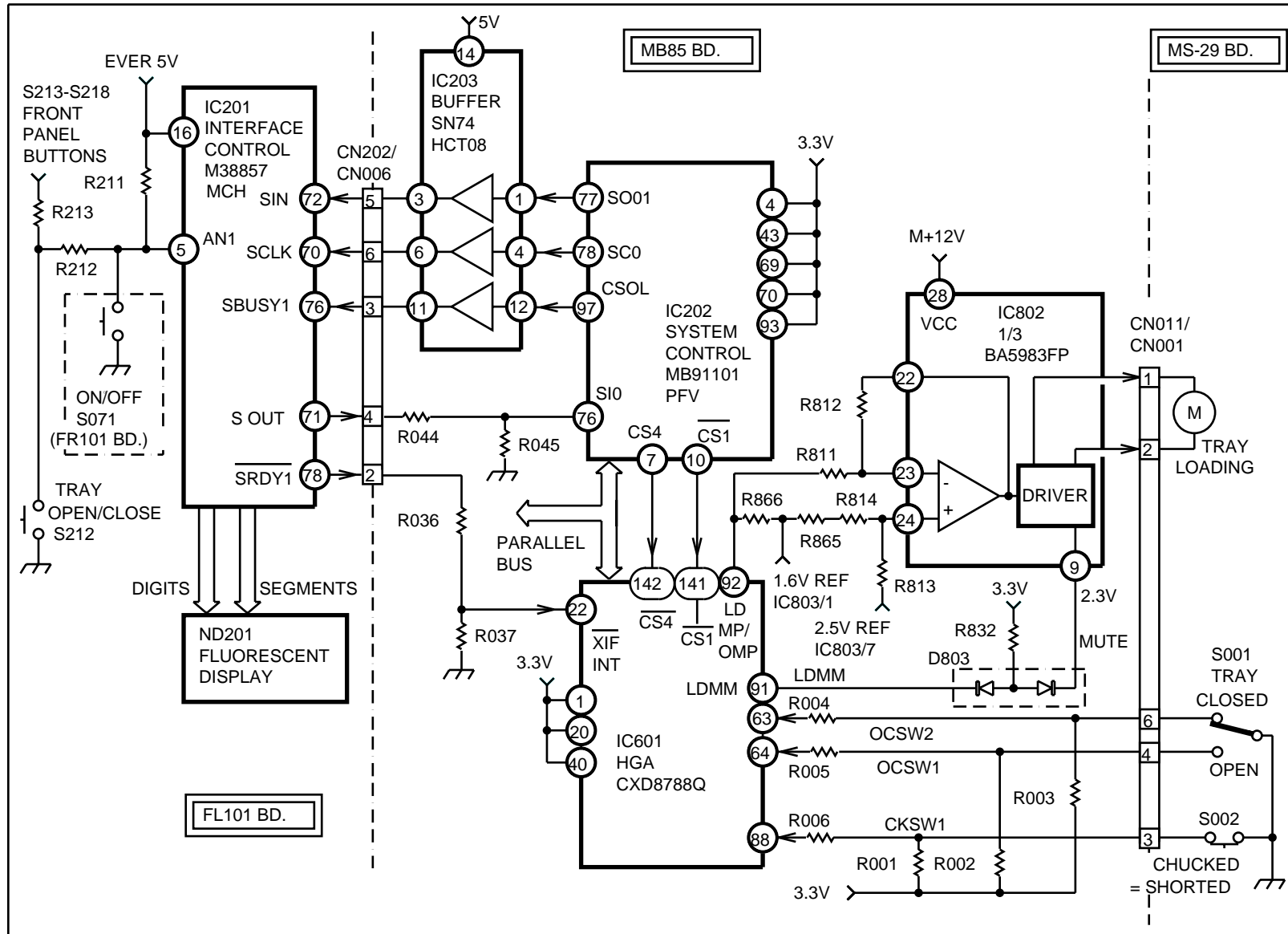

TRAY MOTOR DRIVE

The “tray 3” group of waveforms below are taken of the serial communications occurring when the front panel tray button S212 is pressed. Note that when comparing these waveforms to the group of “tray 1”, an extra set of communications takes place 20msec later.

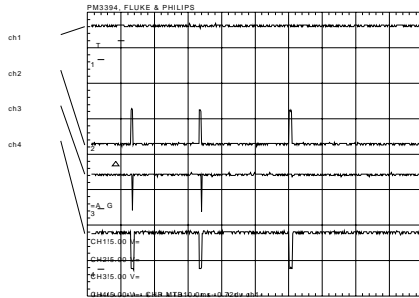

Waveforms Tray 3 = Tray Button Pressed			
	Name	Location	Voltage/div
Channel 1	XIFint(interrupt)	CN006/pin 2	5Vp-p
Channel 2	Serial data	CN006/pin 4	5Vp-p
Channel 3	Serial clock (SCO)	CN006/pin 6	5Vp-p
Channel 4	Chip select (CSOL)	CN006/pin 3	5Vp-p
Time base	10msec/div.		

IC202 Instructs Hybrid Gate Array IC601

System Control IC202 coordinates and controls many operations. A Hybrid Gate Array IC601 is used to interface IC202 to other ICs for analog and digital operations. Information is sent between IC202 and IC601 using a parallel bus and chip select lines. Communications between these two ICs occurs when IC202/pins 7 and 10 applies a low to chip select IC601/pin 142 & 141.

From this communication, the Hybrid Gate Array IC601/pin 92 outputs the loading motor command using tri-state output. When the output is open circuited, the loading motor does not turn. A high causes the tray to open (extend).

IC601/pin 91 is grounded when the tray is out. This low is brought to IC802/pin 9 to prevent the tray motor from moving (inhibited).

Loading Motor Command	
Tray Motion	Command Voltage at IC601/pin 92
Stopped	1.6V (open circuit)
Opening	3.2V
Closing	0V

Driver IC802 Translates the Command

Driver IC802 applies the voltage necessary to turn the loading motor. The loading motor moves the tray. As the tray moves in, the motor pulls up the laser platform.

Tray Drive Voltages		
Tray	CN011/pin 1	CN011/pin 2
Stopped	5.7V	5.7V
Opening	7.36V	3.5V
Closing	3.6V	7.6

Tray Position Switch Returns Information to IC201

Two switches under the transport on the MS-29 board detect the tray and laser platform position. Both of these switches return status information to Interface IC201.

Tray position switch S001 stops the loading motor during tray open. IC601 receives the switch information and opens drive pin 92 to stop the loading motor. Both S001 and S002 stop the motor during tray close.

Tray Position Switch Voltages			
	Tray Position Switch S001		Chuck Switch S002
Tray	CN011/pin 3	CN011/pin 4	CN011/pin 6
Open	3.2V	0V	3.2V
Closed	0V	3.2V	0V

S001 and S002 switch information pass IC601 and IC202 to IC201:

1. This information completes the tray position logic so the motor can reverse rotation with each press of the tray button.
2. Activates the loading motor if the user has pushed the tray in. If IC201 does not receive the correct tray closed or open feedback, the loading motor will be instructed to reverse direction.

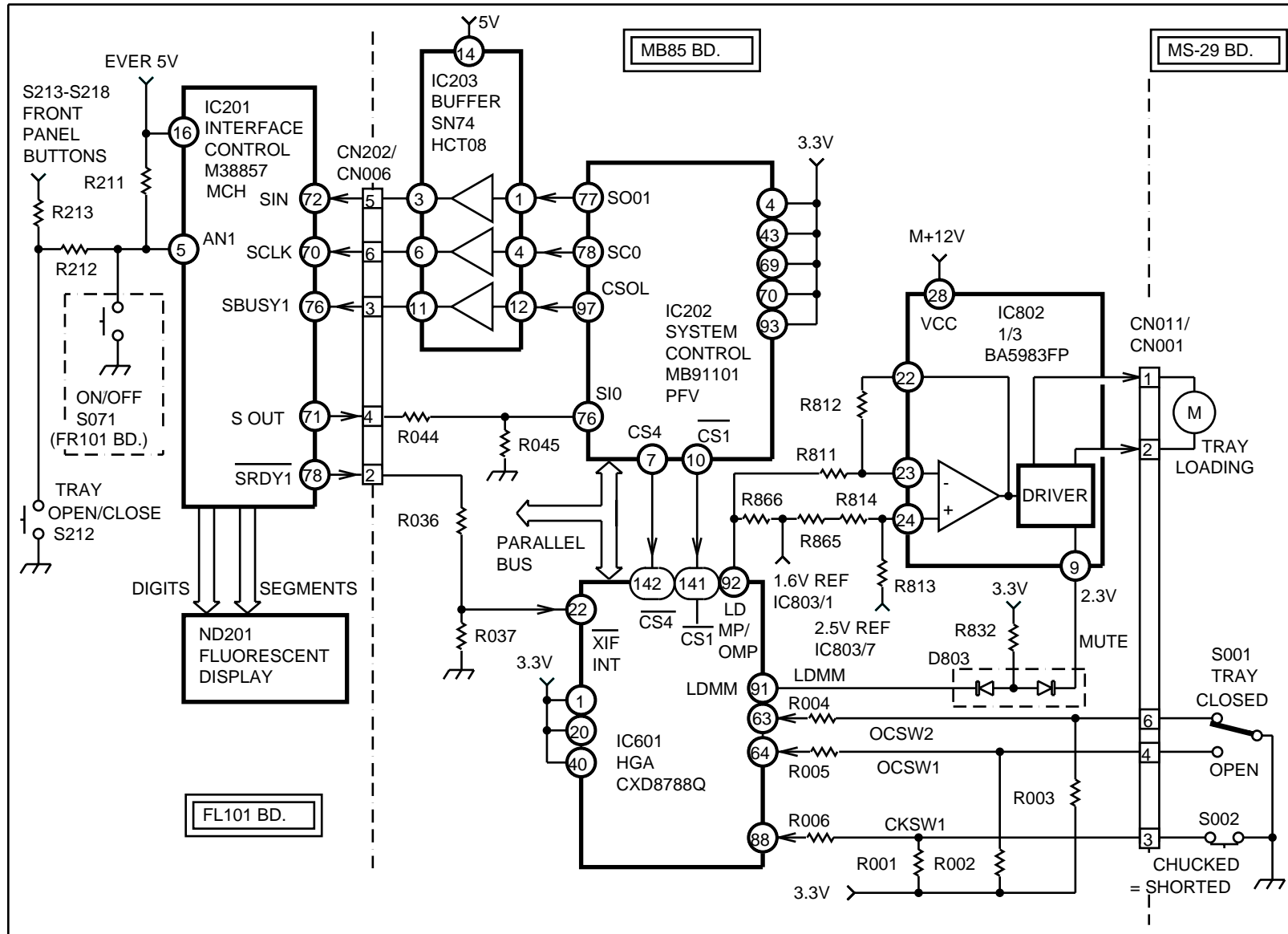

TRAY MOTOR DRIVE

7DVD02 1147 6 23 99

Initial Sled Motor Drive

Initial Sled Movement

Start

When the laser's platform is lifted to a level position, the disc is sandwiched between the spindle motor table and the magnet. In this position the disc is said to be "chucked". The chucked position requires System Control IC202 to retrieve the initial sled program stored in EEPROM memory IC201 (not shown) via the parallel bus.

Movement

The program in IC201 instructs the sled motor to move the laser to home position then quickly outward, but the sled does not stop. It just slows down while the laser and focus search is activated. If a disc is found, the sled stops and playback begins. However, if no disc is found, the sled speeds up and moves outward again further into the disc area. As it slows down a second time, the laser and focus system is instructed to look for a disc (specifically its information layer). If it fails to find it, the sled is quickly moved outward the last time for the third search. The "no disc found" cycle concludes when the sled motor is reversed and the laser assembly is driven home.

ICs Used

System Control IC202 controls the sled motor during this initial disc search stage. A series of ICs are used for this control:

- System Control IC202 uses HGA IC601 as an expansion port
- HGA IC601 instructs Servo DSP IC701
- Servo DSP IC701 issues analog commands to Driver IC802
- Sled Driver IC802 sends voltages to the stepper sled motor

System Control IC202 uses HGA IC601

System Control IC202 plans out the DVD operations, but turns the details of each operation over to a partner IC. It is much like a manager who starts many projects, but has the details of each project finished by a subordinate. When there are too many projects, the manager needs help from an assistant manager to help oversee the activity. System Controls

IC202 employs expansion port Hybrid Gate Array (HGA) IC601 for assistance in managing the remaining ICs.

IC202 to IC601 Communications

When IC202 wants to send data to IC601, IC202 must also send chip select, clock, write pulses and address information to support the data.

IC202 to IC601 Communications Signals		
Signal	Active	Signal Present When:
Chip Select (CS1 or CS4 from IC202/pins 10 or 7))	Low	IC202 & IC205 gets Vcc
Clock IC202/pin 5	Low	IC202 gets B+
Write IC202/pin 22	Low	IC202 & IC205 gets Vcc
Six Address lines HA 0-5		IC202 gets B+
16 Data lines HD 0-15		IC202 gets B+

IC601 to IC202 Communications

When IC601 wants to send reply data to IC202, an interrupt signal is sent to IC202. When IC202 is ready, it will send chip select, clock, read pulses, and address to support the data received from IC601.

IC601 to IC202 Communications		
Signal	Active	Signal Present When:
Interrupt (INT1 or INT3)	Low	An operation is completed (e.g. sled moved)
Chip Select (CS1 or CS4)	Low	IC202 & IC205 gets Vcc
Clock IC202/pin 5	Low	IC202 gets B+
Read IC202/pin 24	Low	IC202 & IC205 gets Vcc
Six Address lines HA 0-5		IC202 gets B+
16 Data lines HD 0-15		IC202 gets B+

HGA IC601 Instructs Servo DSP IC701

IC601 controls many ICs. One of them is Servo DSP IC701. Communications between these ICs use four control lines to transfer the address and data on the parallel bus:

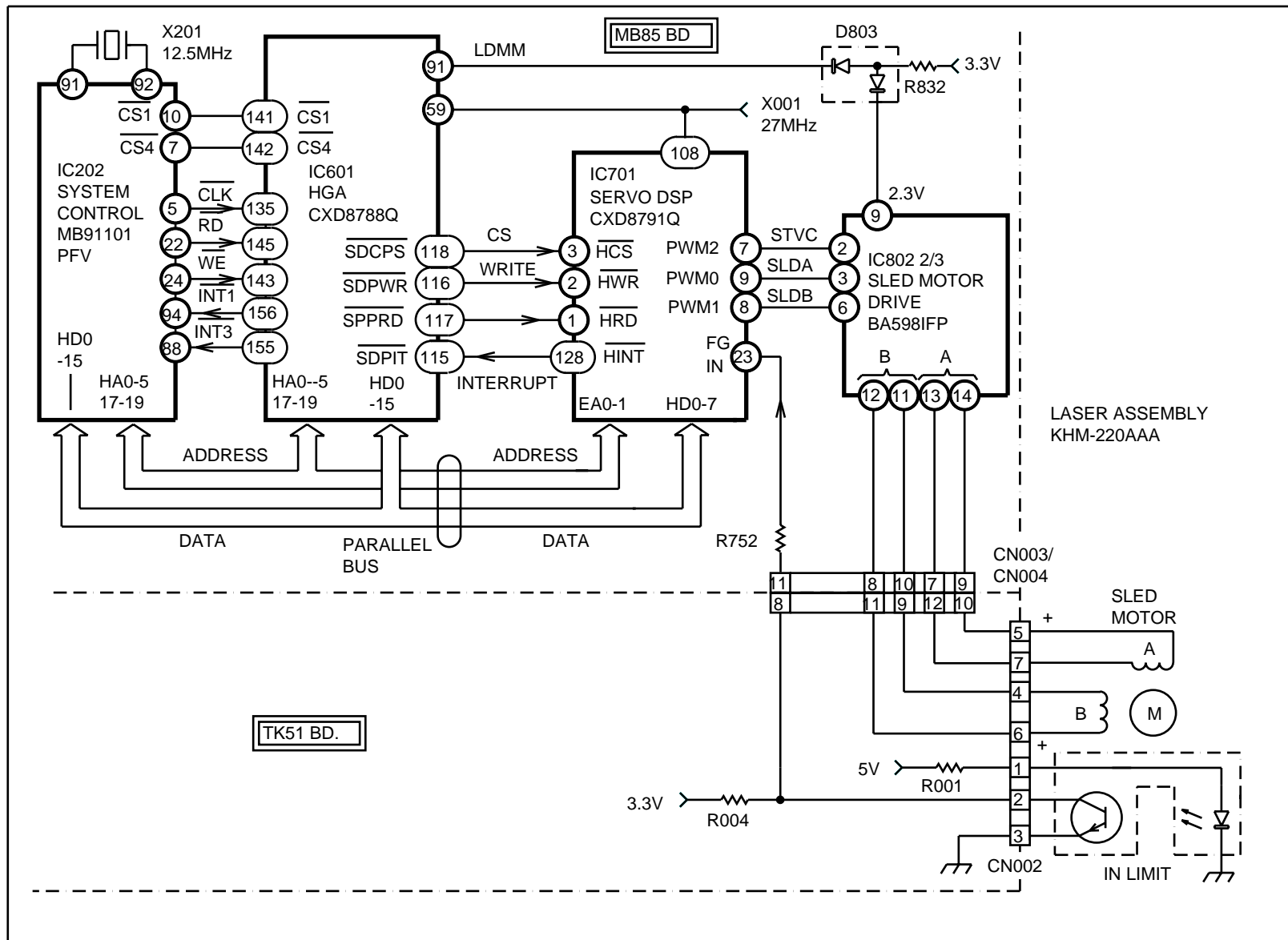

INITIAL SLED MOTOR DRIVE

8DVD02 1148 6 29 99

IC601 and IC701 Communications		
Name	From IC	When Present
1. Chip Select	System Control IC202	Power on/off, playback, tray open close, and start/stop..
2. Read	System Control IC202	Always when powered on
3. Write	System Control IC202	Completion of command (PB, pause, pwr on/off)
4. Interrupt	Servo IC701	Completion of command (PB, pause, pwr on/off)
Address	Bi-directional	Always when powered on
Data	Bi-directional	Always when powered on

Bi-directional communications between IC601 and IC701 are similar to that described for IC202 and IC601. The differences are in the IC pin numbers and that IC601-IC701 communications are only taking place when a servo command is changed.

Communications Waveforms

The following waveforms were taken during a sled forward command initiated from the service mode. They show IC701/pin 3 being chip selected when low (ch 1). This means 16 bits of data (HD0-15) can be transferred at each clock interval when this line is low. The chip select pulse is as wide as three clock intervals. Consequently three groups of data (HD0-15 =16 bits) can be written or read by IC202.

The write line (ch 3) goes low during the chip select interval (ch 1) to identify the direction of the (sled forward) bus data into Servo IC701. The read line is high during this time, meaning it is inactive. The interrupt signal will go low later on after the sled fast forward movement has been completed (ch 4).

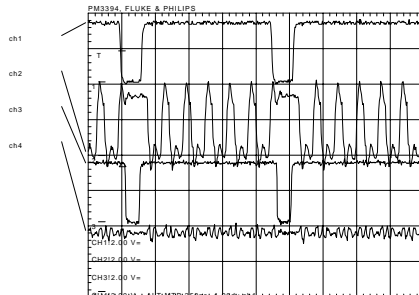

IC601 to IC701 Communications Waveforms			
	Name	Location	Voltage/div
Channel 1	Chip Select (HCS)	IC701/pin 3	2Vp-p
Channel 2	Read (HRD)	IC701/pin 1	2Vp-p
Channel 3	Write (HWR)	IC701/pin 2	2Vp-p
Channel 4	Interrupt (HINT)	IC701/pin 128	2Vp-p
Time base	0.25usec/div.		

Servo DSP IC701 Issues Analog Commands to Driver IC802

Digital commands from IC202 (via IC601) tell Servo IC701 to perform sled operations. First IC701 sends an interrupt signal to IC202 (via IC601), followed by data about the in limit sensor. This data tells IC202 if the laser is at home position (IC701/pin 23 = 0.7V = home).

If the laser is not at home position, IC202 data to the Servo IC701 instructs it to rotate the sled motor until home position is reached.

The sled output of Servo IC701 consists of three 50% duty cycle in phase square waves at about 80kHz. The square wave from IC701/pin 7 is used as reference and does not change. If the square wave from pin 8 or 9 decreases in width, the sled motor rotates. This can be seen in the following waveforms.

Sled Motor Stop Waveforms

The following waveforms were taken of the square waves from IC701 when the sled motor is not turning and when it is moving away from the spindle shaft (outward).

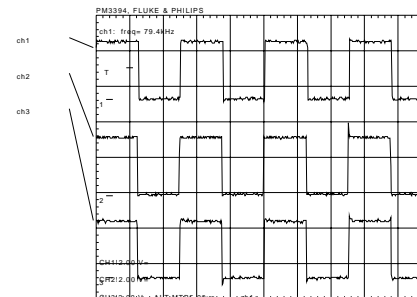

Sled Still

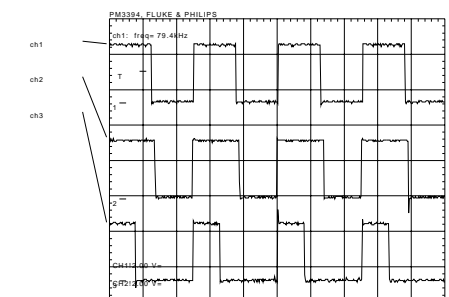

Sled Outward

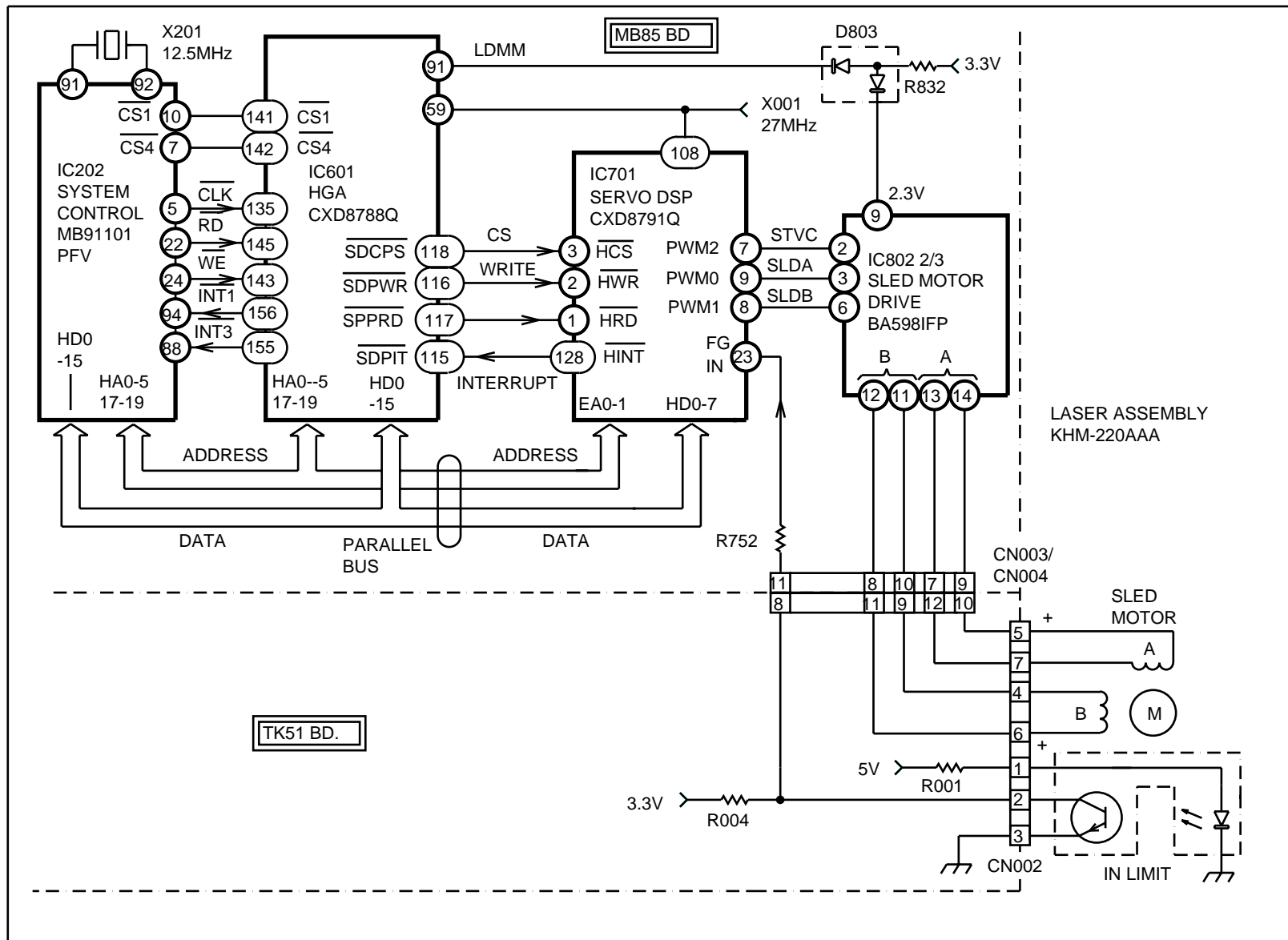

INITIAL SLED MOTOR DRIVE

8DVD02 1148 6 29 99

Sled Stepping Motor			
	Name	Location	Voltage/div
Channel 1	STVC (ref)	IC701/pin 7	2Vp-p
Channel 2	SLDA (inward)	IC701/pin 9	2Vp-p
Channel 3	SLDB (outward)	IC701/pin 8	2Vp-p
Time base	5usec/div.		

The sled motor can be driven manually in either direction to produce the waveforms shown by using the test mode's manual servo control.

Sled Driver IC802 Sends Voltages to the Stepper Sled Motor

When the input pulses to pulse Sled motor Driver IC802 are not identical to the input reference, the sled motor is driven. At the output, if pulses to the B coil of the stepper type sled motor are lower than the pulses applied to the A coil, the sled moves the laser outward. This can be seen in the waveforms taken at IC802's output.

Sled Motor Waveforms

All four sled motor drive signals in these waveforms show that the B coil of the stepper motor gets a reduced amplitude pulse to move the laser assembly outward.

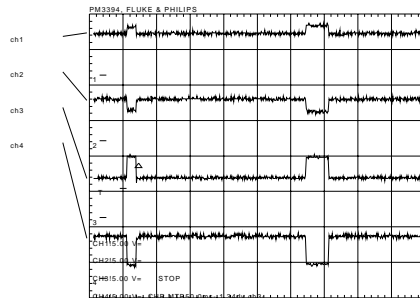

Outward Sled Drive Waveforms			
	Name	Location	Voltage/div
Channel 1	B coil -	CN003/pin 11	5Vp-p
Channel 2	B coil +	CN003/pin 8	5Vp-p
Channel 3	A coil -	CN003/pin 7	5Vp-p
Channel 4	A coil +	CN003/pin 9	5Vp-p
Time base	50msec/div.		

Sled Drive Mute/Inhibit

The sled and loading motors are inhibited when the tray is out. IC601 performs this operation by grounding IC802/pin 9 to stop the driver IC802.

Driver IC 802/pin 9 Mute/Inhibit	
IC802/pin 9 Voltage	Mode
2.3V = normal operation	Tray closed
0V = tray loading and sled motors inhibited	Tray open

Home Position Detection

The laser assembly's home position is identified by a in-limit photodetector within the assembly. The photodetector consists of an IR LED and a photo transistor. Light from the LED passes through an open area to turn on the phototransistor, placing CN003/pin 11 at ground level. When the laser assembly arrives at home position, it blocks the light, permitting IC701/pin 23 to go high. IC701 relays this information to Syscon IC201, via IC601 and home is identified.

The verification of this detector is important to determine if IC202 can complete the initial check sequence and remain powered ON.

1. Place the unit in the special test mode (From power OFF, Press front panel buttons RETURN and STOP together. Press MENU on the remote. The unit will power up if IC201 and the power supply are OK).
2. Measure the voltage at MB-85 board, CN003/pin 11.
 - 3V = Laser at home (by the spindle motor)
 - 0V = Laser away from home
3. You can manually push the metal laser base to slide the laser.

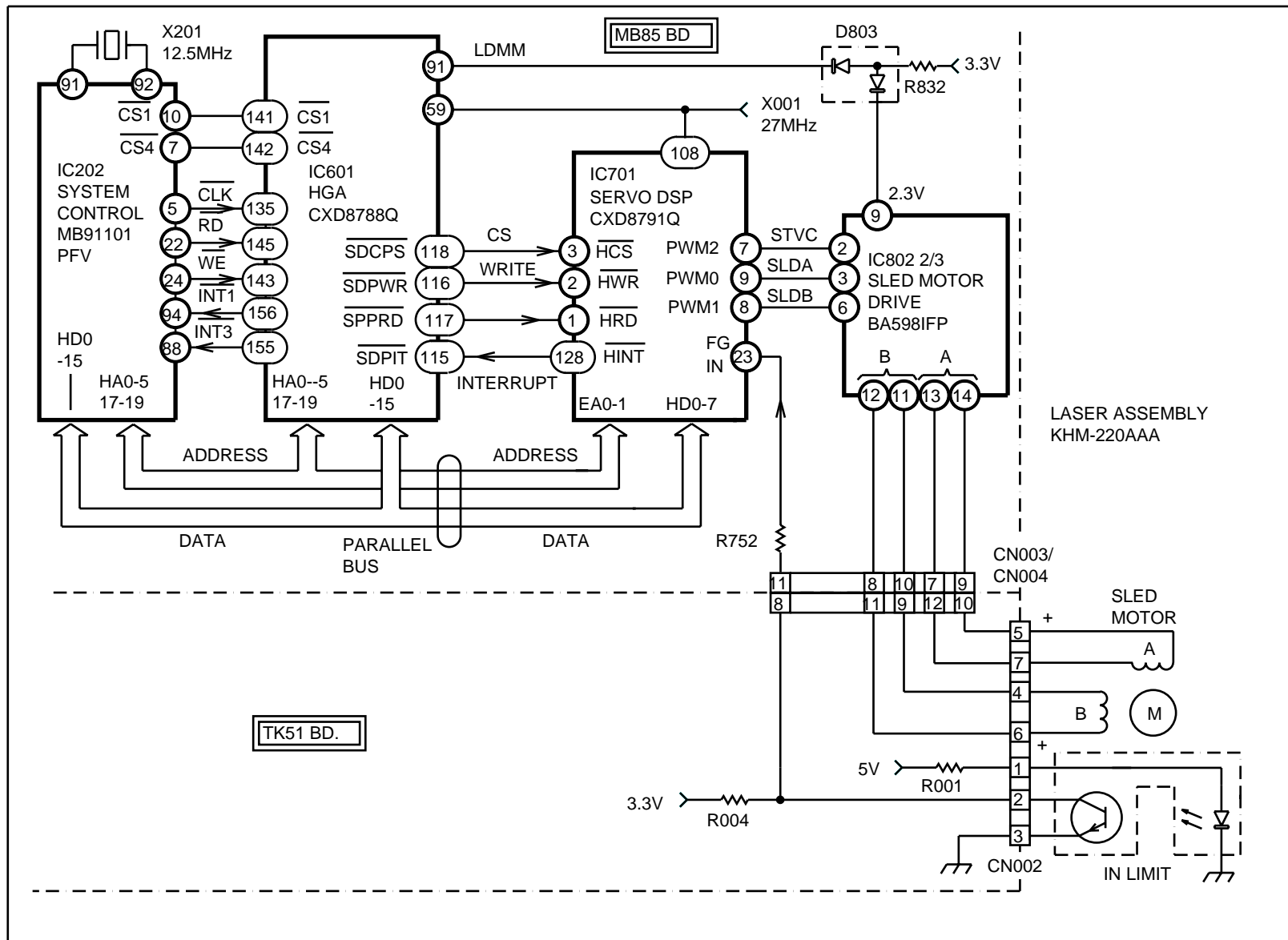

INITIAL SLED MOTOR DRIVE

8DVD02 1148 6 29 99

Laser Servo

After the disc tray is closed (disc chucked/platform up), the laser is turned on. The laser on command takes this six-step path from IC202:

1. System control IC202
2. HGA IC601
3. Servo DSP IC701
4. DVD/CD RF Amplifier IC001
5. Q101
6. DVD/CD Laser Module

System Control IC202 and HGA IC601 Communications

After System Control receives the platform up verification (S002 in the Tray Motor Drive diagram), it gives the command to move the sled to the home position, then outward. The laser is timed by IC202 to turn on about the time the sled has already moved away from home position and is resting under the disc.

HGA IC601 to Servo DSP IC701 Communications

The laser turn on instruction is sent from IC601 to DSP IC701 using the parallel bus. Since the bus is used by other ICs as well, communication is valid between these ICs when the CS chip select at IC701/pin 3 is low.

Servo DSP IC701 to RF Amplifier IC001 Communications

The laser turn on command uses three of the four communications lines that interconnect IC701 and IC001:

IC701 – IC001 Communications		
Label	Location	Description
1. SSCS	CN002/pin 5	High for 16 bits of data (load)
2. SSRD	CN002/pin 6	Not used
3. SSWD	CN002/pin 7	Clock
4. SSCK	CN002/pin 8	Data

The following waveforms show the communications between the two ICs when PB is pressed. Waveform group “Comm 2” was taken at an expanded time base. They show that SSCK (ch4) is actually the data line and not the clock. The SSCS (ch 1) marks the 2-byte group of data by

remaining high for 16 bits. SSWD (ch 3) is the clock signal, and not a write command. These waveforms are only present at disc PB start and stop.

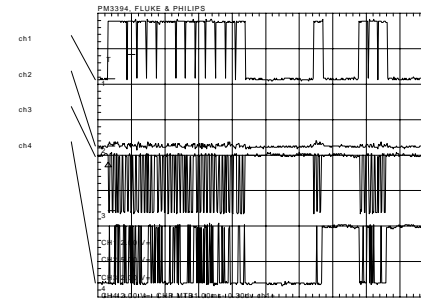

Waveform Comm 1

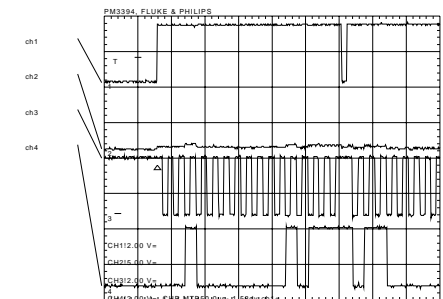

Waveform Comm 2

Communications 1 and 2 when the Play button is Pressed			
	Name	Location	Voltage/div
Channel 1	SSCS	CN002/pin 5	3Vp-p
Channel 2	SSRD	CN002/pin 6	0Vp-p
Channel 3	SSWD	CN002/pin 7	3Vp-p
Channel 4	SSCK	CN002/pin 8	3Vp-p
Time base	Comm 1 = 1msec/div. ; Comm 2 = 50usec/div.		

Laser Life

There are three ways to predict laser life:

- ❑ Laser current – Measures the voltage across R005 at Q001/emitter. New laser = 0.733V. Bad laser will read over 1 volt.
- ❑ Laser operating hours – From the test mode adds the CD and DVD hours. This accumulative information is stored in IC201 EEPROM.
- ❑ Laser light – 0.18mW was measured using the wrong (freq) laser power meter (Leader model 8001). 0.35mW of power is the correct power level using the model 8000 (HeNe position).

DVD/CD Laser Module

The laser turns on when the voltage from CN001/pin 2 = 2 volts. Within the laser module is a light receiving diode that monitors the laser light intensity. This voltage is fed back to IC001/pin 19 for regulation. The voltage is the same for CD and DVD SL PB.

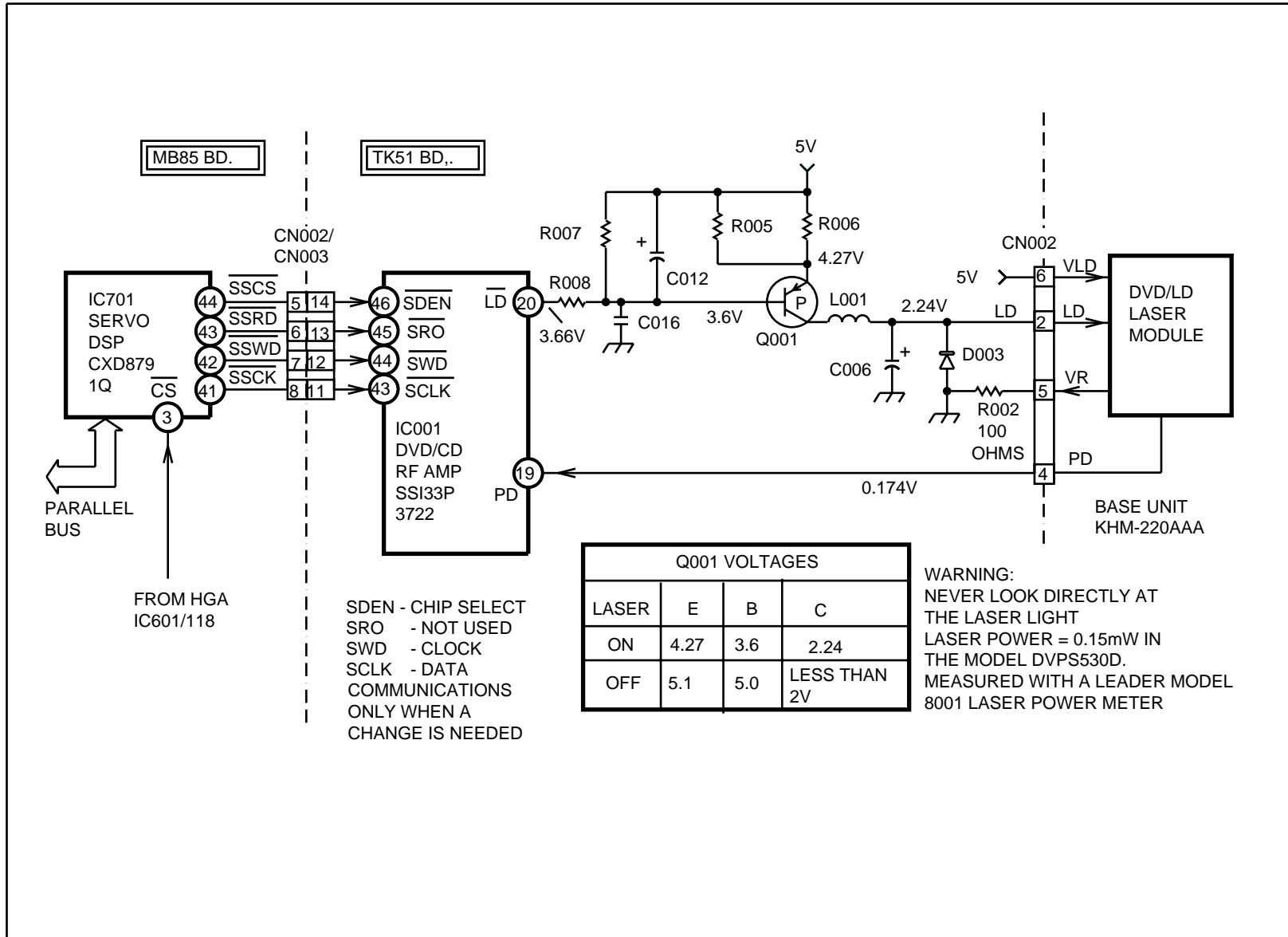

LASER SERVO

9DVD02 1160 6 23 99

KHM-220A DVD Optical Block

Sony DVD players had two independent laser assemblies. One was used to play DVD and the other used to play CDs. In 1999, a single DVD laser in the KHM-220A block was used to play both discs. There were two additional G & H photo detectors added to the optical assembly, but they are not used.

By examining disc focusing, we can see why the lens was altered to playback a CD with a DVD laser.

DVD Focus

Focusing the DVD laser on the information layer of the disc is not simple. The DVD laser must pass through the objective lens before reaching the disc. Like a magnifying glass, this convex lens focuses the beams of light into a point above the lens. As the beam leaves the lens, it passes from air into the polycarbonate CD. This change in medium (density) refracts or bends the light.

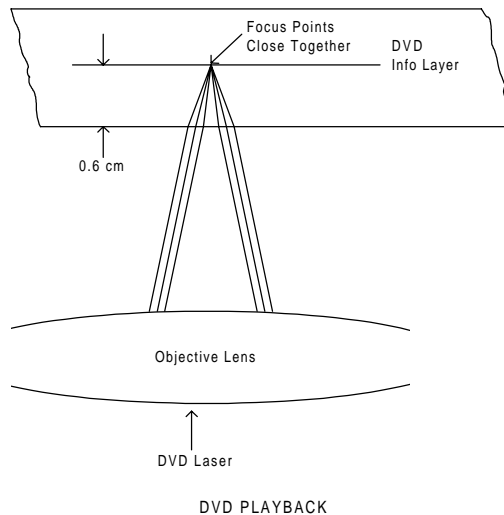

The frequency of the laser, the transition medium and the angle of light entry determines the amount of refraction. Bending of the light as it enters the disc causes a few focus points to form within. The focus points form a short line perpendicular to the DVD's information layer. Because the laser beam only travels a short 0.6cm in a DVD disc before arriving at the information layer, the number of valid focus points is limited.

CD Focus

The information layer within a DVD is at the center of the disc. The information layer in a CD is at the top. The laser beam has to go further into the CD disc.

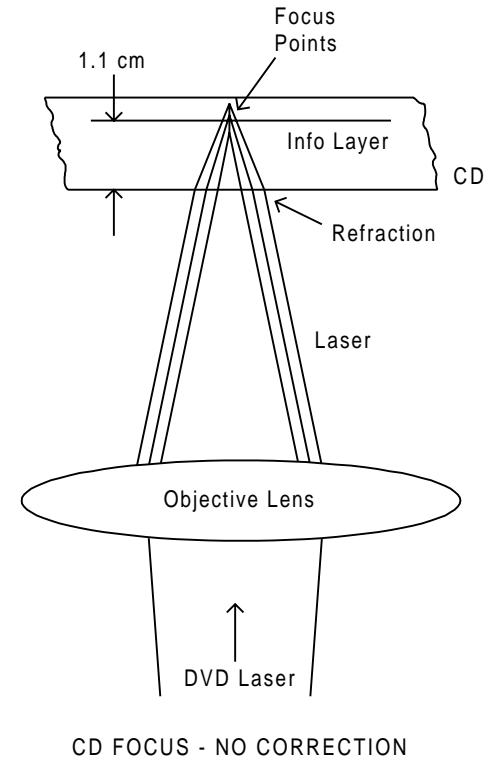

Because the beam must go further, the focus points are spread into a longer line perpendicular to the CD's information layer. Any point along this line results in a correct focus point, causing focus variations and RF eye pattern fluctuations.

This focusing aberration was corrected by reshaping the objective lens to read the CD. The lens changes the angle of the light as it enters the CD, reducing the number of focus points. The beam can now focus on the CD layer, but the objective lens must move slightly higher to compensate for the angle change.

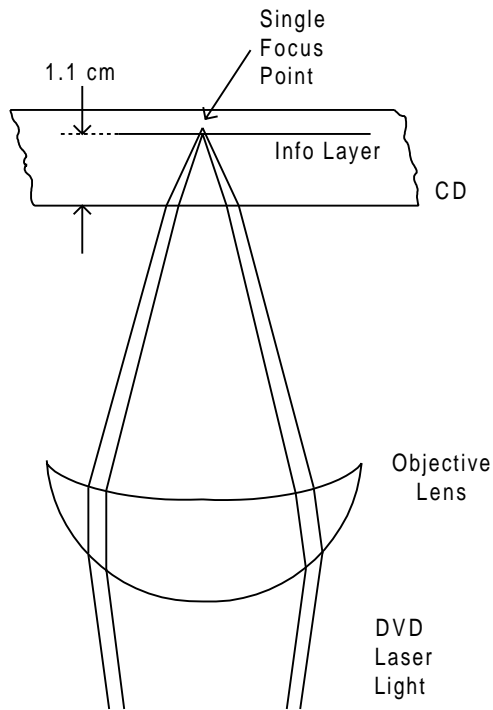

CD FOCUS CORRECTED

Three Laser Beams from One Laser

Although there is one laser, there are three spots of light on the disc's information layer. The three spots are made by diffraction grading inside the laser assembly.

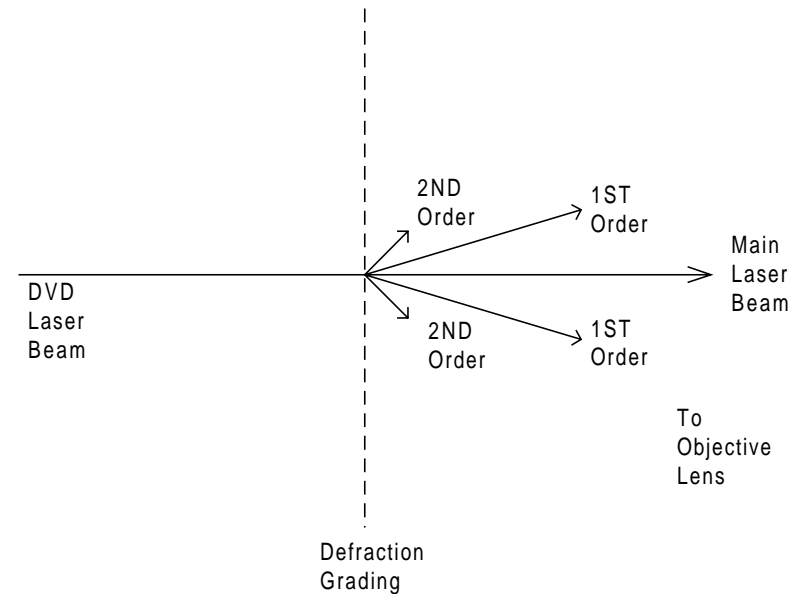

A diffraction grading is made of a glass sheet with lines etched on it forming channels. The channels are represented by the spaces between the dotted lines in the diagram. As the main laser beam passes through a channel, secondary light beams are produced. The first order beams are the strongest and these are the two additional (side) spots that pass through the objective lens onto the disc. These side spots are used for CD tracking.

Photo Detectors

The three beams of light are reflected from the disc and returned to the optical assembly. They land on the photodetectors within these three groups.

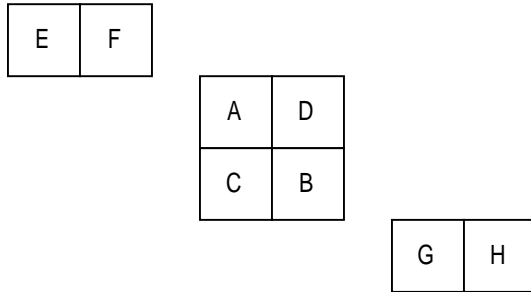

KHM - 220AAA
PHOTO DETECTORS

The voltages from these detectors are matrixed by RF Amplifier IC001 that follows (on the TK-51 board) into servo correction and disc identification signals.

Photo Detector Manufactured Signals		
Photo Detectors	Signals Produced	Purpose
A – D	TE (DVD only) FE, PI, Mirr., RF (eye pattern)	TE – DVD tracking error FE – Focus error PI – “Pull In” is the analog sum of A-D detectors used to ID the disc and create MIRR. MIRR – mirror signal goes high (4V) if PI is above a threshold. MIRR is used to count tracks and ID the disc. RF – Audio and Video Data
E, F *	TE +, TZC	CD Tracking error, track count.
G,H *	TE –, TZC	CD Tracking error, track count

*In CD and older DVD players, there are only two outer tracking error detectors (E & F). In this new laser assembly, two outer detectors were added but they are not used in this player.

The extra detectors are to permit this laser assembly to read DVD-R discs in future players. This DVD player cannot play DVD-Recordable discs even though the laser has the ability to do so. Detectors E & F are added together and treated as one. G & H detectors are also added in the matrix / RF amp IC001 that follows (not shown).

NOTES

Disc Identification

DVD Player models DVP-S330, S530D, S550D and S705D identify the disc during focus search as the laser's objective lens is rising. Photo detector group A-D in the optical assembly is used for this detection process. These detector outputs are matrixed by the RF amplifier IC001 to produce several outputs. Two signals are used to identify one of four discs placed in the player.

Mirror – Voltage created when the light returned from the disc exceeds a threshold. The light is the strongest when focus is near.

Focus Error – Identifies the exact point of focus. The point of focus will occur within the window created by the MIRROR signal.

The Mirror signal is used for disc detection. The focus error signal is used to verify that the mirror signal is a valid one.

Operation

During focus search, the laser's objective lens is instructed to move up and down while light reflected back from the disc is analyzed. As the lens moves up during focus search, so does its corresponding focus point.

Light is first returned when the focus point arrives at the bottom of the disc. This creates the first voltage (disc entry) at the mirror output. A second voltage occurs when the information layer is found. A third voltage occurs if there is a second information layer. The time between the voltages determines the disc type.

For example, in a DVD disc the information layer is closer to the bottom of the disc than a CD. Therefore in a DVD, the second mirror signal will occur sooner than in a CD where the layer is further away.

This disc ID information is initially used to determine the rough speed of the disc. Finally, the disc type is authenticated during playback when the digital data reveals the disc type.

Therefore the first full upward travel of the lens during focus search will identify the disc type.

SACD Disc Type

SACD stands for Super Audio Compact Disc. Although this DVD player can detect the SACD disc, it can only play its normal CD layer (number two). The first layer can contain six channels of uncompressed audio and a PCM audio track. At this time the SACD disc is only available in Japan.

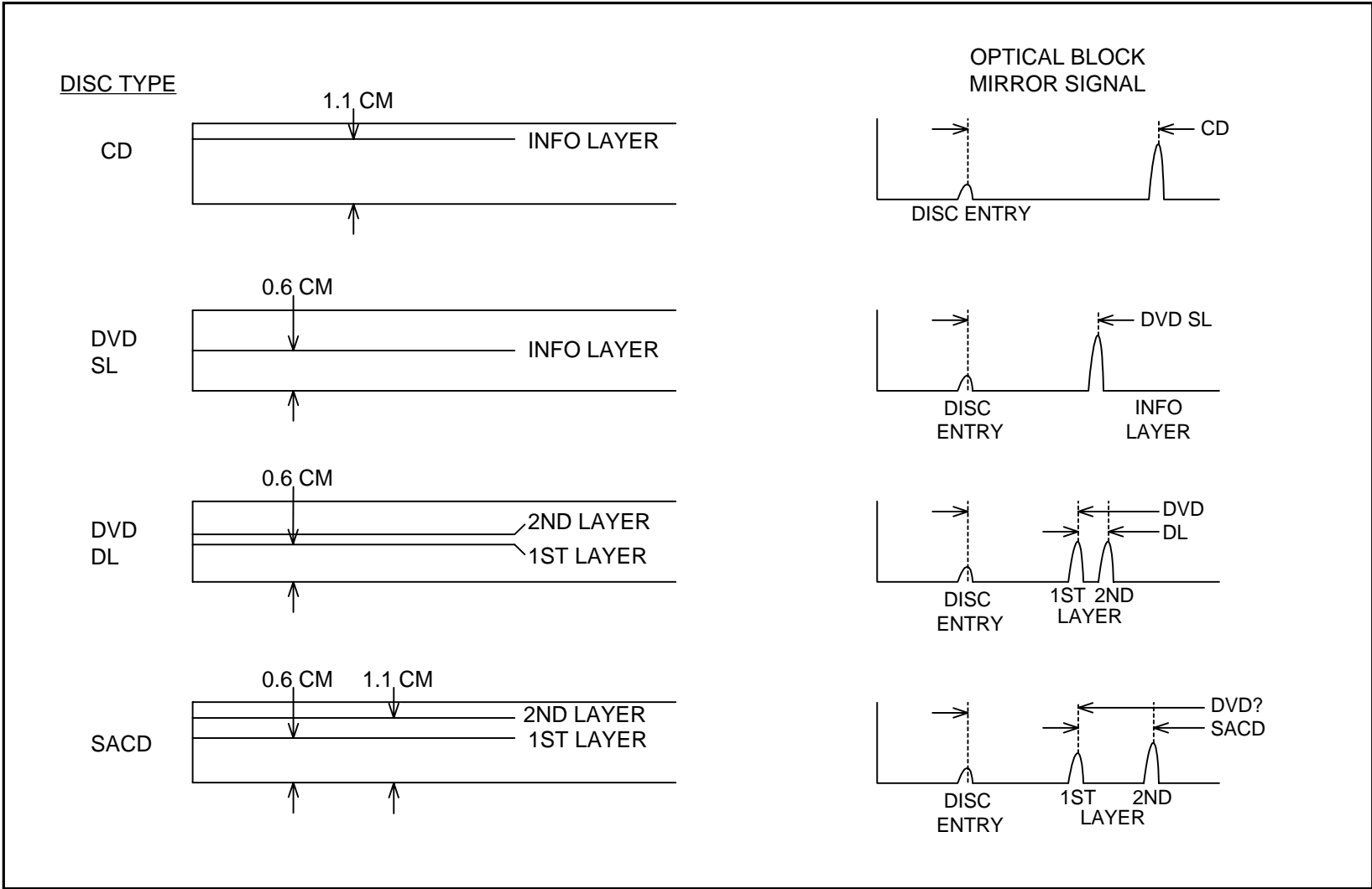

DISC IDENTIFICATION CONCEPT

Focus

Mechanical focus of the laser beam on the information layer of the disc is accomplished by moving the laser's objective (final) lens closer to or away from the disc. Applying a current to a coil that is attached to the lens controls the lens position. When the lens moves up and down, so does its corresponding focus point at the disc area. Focus is found when the laser's focus point rests on the information layer of the disc.

Search

There is a large and a small lens movement associated with focus. The large up and down lens movement is used to locate a disc by moving the focus point until it finds the disc layer. This large lens movement is called focus search and can be seen by observing the lens after the tray moves in.

Focus search employs five ICs and the focus coil. System Control IC202 initiates focus search by sending data to IC701 which makes voltage to move the lens. The results of the search are sent as data from IC701 back to IC202 on the parallel bus so a stop search command from IC202 can follow. Details of the IC202 and IC701 bi-directional communications are explained later.

Focus Search Devices	
Device	Purpose
System Control IC202	Retrieves and acts on the focus search program stored in memory
EEProm Memory IC201	Stores focus search sequence
HGA IC601	Expansion port for IC202
Servo IC701	<ul style="list-style-type: none"> • Translates digital commands to analog focus coil voltages • Identifies disc's layer using IC001
Driver IC801	Voltage to current coil driver
Focus coil	Moves objective lens
RF Amp IC001	Feedback to electrically identify focus

Focus Search End – Disc Identification

Focus search concludes when focus is found or when the search cycle is over and no disc was found. Using A to D laser diode signals from the optical base unit electrically identifies the mechanical focus on the disc layer. RF Amp IC001 combines them to output PI (pin 29) and FE (pin 40) signals. Both are needed to find the focus position and stop focus search. PI identifies a disc when the signal goes high. FE identifies the focus position as this line rises and crosses 1.8V on the way down during search.

Once the focus position has been found, the lens search operation ends and the servo operation begins. IC701 makes the crossover by informing System Control IC202 the disc layer has been found when FCSON from IC701/pin 39 goes high. It remains high as long as focus is maintained by servo IC701.

Servo

Once the disc layer is found during focus search, smaller lens movements maintain focus as the disc is spun during playback. The focus servo uses three ICs to provide small correction voltages to the focus coil:

Focus Servo Devices	
Device	Purpose
RF Amp IC001	Feedback to electrically identify focus
Servo IC701	Identifies disc's layer position using IC001
Driver IC801	Voltage to current coil driver
Focus coil	Corrects objective lens position

The FE signal from IC001/pin 40 is used not only to stop focus search, but also to maintain playback focus. This error signal is amplified and output IC701/pins 7 and 9 to drive the focus coil.

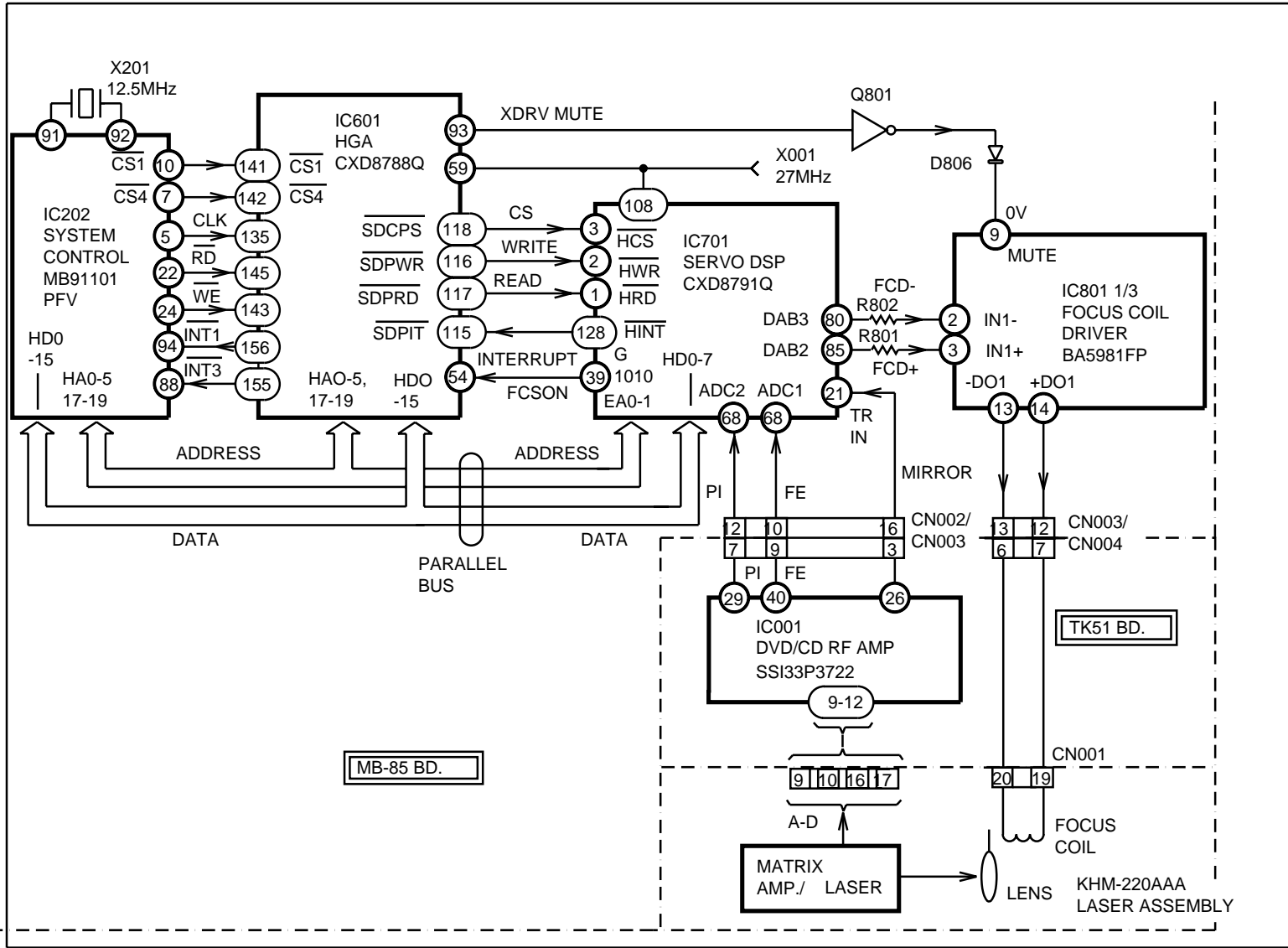

FOCUS

11DVD02 1155 6 29 99

Focus Drive

Servo IC701 outputs two square waves from pins 80 and 85 as long as the set is powered. The reference square wave comes from pin 80 and is fixed at 50% duty cycle. When the duty cycle of pin 85's waveform changes, the focus coil receives current.

The following waveforms were taken during focus search. Note that the falling edge of the reference waveform (ch 2) is always in line with the drive signal (ch 3) from pin 85.

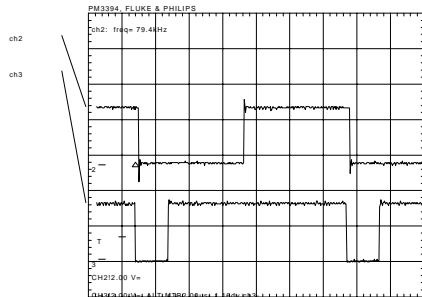

Focus Search Waveforms			
	Name	Location	Voltage/div
Channel 2	FCD -	IC701/pin 80	2Vp-p
Channel 3	FCD +	IC701/pin 85	2Vp-p
Time base	2usec/div.		

This second group of waveforms compares the input and output of the driver IC801 during playback. When there is a change to the duty cycle of pin 9's waveform, there is a differential voltage applied to the focus coil.

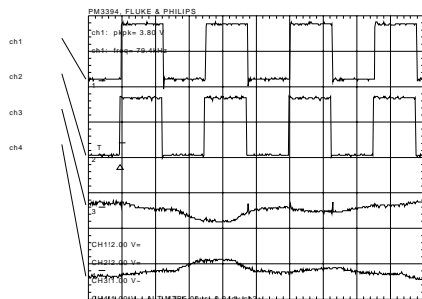

Focus Driver IC801 Input/Output			
	Name	Location	Voltage/div
Channel 1	FCD -	IC701/pin 80	2Vp-p
Channel 2	FCD +	IC701/pin 85	2Vp-p
Channel 3	+ DO 1	CN003/pin 12	1Vp-p AC coupled
Channel 4	- DO 1	CN003/pin 13	1Vp-p AC coupled
Time base	5usec/div.		

Driver IC801 supplies the current to the focus coil within the optical base assembly. The spring suspended focus coil is attached to the lens positioned next to a stationary magnet. The lens is moved when current is applied to the coil. Lens movement changes the laser's focal point.

Focus Search Communications

System Control IC202 to Servo IC701

During focus search, bi-directional communications take place between IC202 and IC701. Since the number of output ports IC202 has is limited, HGA IC601 is used as an expansion port to control the flow of bi-directional information to and from destination ICs such as IC701. All three ICs share a common address and data bus. The information placed on the bus is time-shared by each IC. The time is controlled by System Control IC202.

System Control IC202 to HGA IC701

IC202 cannot communicate with IC701 directly to control servo operations. It must use a middleman - IC601. IC601 handles so many operations it is electronically divided, having two chip select inputs.

When IC202 wants to send data to IC601, IC202 must also send chip select, clock, write pulses and address information to support the data.

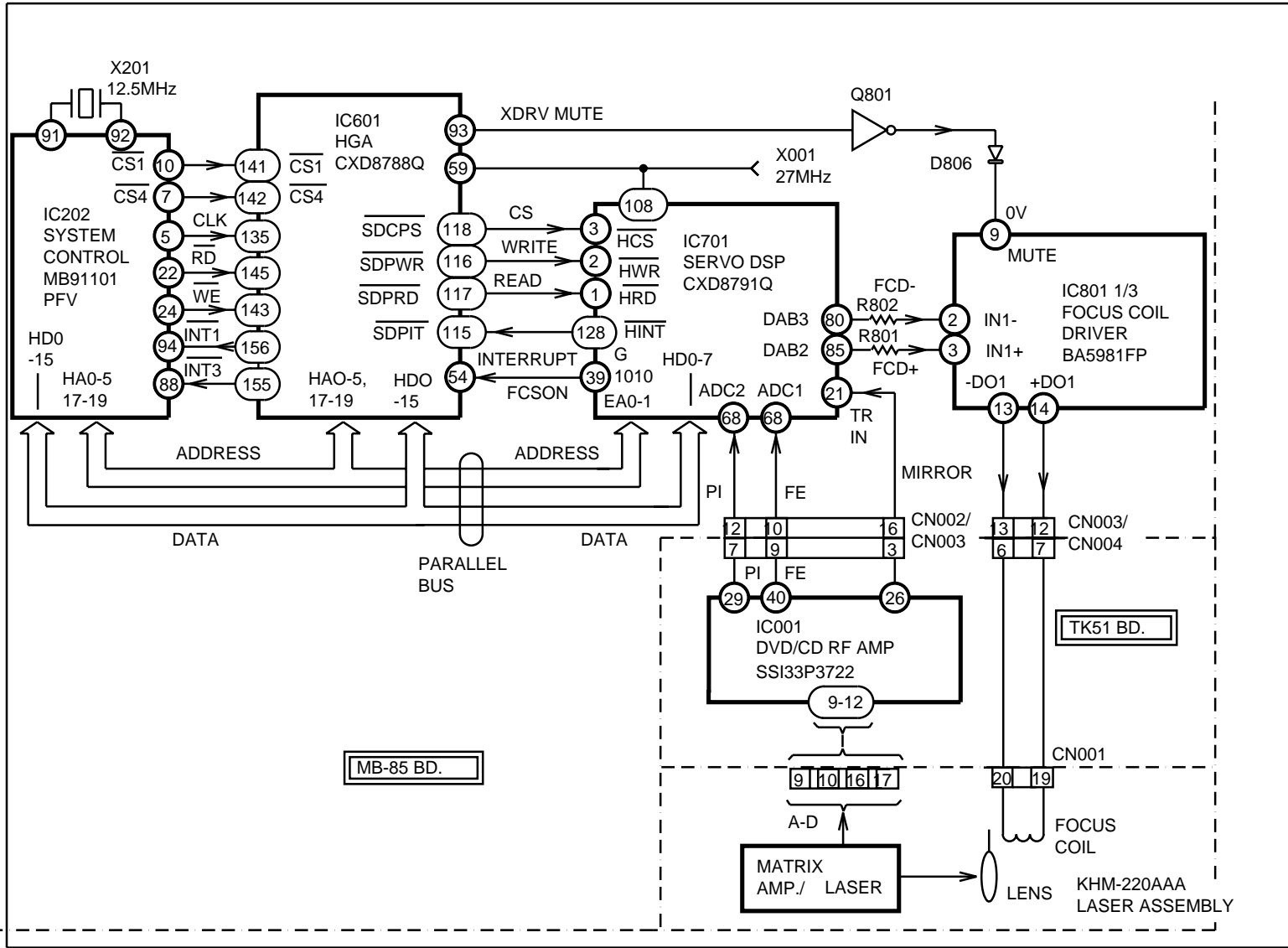

FOCUS

11DVD02 1155 6 29 99

IC202 to IC601 Communications		
Signal	Active	Signal Present when
Chip Select (CS1 or CS4)	Low	IC202 & IC205 gets Vcc
Clock IC202/pin 5	Low	IC202 gets B+
Write IC202/pin 22	Low	IC202 & IC205 gets Vcc
Six Address lines HA 0-5		IC202 gets B+
16 Data lines HD 0-15		IC202 gets B+

When IC601 wants to send reply data to IC202, an interrupt signal is sent to IC202. When IC202 is ready, it will send chip select, clock, read pulses and address to support the data received from IC601.

IC601 to IC202 Communications		
Signal	Active	Signal Present when
Interrupt (INT1 or INT3)	Low	An operation is completed (e.g. sled moved)
Chip Select (CS1 or CS4)	Low	IC202 and IC205 gets Vcc
Clock IC202/pin 5	Low	IC202 gets B+
Read IC202/pin 24	Low	IC202 and IC205 gets Vcc
Six Address lines HA 0-5		IC202 gets B+
16 Data lines HD 0-15		IC202 gets B+

HGA IC601 to Servo IC701

Bi-directional communications between these two ICs is similar to that described for IC202 and IC601. The differences are in the IC pin numbers and that IC601-IC701 communications are only taking place when a servo command is changed.

IC601 to IC701 Communications		
Signal	Active	Signal Present when
Chip Select (SDCPS IC601/pin 118)	Low	Power on/off, Tray in/out, disc playback
Clock Input IC701/pin 108	Low	3.3V is present
Write (SDPWR IC601/pin 116)	Low	Power on/off, Tray in/out, disc playback
Two Address lines HA 0-1		IC202 gets Vcc
8 Data lines HD 0-7		IC202 gets Vcc

IC701 to IC601 Communications		
Signal	Active	Signal Present when
Interrupt (HINT from IC701/pin 128)	Low	An operation is completed (e.g. sled moved)
Chip Select (SDCPS from IC601/pin 118)	Low	Power on/off, Tray in/out, disc playback
Clock Input IC701/pin 108	Low	3.3V is present
Read from IC601/pin 117	Low	Power on/off, Tray in/out, disc playback
Two Address lines HA 0-1		IC202 gets Vcc
8 Data lines HD 0-7		IC202 gets Vcc

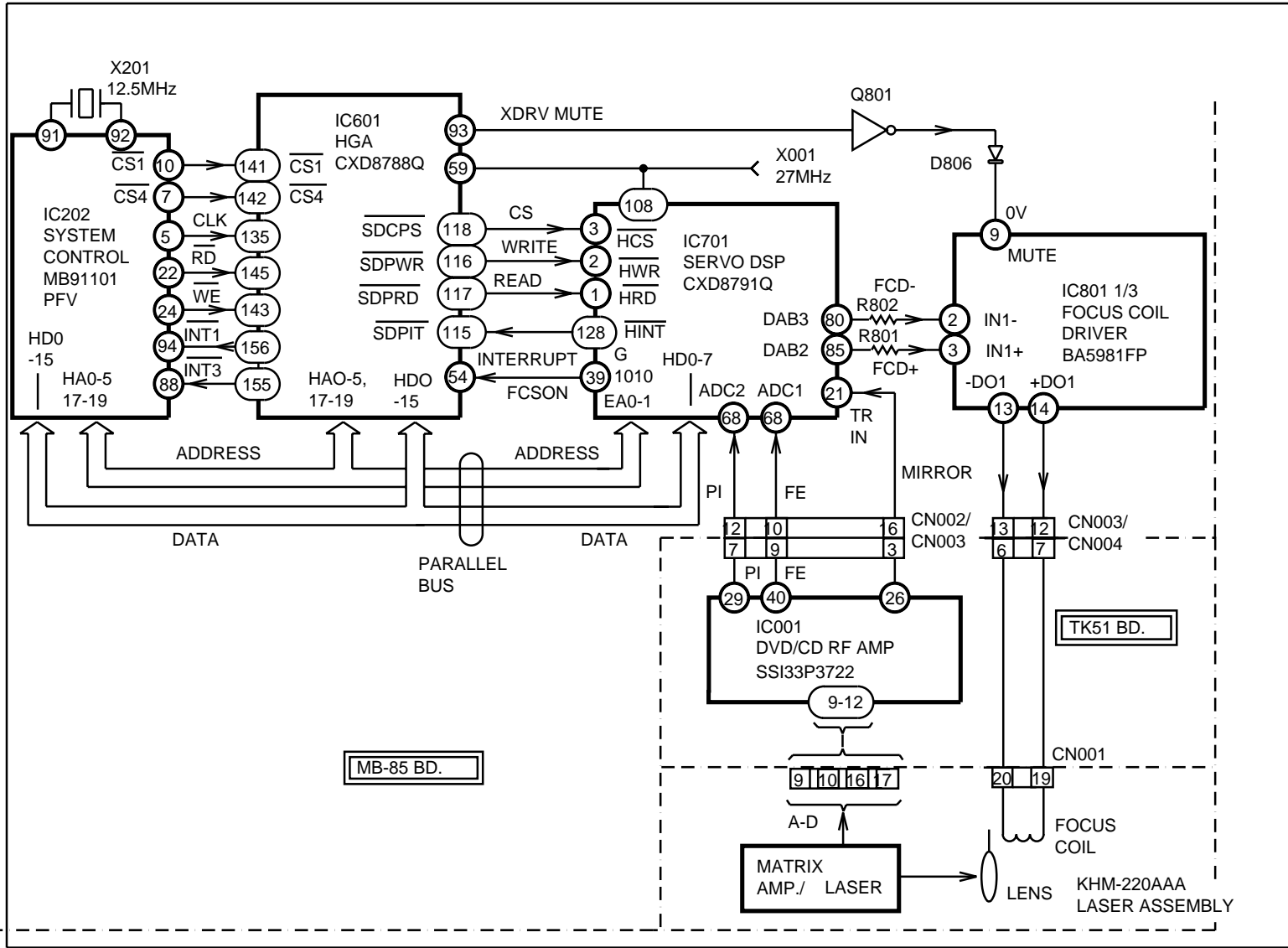

FOCUS

Spindle Motor

The spindle motor has a “kick” mode and a run mode. The kick mode is used to start and stop the motor, bringing the motor up to speed or to a stop quickly. The CLV PB mode utilizes the pits on the disc surface to regulate the spindle motor speed.

Kick Mode

IC202 issues the kick command to start or stop the spindle motor. Afterwards, all of the ICs in the Spindle Motor diagram are used in the kick mode except for IC001.

IC202

In the start program, System Control IC202 kicks (starts) the spindle motor after focus is found (or after the optical assembly sleds to home position without a disc). This kick command is written to IC601 using:

- Chip select CS4 from IC202/pin 7 (low going)
- Clock from IC202/pin 5
- Write from IC202/pin 24 (low going)
- Address and Data on the parallel bus

IC601

Gate Array IC601 transfers this kick command to ARP2 IC303 using similar communications:

- Chip select CS4 from IC601/pin 111 (low going)
- Common bit clock from PLL IC001/pin 1
- Write from IC601/pin 109 (low going)
- Address and Data on the parallel bus

IC303

ARP2 IC303 produces pulses at pins 49 and 52 to control the spindle motor. These motor drive speed (MDSO) and motor drive phase (MDPO) outputs are tri state voltages, combined by R820 and R822 to current drive IC802.

Tri State Voltages from IC303/pins 49 or/and 52	
Output	Spindle motor Direction
Open Circuit (1.6V external bias)	No rotation
3.3V (pulse)	Forward
0V (pulse)	Slows down

During start, both outputs at IC303/pins 49 and 52 are at 3.3V to bring the motor up to approximate data speed.

IC802

Spindle motor Driver IC802 takes the combined speed and phase voltages input pin 26 and amplifies them. The differential DC voltage output from IC802/pins 15 and 16 are applied to the spindle motor for rotation. The higher the voltage, the faster the spindle motor rotates.

Spindle Motor Voltage		
	CD	DVD
Start/Stop (kick)	5V (approx.)	6.3V (approx.)
Disc Inside PB	1.6V	2.8V
Disc Outside PB	0.98	1.5V

IC803

FG amplifier IC803 outputs a signal during a sudden spindle motor speed change. This start/stop conformation signal is returned to IC202 via IC701 and IC601 as a completion of the issued command.

IC701 and IC601

The comparators in Servo IC701 use the voltage change at pin 65 to determine when the spindle motor has started or stopped. This is because IC303 in the kick chain is multi tasking and will be busy at start up. IC701's kick confirmation signal is sent to IC601, which transfers it to System Control IC202. IC202 issues a kick stop signal after a fixed time. The kick time duration depends upon the disc type detected. A DVD is spun faster and consequently is kicked longer. After the kick mode, a new command is issued to start the spindle motor servo in the run mode.

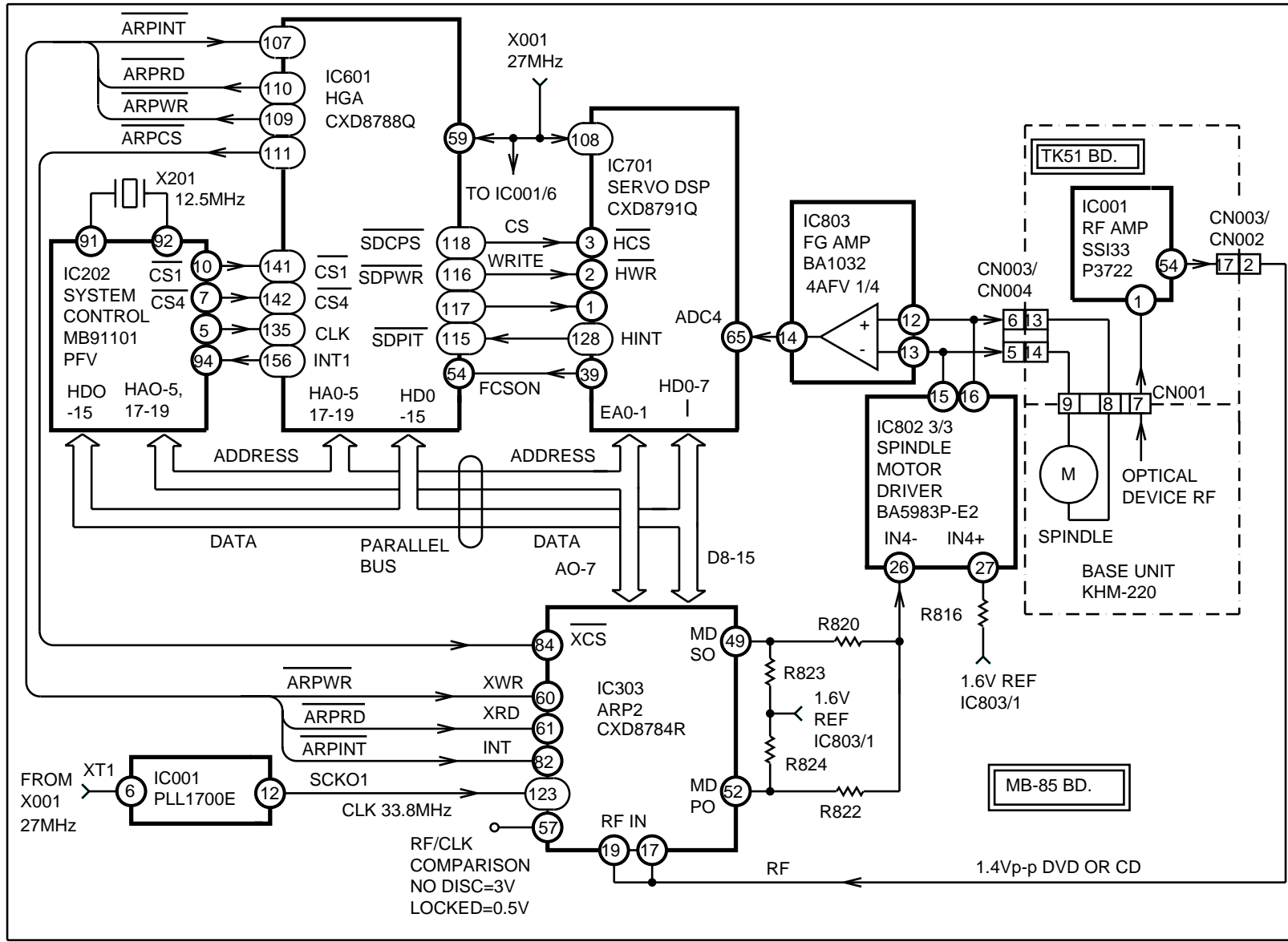

SPINDLE MOTOR

12DVD02 1153

6 29 99

CLV PB Mode

In the CLV PB mode, IC001, IC303 and IC802 are used to regulate the spindle motor speed. System Control IC202 issues a CLV run command to IC303. By this time, the disc has reached data output speed so IC303 can use the data to govern the spindle motor. RF output from IC001/pin 54 is processed by IC303. IC303 compares the RF input to internal CD or DVD references and produces MDS and MDP spindle motor correction pulses. The correction pulses vary the speed of the motor so the RF disc data is always output at a constant rate. This is called constant linear velocity.

The following waveform taken during DVD playback shows that the MDP (ch 2) signals are periodic pulses that keep the disc spinning forward. The MDS (ch 1) pulses provide incremental speed correction in the form of 3V or 0 V pulses to speed up or slow down the motor. The combined MDP + MDS voltage at IC802/pin 26 is shown in channel 3. The feedback signal (ch 4) is only present during a drastic spindle motor speed change, so it remains at 3V during DVD playback.

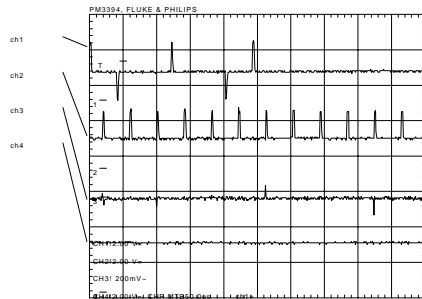

Motor Drive Signals			
	Name	Location	Voltage/div.
Channel 1	MDS	IC303/pin 49	2Vp-p
Channel 2	MDP	IC303/pin 52	2Vp-p
Channel 3	Composite drive	IC802/pin 26	0.2Vp-p (AC coupled)
Channel 4	Feedback	IC701/pin 65	2Vp-p
Time base	50usec/div.		

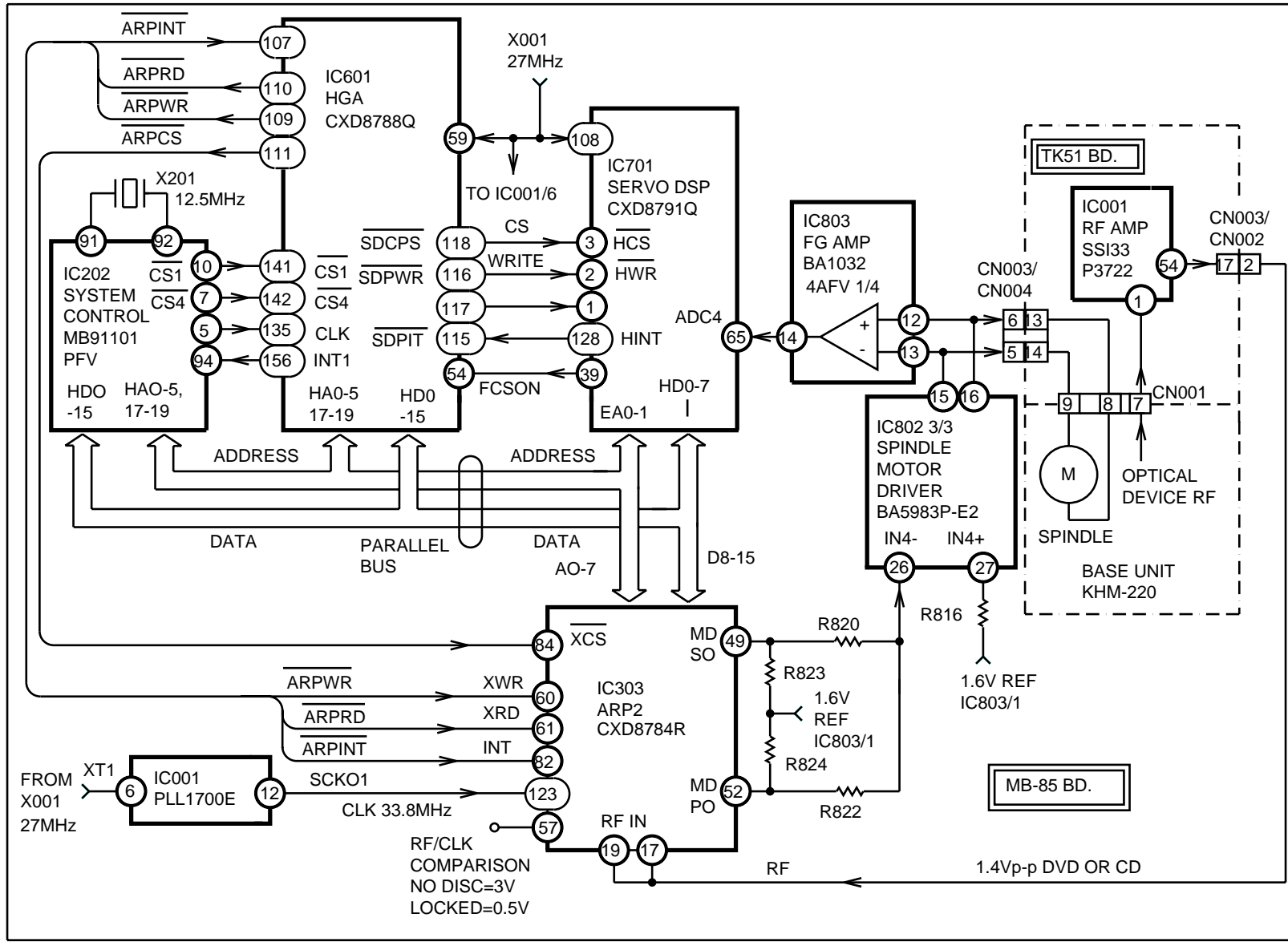

SPINDLE MOTOR

12DVD02 1153

6 29 99

Tracking Servo

The purpose of the tracking servo is to keep the laser beam positioned at the center of the disc's data (stream). This is achieved mechanically by attaching a lightweight coil of wire to the laser's objective (final) lens. This coil faces a stationary magnet. Voltage applied to the tracking coil moves the coil and its attached lens. The laser beam that passes through the center of the lens is moved with the lens from side to side.

The sources of the tracking coil signals are four detectors in the optical assembly base unit (E-H). These signals are matrixed by IC001 to make a tracking error (TE) signal. When the TE signal is connected to the tracking coil by IC701, the servo loop is complete and the servo is turned on. The laser beam is now locked to the stream of disc data.

Tracking Servo

The tracking servo in IC701 is turned on by IC202 after the second focus search while the disc is spinning. System Control IC202 must first communicate with IC601, which relays that command to Servo IC701.

System Control IC202 Uses HGA IC601

IC202 sends a tracking servo on command using data on the parallel bus. The transfer of data must be supported by additional signals from IC202:

IC202 to IC601 Communications Signals		
Signal	Active	Signal Present when
Chip Select (CS1 or CS4)	Low	IC202 and IC205 gets Vcc
Clock IC202/pin 5	Low	IC202 gets B+
Write IC202/pin 22	Low	IC202 and IC205 gets Vcc
Six Address lines HA 0-5		IC202 gets B+
16 Data lines HD 0-15		IC202 gets B+

HGA IC601 to Servo DSP IC701 Communications

IC601 controls many ICs. One of them is Servo DSP IC701. Communications between these ICs use four control lines to transfer the address and data on the parallel bus:

IC601 and IC701 Communications		
Name	From IC	When present
1. Chip Select	System Control IC202	Power on/off, playback, tray open, close and start/stop.
2. Read	System Control IC202	Always when powered on
3. Write	System Control IC202	Completion of command (PB, pause, pwr on/off)
4. Interrupt	Servo IC701	Completion of command (PB, pause, pwr on/off)
Address	Bi-directional	Always when powered on
Data	Bi-directional	Always when powered on

Servo IC701 turns on the tracking servo by completing the tracking servo loop. IC701 amplifies the tracking error signal input pin 69 and outputs it as a differential drive signal at pins 92 and 97.

Track Counting in Pause or Picture Jump

The new single DVD/CD laser still projects three light beams close together on to the disc. However, the early electronics inside the optical assembly produce new tracking detector outputs (E-H) in addition to the standard A-D RF outputs. IC001 matrixes the E-H tracking outputs to produce:

TE = tracking error signal for the playback servo

TZC = tracking zero crossing signal from IC001/pin 32 to count tracks in pause or when approaching a disc destination.

Both of these signals are applied to IC701. When the tracking servo is turned on by IC202, IC701 is instructed to amplify (and LPF) the TE signals from IC701/pin 69 and produce complementary signals at pins 92 and 97. The analog TZC signal at IC701/pin 20 is judged and sent to IC202 (via IC601) as digital track count information on the parallel bus. Driver IC801 just amplifies the input signal to drive the tracking coil.

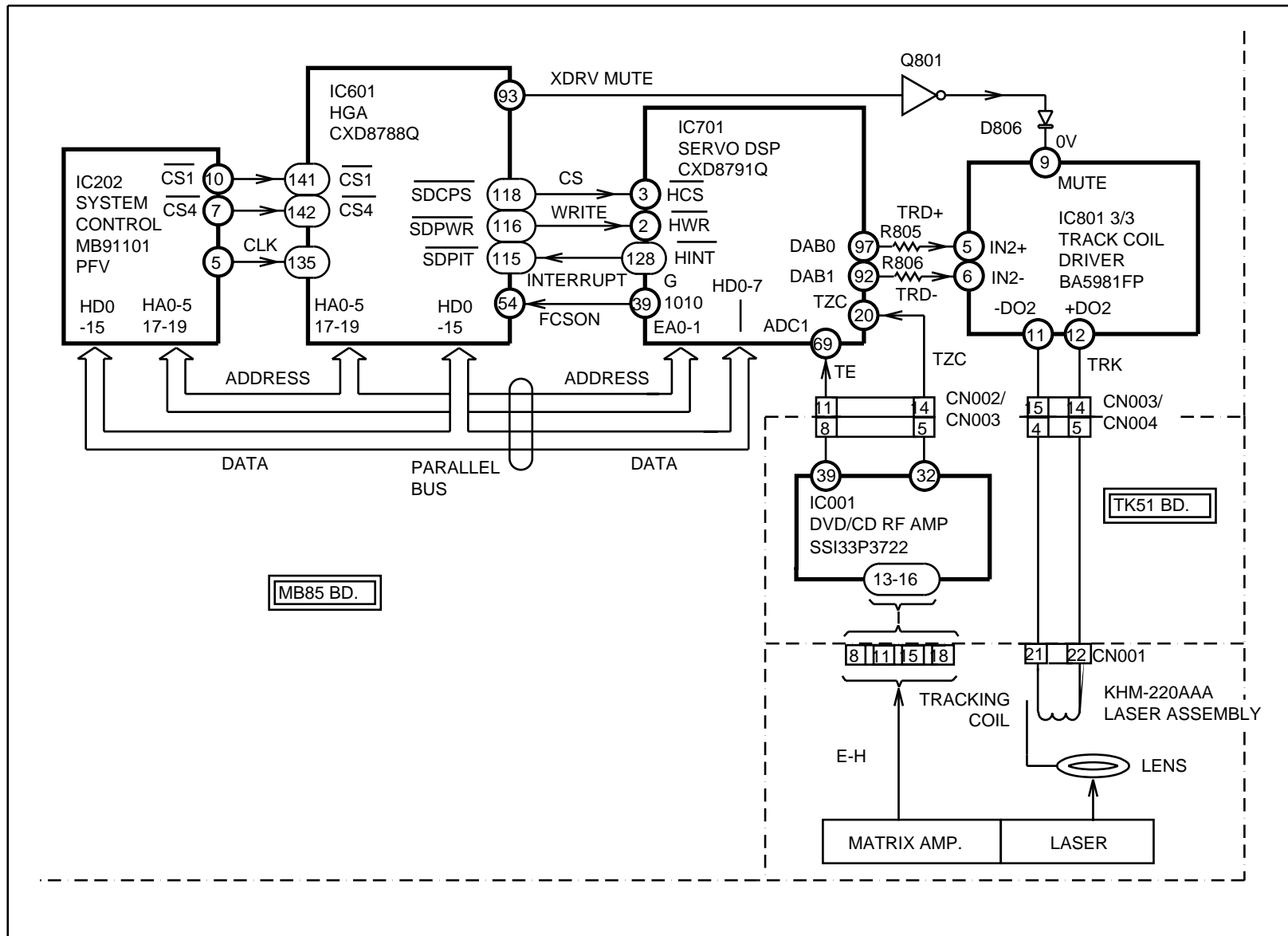

TRACKING SERVO

14DVD02 1155 6 29 99

Sled Motor Drive - PB

Initially during disc search, just System Control IC202 data was used to move the sled motor. During playback, IC202 data and tracking error are used to handle the sled movement. The choice is dependent upon the location of disc information. When the disc is played linearly requiring smooth sled travel, the tracking error signal is used to follow the track. When information must be retrieved at a different part of the disc, System Control IC202 instructs the sled to momentarily move the laser assembly to another location.

Following the Track

When playing a CD, and most of the time when playing a DVD, the sled is periodically pulsed or “kicked” ahead so the tracking coil can remain within operating range of the new disc information. These sled kick pulses originate from the linear tracking error signal taken from Tracking Coil Driver IC801/pin 6. This error signal is amplified internally and output IC801/pin 7.

The amplified tracking error signal is LPF by R707 and C705 before entering IC702/pin 3. With C706 positioned between IC702/pins 1 and 2 for negative feedback, IC702 is configured as an active LPF. These two low pass filters remove the instantaneous tracking error “noise” component. What is left is a DC voltage that increases when the tracking servo approaches its mechanical limit.

The DC component of the tracking error signal is passed onto Servo IC701/pin 66. IC701 makes a judgment about the input voltage level. When a DC threshold is reached, IC701 “kicks” or rotates the sled motor forward (laser outward) one step. The movement of the sled motor returns the laser assembly to the center range of the tracking servo. This causes the tracking error’s DC voltage component to drop below the sled movement threshold.

Sled Movement to Another Location

Supplemental information can be found in different locations on the DVD disc. When this information is called for, the sled is asked to move to approximately that location. The disc information is played to determine how close the laser is to the target. IC202 then decides to make a smaller jump or remain where it is.

This sled movement is controlled by System Control IC202 after receiving disc information from ARP2 IC303. IC202 communicates with IC701 on the parallel bus in order to have IC701 move the sled. Once the sled is moved, System Control IC202 waits for disc information (from Processor IC303) to determine if the laser is close enough to the target information before requesting another sled movement. If no sled movement is called for, the laser plays through the supplemental information. Afterwards IC202 instructs the laser to return to where it originated to resume normal playback.

IC Summary Chart

ICs involved in Sled Movement		
Disc Identification	DVD Playback	CD Playback
IC202	IC001 (TK51 Bd)	IC001 (TK51 Bd)
IC601	IC303	IC701
IC701	IC202	IC702
IC802	IC601	IC801
	IC701	IC802
	IC702	
	IC801	
	IC802	

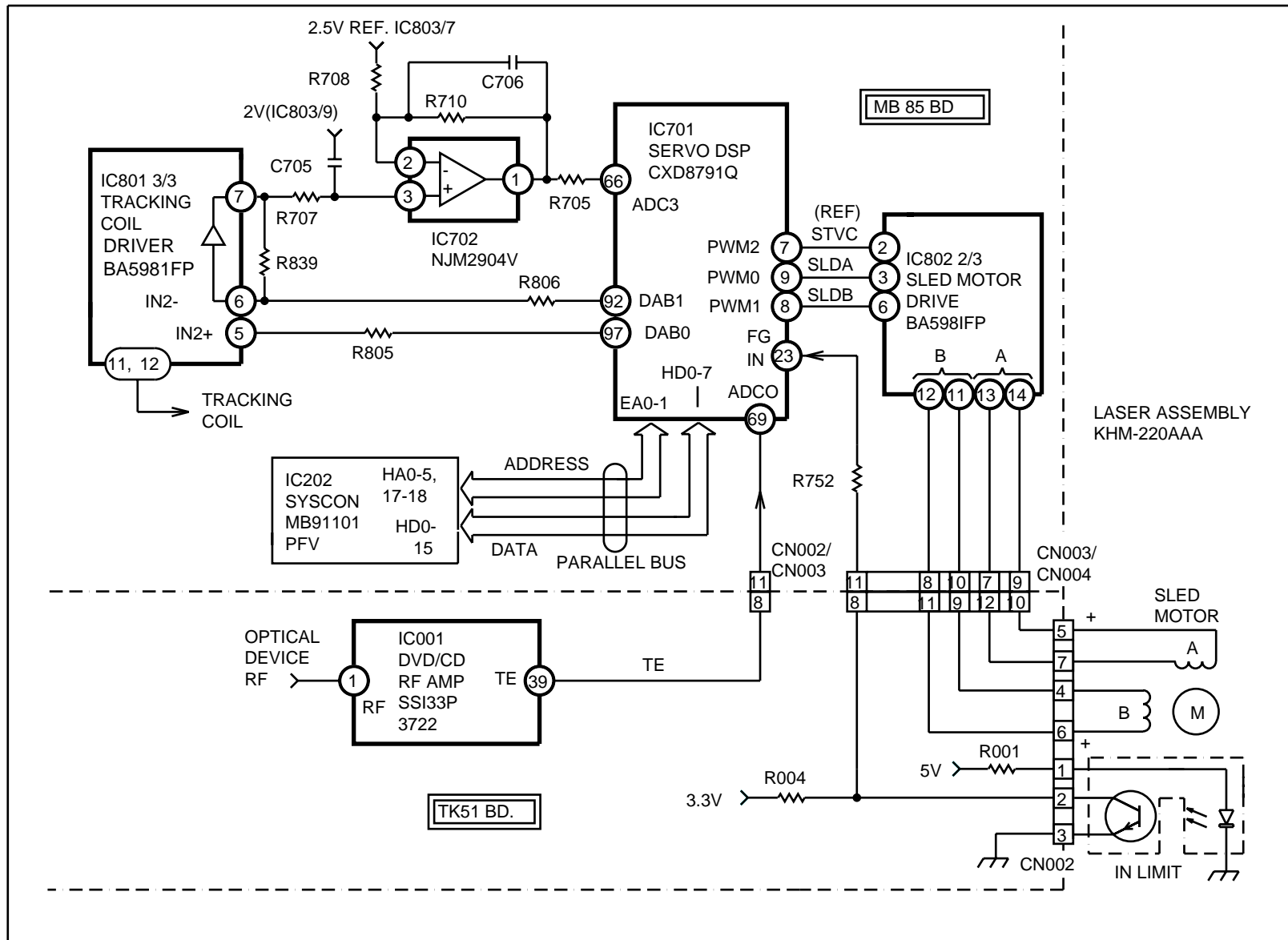

SLED MOTOR DRIVE - PB

15DVD02 1156 6 22 99

Tilt Servo

Operation

The laser is mounted on a platform that pivots at the center and rests on an incline gear at one end. The tilt motor controls the incline gear and consequently the angle of the laser beam with respect to the disc. The tilt motor is operational at:

- Power ON – the laser platform is reset to mid position
- DVD Playback-the platform is moved when the RF level fluctuates
- Power OFF – the laser platform is brought to its lowest position

Power ON

At power on, the tilt motor resets the laser platform to mid position. At first the laser platform is angled up at one end, then brought to the middle using position data stored in EEPROM IC201.

Tilt UP

The tilt motor shaft has a gear that mates with the incline gear. The incline gear has mechanical stops at each end, which establishes upper and lower limits to the laser platform that rests upon it. At power ON, the tilt motor is rotated for a revolution of the incline gear (from one stop to the other). At this point the platform is fully elevated and IC202 is aware the platform is at this position.

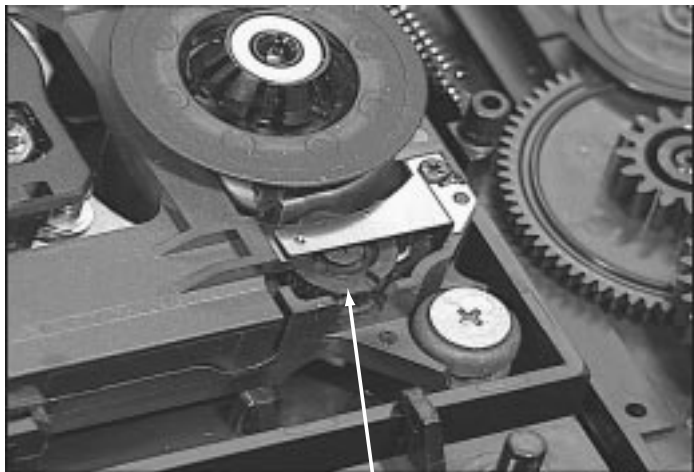

Incline Gear

Tilt to Mid Position

The tilt motor is a stepping motor. Each time the stepping motor is pulsed, it moves the incline gear and corresponding laser assembly a known amount. Consequently, IC202 can pulse the motor a given number of times to reset the laser platform to mid position. At mid position, the laser beam is perpendicular to the disc.

ICs Involved

Five ICs are used to perform this reset function:

- System Control IC202
- EEPROM IC201
- Hybrid Gate Array IC601
- Servo DSP IC701
- Motor Driver IC801

At power on after initial communications, IC202 retrieves the servo mechanism reset data from EEPROM IC201. IC202 issues the tilt motor turn command to IC601 when it is chip selected (CS4 = low into IC601/pin 142). That information is transferred from IC601 to Servo IC701 at a different time using a different chip select line (HCS at IC701/pin 3).

Servo IC701 interprets this input data and produces stepping pulses to drive the tilt motor. The stepping pulses are out of phase to rotate the motor in one direction.

The following waveforms show three tilt drive down pulses generated from the servo control test mode. The TLTA signal appears before TLTB, causing the tilt motor to rotate toward coil B (laser platform down). These signals (ch 1 and 2) that are input to the tilt motor driver IC801 are compared to the drive output (ch 3 and 4). They show that only the TLTA input signal corresponds to the ITA outputs to the tilt motor A coil.

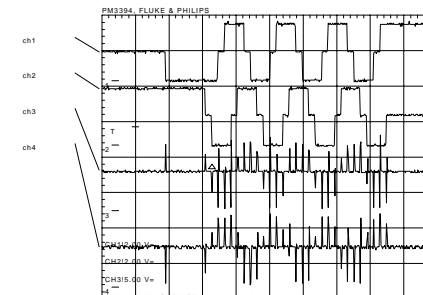

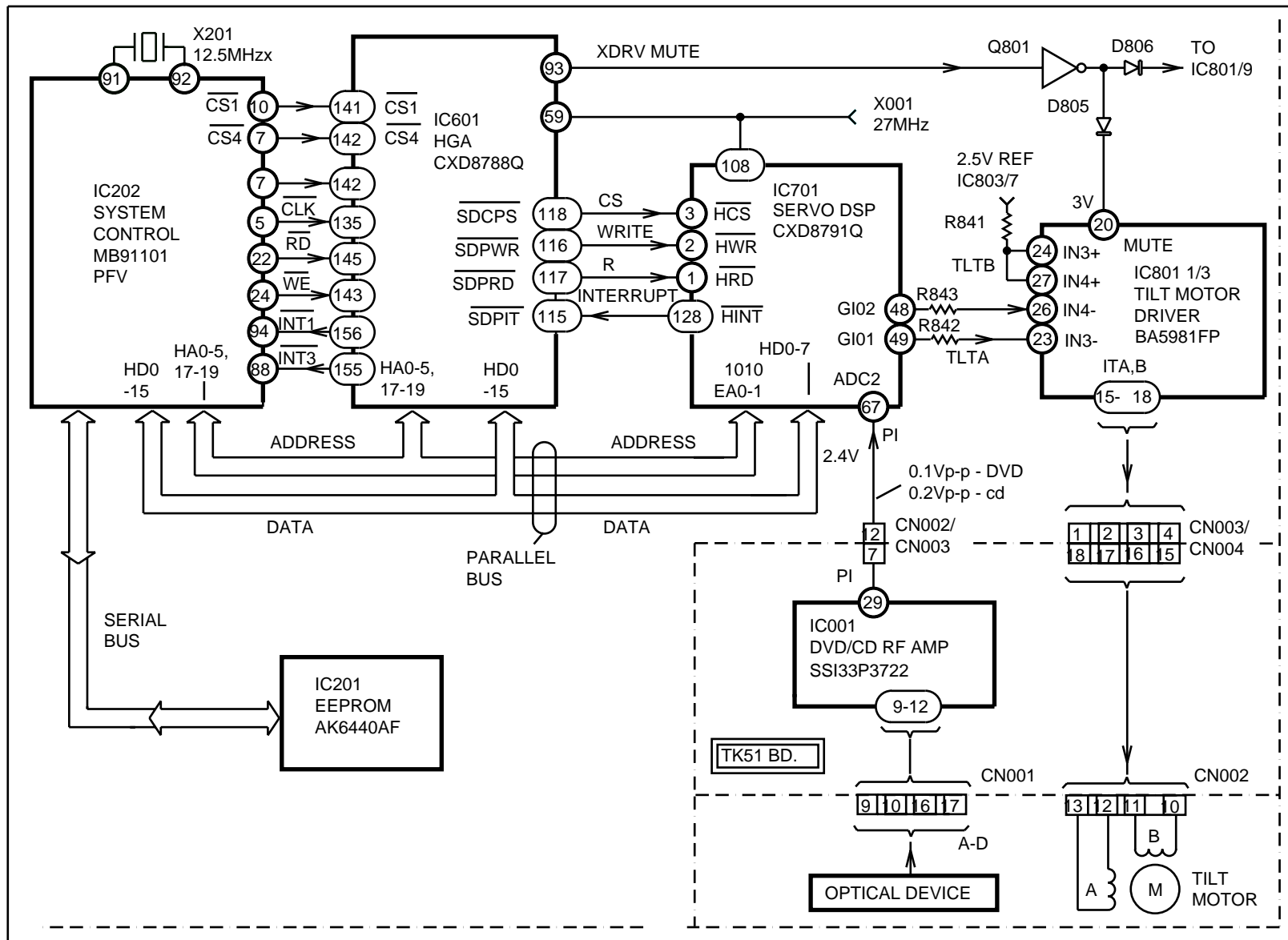

TILT SERVO

10DVD02 1151 6 22 99

Tilt Drive– Test Mode Tilt Down			
	Name	Location	Voltage/div
Channel 1	TLTB	IC701/pin 48	2Vp-p
Channel 2	TLTA	IC701/pin 49	2Vp-p
Channel 3	ITA -	CN003/pin 1	5Vp-p
Channel 4	ITA +	CN003/pin 2	5Vp-p
Time base	500msec/div.		

Driver IC801 supplies the current necessary to develop the magnetic fields in the motor to make it step. The tilt motor driver IC801 is inhibited (muted) from working when the tray is out when a low is placed at IC801/pin 20.

DVD Playback

Only during DVD playback, the tilt servo adjusts the angle of the laser beam to obtain minimum RF level fluctuations. The highest RF level is achieved when the laser beam is perpendicular to the horizontal layer of the disc. The tilt servo circuitry is most effective when the laser is at the outer limits of a warped DVD disc.

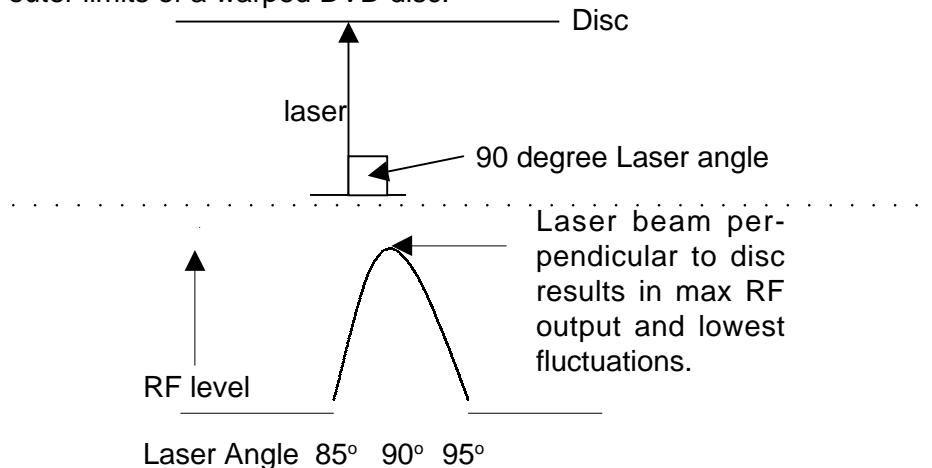

During CD playback, the incline gear remains at mid position. During DVD disc playback, the tilt servo is active. The RF eye pattern signal from IC001 is input to IC701/pin 67 and monitored by IC701. IC701 filters the RF fluctuations and delivers this information as a digital level to System Control IC202.

Delivery

First IC701/pin 128 sends an interrupt low to IC202 via IC601. When IC202 is ready to receive this information, it sends a chip select low pulse from IC601/pin 118 and a read low pulse from IC601/pin 115 so IC701 can send the low RF data information to IC601. IC601 passes this information to IC202 on the parallel bus when chip selected by IC202.

Decision to Tilt

When the RF voltage has dropped below the threshold level stored in Flash ROM IC205, IC202 instructs the tilt motor to rotate in one direction. The RF level is sampled afterwards. If it is still low, the tilt motor is rotated in the other direction and the RF voltage is sampled again. The process is repeated until the RF fluctuations have reached a minimum level.

Power OFF

At power off, the tilt motor drops the laser platform to the lowest position just before the power supply is shut off. At this laser position the incline gear is at one of the lower stop position. At the next power ON, the incline gear will be stepped to the higher stop position, bringing the laser platform to maximum before going to mid position.

Clicking Noises

If the DVD player was unplugged, the incline gear will not be returned to its lower stop position and will remain at its middle playback position. When the unit is powered ON again, the incline gear will be instructed to step a full rotation from one stop to the other.

Since the incline gear was as mid position instead of at the lower stop position, the incline gear has less to travel and will prematurely reach its mechanical stop. You will hear clocking noises as the tilt motor gears slip. To avoid these clicking noises, shut off the unit first and wait for the red standby light to come on before unplugging the set. This will allow the tilt motor to return the incline gear to its stop position.

Manually Driving the Tilt Motor

The tilt motor can be driven in either direction using the unit's test mode. This checks the gears and communications between IC202, IC601 and IC701. It does not check the tilt motor operation during playback, which uses the RF input to IC701/pin 67.

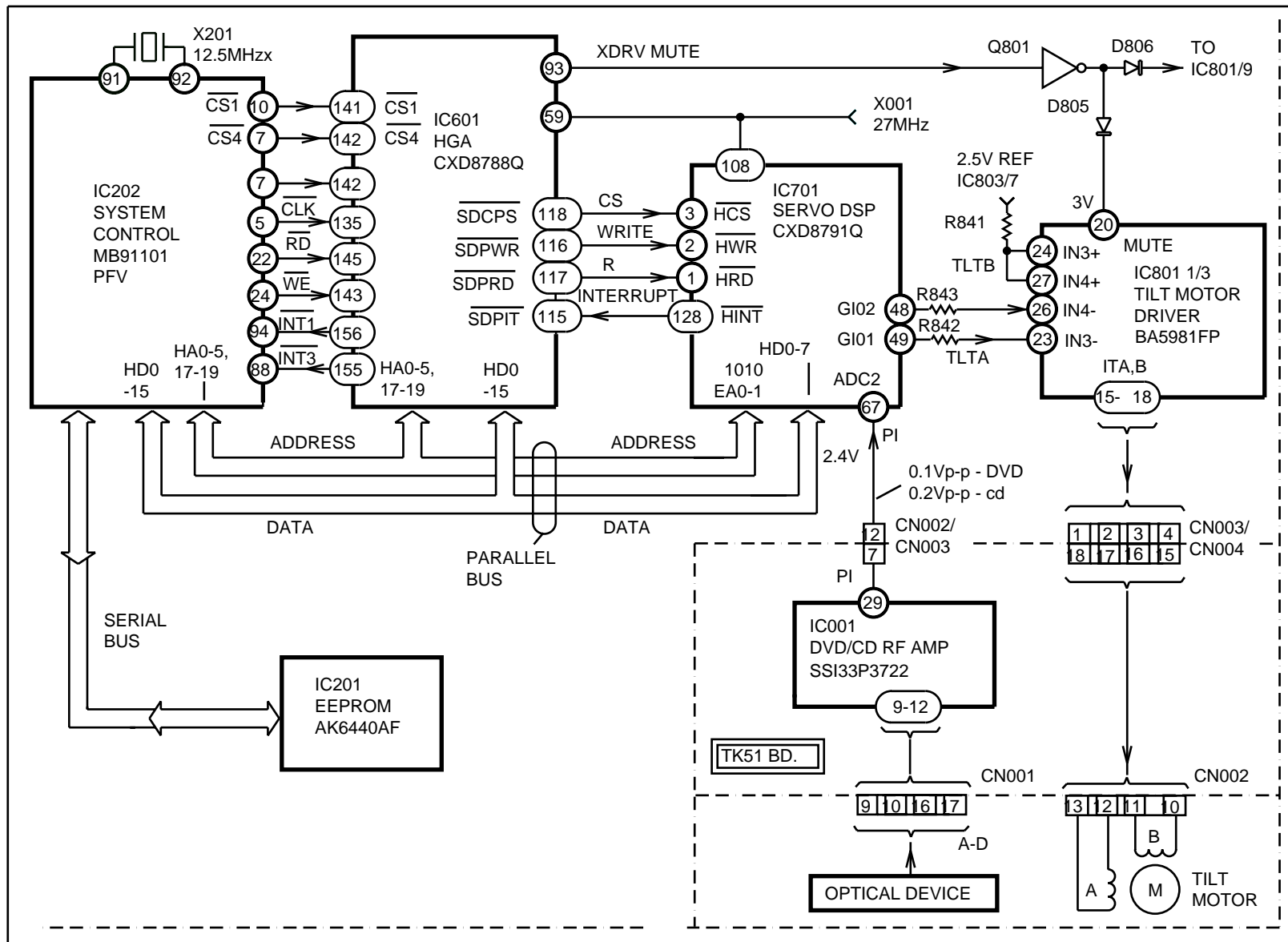

TILT SERVO

10DVD02 1151 6 22 99

Audio/Video Processing Block

The RF / eye pattern signal is processed by several blocks to recover the audio and video signal that is output the rear panel.

Optical Device

The optical device contains an active amplifier and matrix to produce a low noise RF or eye pattern signal from the A-H detector's signals. The RF and A-H detector signals are all input to the RF amplifier IC001.

RF Amplifier IC001

The RF signal is amplified when small, and limited when large, to equalize the eye pattern signal that is applied to the next A/V stage. The A-H detector signals are matrixed in the RF amplifier to produce servo signals like focus error (FE), tracking error (TE), track zero crossing (TZC) and PI and Mirror signals for disc identification. These signals go to the servo IC.

ARP2 IC303

The Advanced RF Processor (ARP2) IC303 receives the analog eye pattern data and first converts it into a digital waveform by "slicing" it across the middle. A voltage above the middle becomes a HIGH output and a voltage below becomes a LOW voltage. The HIGH and LOW voltage begin their digital journey within IC303. To support the digital signal a clock is made from the input signal.

How successful the data locks to the internal PLL to make this clock can be monitored at the JITTER pin 57 of IC303. A low voltage proves a lock. This means the servos are OK and the signal processing is OK to this point. A high voltage means the input eye pattern should be examined again. A clear (no noise) signal means the servos are OK and the disc signal is incorrect or IC303 is not able to lock onto the input signal (IC303 or its support parts are defective).

Additional signal processing within IC303 unscrambles the digital data and channels the CD and DVD data into separate output ports. Both outputs are fed to separate A/V Decoder IC401 inputs.

A/V Decoder IC401

The CD and DVD input signals undergo separate processing. The CD audio is virtually untouched and leaves the IC in the audio processing path to IC501.

The DVD video signal is MPEG decompressed using two external SDRAM ICs (not shown) for momentary storage during the processing. The subpicture (subtitle and DVD disc menu) pieces of data are loaded into memory and when called for, added into the main picture. The digital information is returned to analog form by the internal D/A converter. The DVD player's menu is added as an on screen display (OSD) just before the analog video leaves IC401.

The DVD audio signal is also MPEG decompressed and the PCM is extracted to take the route out of IC401 through IC501 and IC902 for the analog audio processing. Dolby digital AC-3 decompression takes place in this IC401 using the two external SDRAMs (not shown) that are also used for video decompression. IC401 first recognizes the 5.1 channel AC-3 or DTS data and informs Syscon IC202.

Audio DSP IC501

IC501 Audio Processing		
CD	DVD	DVD with AC-3
Rear channel delay (Digital Cinema Sound / VES)	Rear channel delay (Digital Cinema Sound / VES)	Pass through of the 5.1 channel AC-3 signal
Dolby Prologic Decoding	Dolby Prologic Decoding	Downmixing of 5.1 channel AC-3 to 2 channels.
Dolby Surround	Adds DTS flag to the digital output	Signal balancing
		Test tone generation

The outputs are digital signals to the rear panel coax and optical ports and digital signals to the D/A converters IC902, IC905-7.

D/A Converters

IC902 receives the digital signals for the analog L/R channels. The remainder of the converters, IC905-7, is used for the 5.1 channel digital conversion to analog signals.

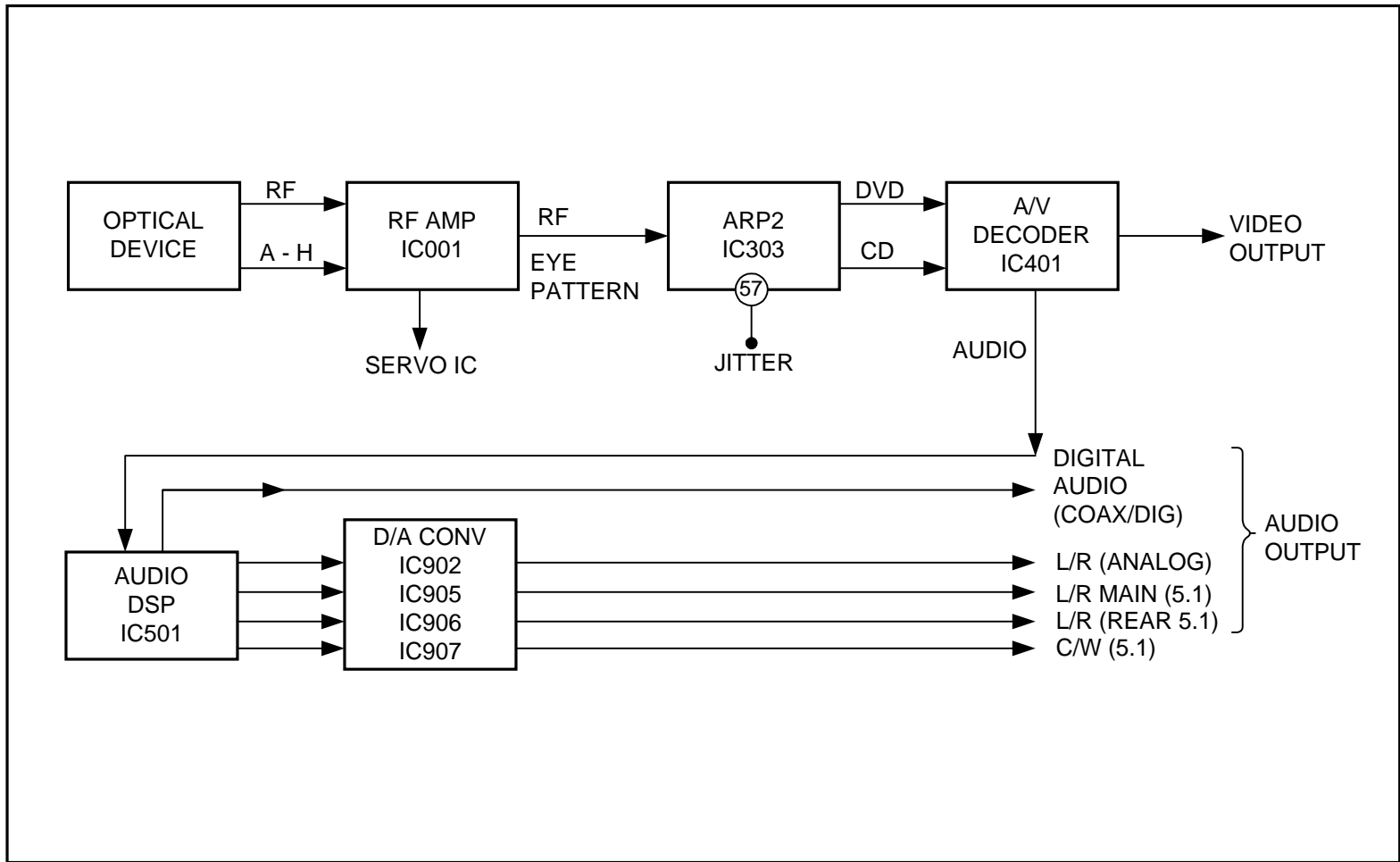

A/V PROCESS BLOCKS

28DVD02 6 22 99

A/V Processing

There are three major ICs in the combined A/V processing chain; two buffers in the following video chain and nine ICs in the final audio chain:

A/V Processing ICs		
Combined A/V	Video	Audio
RF Amp IC001	Video Buffers IC303	DSP IC501
ARP2 IC303	Video Buffers IC321	2Ch D/A Conv. IC902
A/V Decoder		Front Ch D/A Conv. IC902
		Rear Ch D/A Conv. IC902
		Center/Woofers D/A Converter IC907
		Amplifiers IC431, IC502, IC541 and IC571

Once the servos begin operation, there is RF output from the optical device in the base unit. These ICs process the RF output:

RF Amp IC001

Purpose:

Amplifies and matrixes the A-D input signals from the optical assembly to produce RF, FE, PI outputs. Matrixes the E-H input signals to produce TE (and TZC).

Outputs:

- RF signal for A/V and spindle motor processing
- FE, TE, PI signals for servo control

ARP2 IC303

Purpose:

- Asymmetrical correction – Active circuit for AC coupling the input RF signal. Shapes sine input signal into a square wave.
- Sync clock extraction – Bit clock (PLL) made from the disc data.
- EFM and De-Interleaving – First level of descrambling the data pieces using external memory IC304 (Reed – Solomon Code).

Outputs:

DVD Output Signals from IC303			
Name	From IC	Purpose	When present
SD 0-7 disc data	IC303/pins 97, 98, 100-105.	A/V disc data	DVD PB only
XSHD	IC303/pin 93	0.25usec low going pulse to mark the beginning of the DVD data	DVD PB only
XSRQ	IC401/pin 51	Used as a busy line	DVD PB only
XSAK	IC303/pin 95	Data Acknowledgement	DVD PB only
SDCK	IC303/pin 91	Bit clock	Power on

CD Output Signals from IC303			
Name	From IC303	Purpose	When present
Data	Pin 107	CD data	Power on
D Out (data)	Pin 110	CD data	CD PB only
B Clk	Pin 108	Bit clock	Power on
L/R Clock	Pin 109	Left/right clock	Power on

The following waveforms show the two CD data outputs (Ch 1 and Ch 3) from ARP2 IC303 accompanied by the left / right clock (Ch 2).

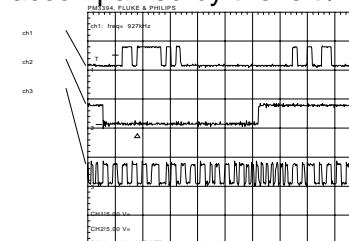

CD Data Output Waveforms – CD PB			
	Name	Location	Voltage/div
Channel 1	CD Data	IC303/pin 107	5Vp-p
Channel 2	L/R Clock	IC303/pin 109	5Vp-p
Channel 3	CD D Out (data)	IC303/pin 110	5Vp-p
Time base	2usec/div.		

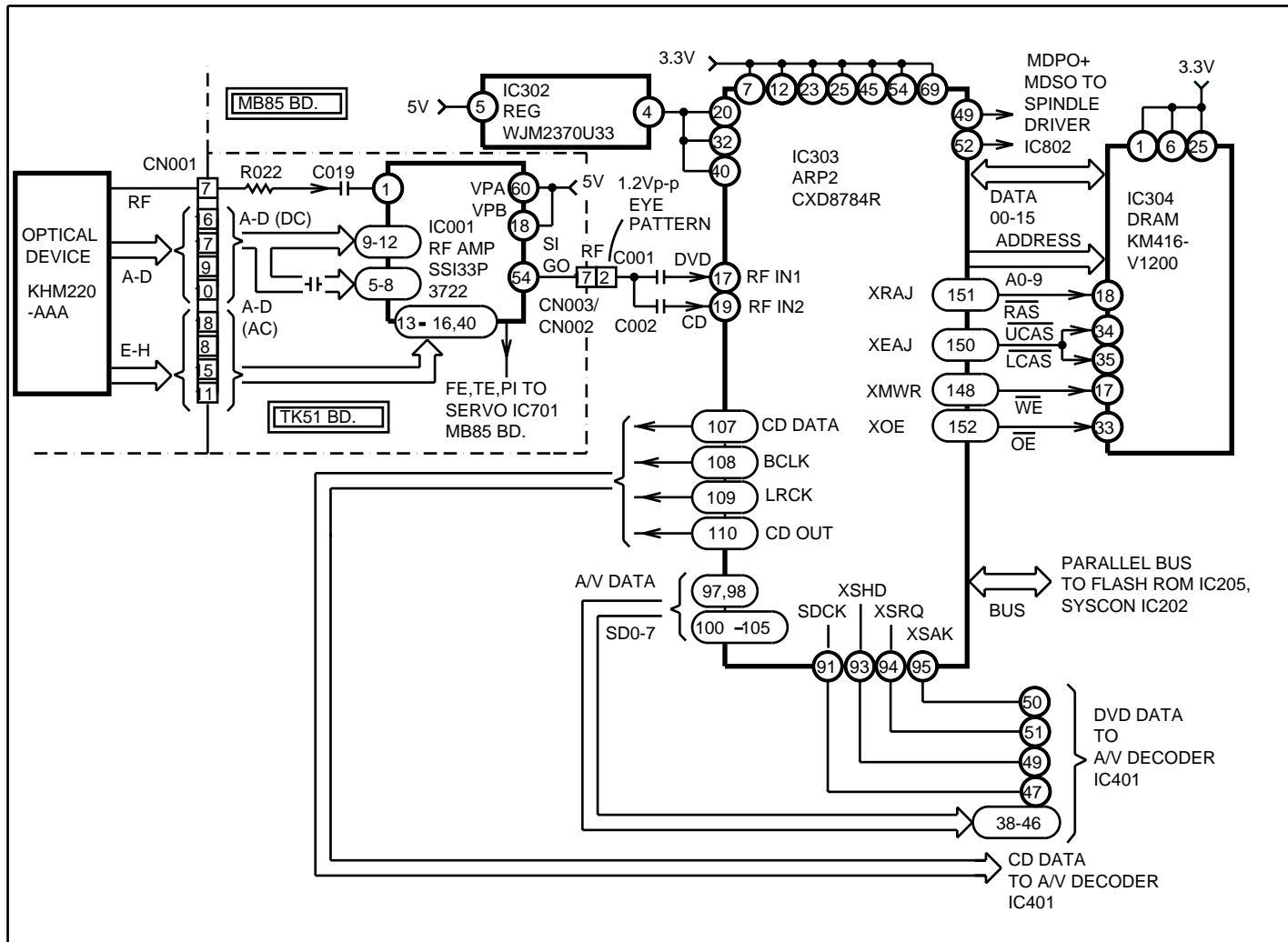

AV PROCESSING

26DVD02 1172 6 22 99

These waveforms were taken with the player turned on and no disc inserted. They show that the CD DOut data signal (ch 2) from IC303/pin 110 is fixed to half of the bit clock frequency (ch 1).

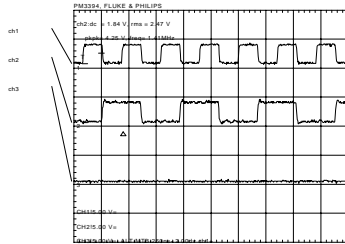

CD Output – Power ON only (no PB)			
	Name	Location	Voltage/div
Channel 1	Bit Clock	IC303/pin 108	5Vp-p
Channel 2	CD DOut (data)	IC303/pin 110	5Vp-p
Time base	0.25usec/div.		

A/V Decoder IC401

Purpose

Video

- MPEG decompression using the external IC402 and IC403 memories.
- Crops the 16x9 image for a 4x3 TV picture (software dependent).
- Communicates with IC202 with servo control changes to get info at different parts of the disc.
- On screen display graphics.
- D/A Converter (analog video output).
- Generates MacroVision copyguard signals when instructed.

Audio

- MPEG audio decompression
- Dolby Digital AC-3 decompression using external SRAM IC402 / IC403

Outputs:

- 6 Analog Video channel Outputs (Y, B-Y, R-Y, Composite, Y, C)
- 6 channels of Dolby Digital (AC-3) audio with clock signal support.

Flash ROM IC205

Contains fixed data about how this DVD player should store, retrieve and process information. SYSCON IC202 processes this information. Some of the information processed is as follows::

- Some variables in the MEPEG Video and AC-3 Audio processing
- What ICs to check during start up
- Stores the power ON DVD Sony logo
- Test mode overall operation (servo data is in IC201)
- Color bars used in the test mode (main picture)
- Menu languages and characters

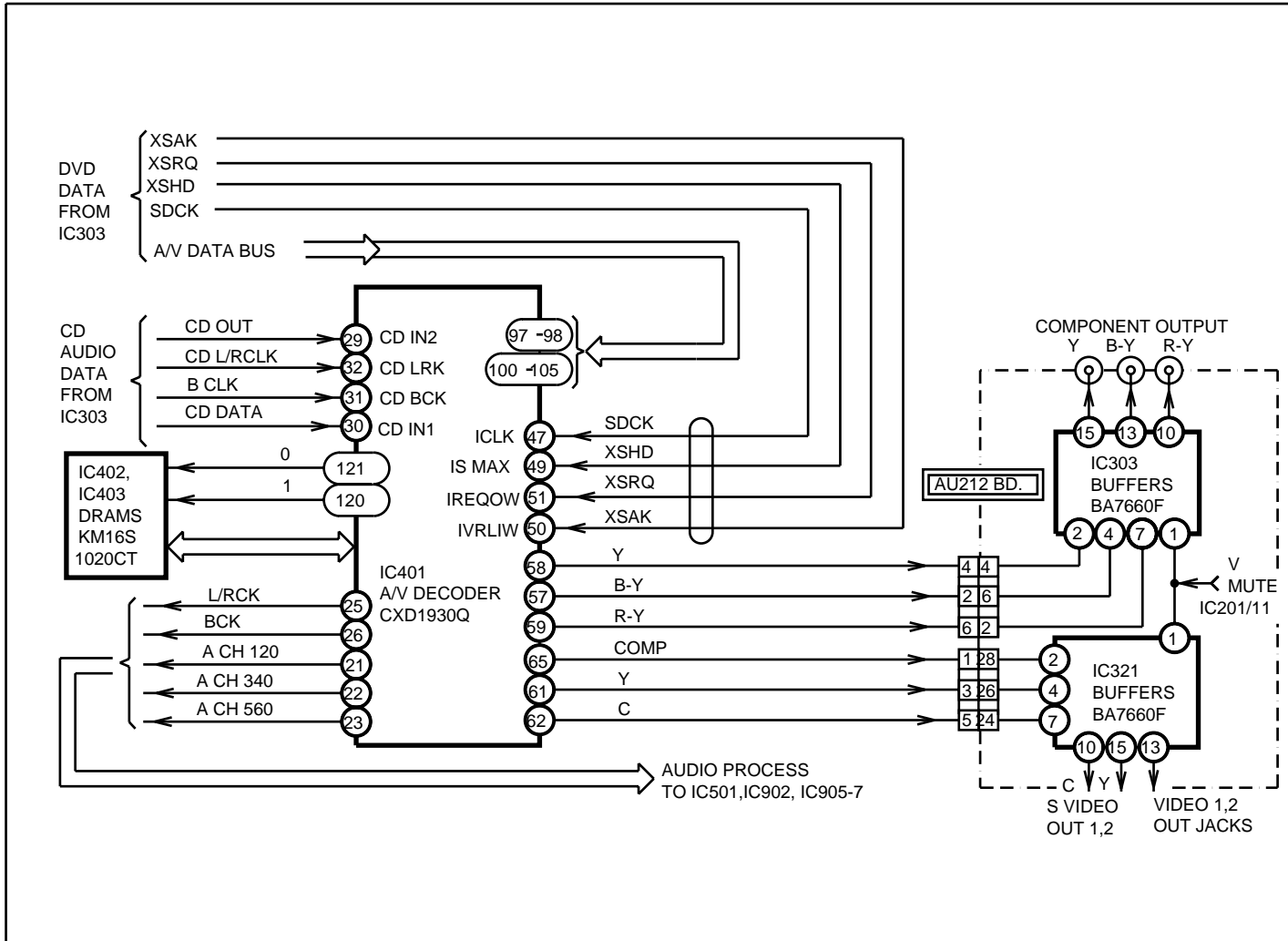

VIDEO PROCESS

27DVD02 1173 6 29 99

Audio DSP IC501

Purpose:

- Down-mixing of six channel AC-3 into two (L/R) channels
- Dolby Prologic decoding
- Audio enhancements when there is no AC-3 received (this rear channel delay circuitry is only found in some models):
- Digital Cinema Sound gives you the illusion of various spatial room environments
- Virtual Enhanced Surround (VES) for 3D sound with two speakers
- Enhanced Surround for a greater sense of presence from the normal Dolby Prologic sound
 - Digital coax and optical output
 - Rear channel delay
 - Front/rear level balancing
 - Test tone generation

Outputs:

DSP IC501 Output Signals			
Name	From IC501	Purpose	When present
L/R Clock	Pin 10	48kHz or 44.1kHz clk *	Power On
Bit Clock	Pin 9	2.3MHz or 2.1MHz clk. *	Power On
CH78O	Pin 11	Data for analog channels	Audio PB
CH12O	Pin 15	Data for 5.1 front channels	Audio PB
CH34O	Pin 14	Data for 5.1 rear channels	When AC-3 source is input
CH56O	Pin 12	Data for 5.1 center and woofer channels	When AC-3 source is input
DO	Pin 16	Digital Output	Power On

* Depending upon the last disc detected. First frequency is for DVD.

D/A Converters IC902, IC905 – IC907

Purpose

Converts the digital input to analog output when received.

Support Signals

All the D/A IC support signals go to the same pins of these ICs because they are the same number IC (CXD8799).

D/A Converter Required Signals			
Name	Location pin #	Signal	When Present
Vcc	8, 9	3.3V (not shown)	At power ON
Audio Data	2	Data 3Vp-p	During PB
L/R Clock	1	44.1kHz = CD detected 48.kHz = DVD detected 3Vp-p	At power ON
Bit Clock	3	2,116MHz = CD detected 2,304MHz = DVD detected 3Vp-p	At power ON
Master Clock (Xtal)	5	33.868MHz = CD detected 36.864MHz = DVD detected 4Vp-p	At power ON
Output	13 & 16	2Vp-p (analog audio)	During PB
Chip Select	28	10usec, 3Vp-p, low pulse.	At play, pause, stop.
Communications Clock	27	4 groups of 8 low going pulses.	During PB
Communications Data	26	20usec positive going data pulses. Data is used for reset, mute, and gain/balance. H= pause or stop.	During PB

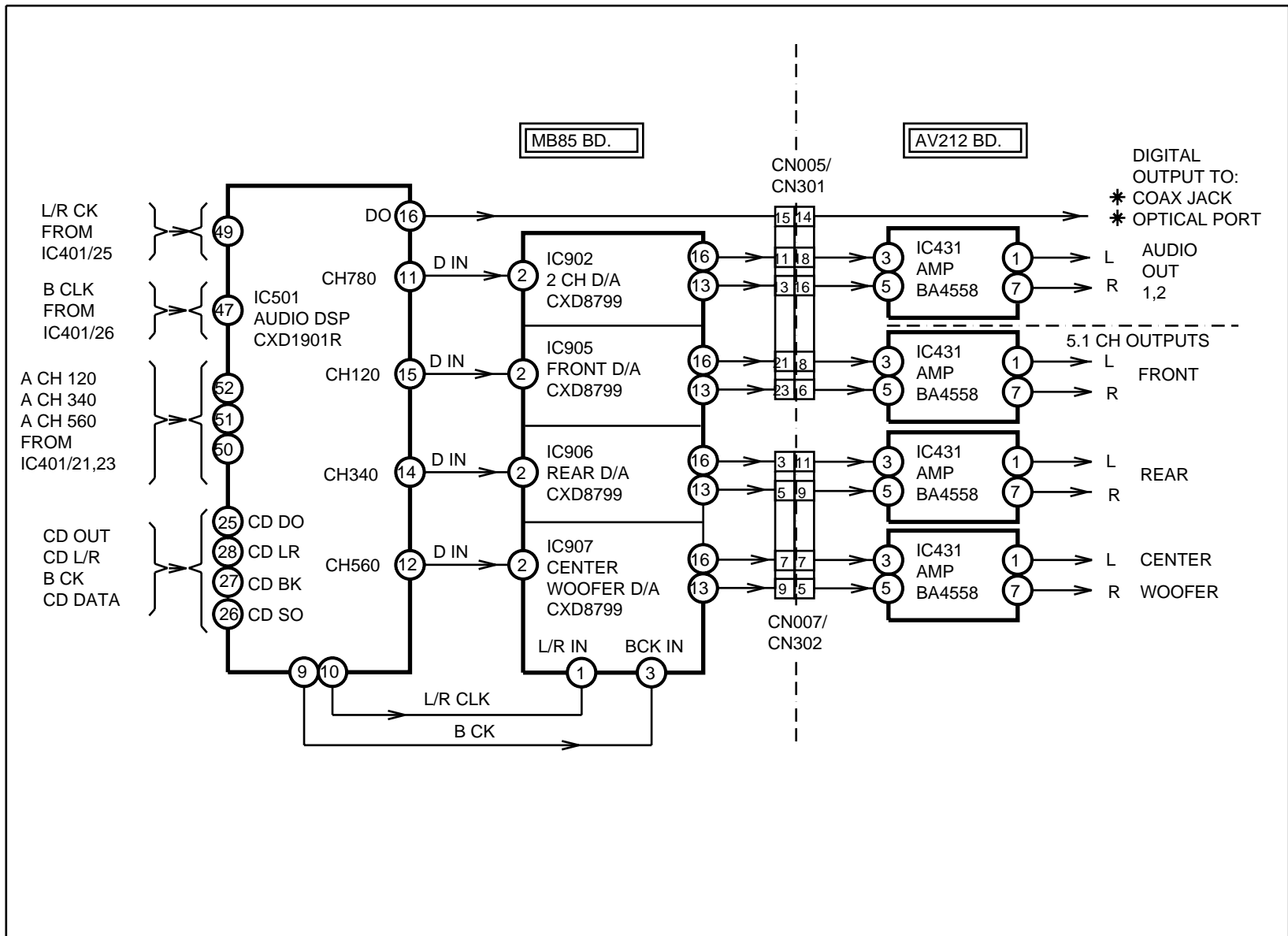

AUDIO PROCESSING

Test Mode

The test mode allows you to diagnosis problems and make adjustments using the remote commander and TV monitor. The instructions and results are given on the TV screen (OSD).

Test Mode Access

1. Plug in the DVD player,
2. Select DVD on the remote,
3. Aim the remote at the DVD player; and
4. Press the TITLE, CLEAR and POWER buttons one after another.

The red standby light changes to green and the blue Dolby Digital light will come on. The display will momentarily flash DIAG START as IC202 retrieves the program from the flash ROM IC205.

Exit

To leave the test mode, turn the power off.

Tests

The initial test mode menu shows seven options. Selecting a number enters that option level. You can navigate through each menu of that level using the remote's PREV or NEXT keys. The RETURN key brings you to the previous level.

0. Syscon Diagnosis

This is a communications test between IC202 and IC on the parallel bus and is similar to the quicker checks that occur during power ON. If the unit powers on, it will usually pass this check.

Writing information in and reading the same information checks most ICs. When the two match, the IC is deemed good. This testing occurs when the TV screen changes to a blue background. The IC is good if the original menu reappears.

In this check, the remainder of the video IC401 is tested by producing a video patterns to confirm operation. The audio IC501 is instructed to produce individual audio tones to each channel.

In checking the A/V Decoder (CDX1930 IC401), the OSD words "CHG_COLCON" mean this part of the IC is OK.

1. Drive Auto Adjustment

Automatically plays the disc and reloads new data into EEPROM IC201. This is used when memory IC201 or the optical assembly is replaced. Test discs are required for these adjustments. The Super Audio CD (SACD) procedure is in this generic test program, but this DVD player cannot play SACDs.

2. Drive Manual Adjustment

Servo adjustments stored in EEPROM IC201 can be altered manually. This operation is useful if you want to determine if the player can identify the disc type as the first step in playing the disc.

Servo Usage - Automatic Disc Identification	
Servos used	Servos NOT used
Sled moves laser outward slightly	Sled moves laser assembly to home position at Manual Adj. entry (pressing the # 2 button)
Laser	Tilt motor resets platform to mid position at Manual Adj. entry (pressing the # 2 button)
Focus	Tracking
Spindle motor kick	Spindle motor servo (lock)

Within the Manual Adjustment is a Servo Control subsection that permits you to turn on each servo separately for observation. You can also play the disc and observe an eye pattern when all servos are on (sled does not come on in PB).

3. Mechanical Aging

This mode cycles the tray in, and then momentary plays the disc for identification. The number of cycles and the disc type found is displayed on the TV screen.

4. Emergency History

This is the most valuable diagnostic information in the test mode. The last failure is recorded in EEPROM IC201 and displayed on the TV. Ten codes may all pertain to one failure that affects various parts of the DVD circuitry that is monitored. An emergency code list is found in the service manual.

0

Syscon Diagnosis ###
Check Menu

0. Quit
1. All
2. Version
3. Peripheral
4. Servo
5. Supply
6. AV Decoder
7. Video
8. Audio

1

Drive Auto Adjustment ##
Adjustment Menu

0. ALL
1. DVD-SL
2. CD
3. DVD-DL
4. SACD

Exit: RETURN

2

Drive Manual Operation ##
Operation Menu

1. Disc Type
2. Servo Control
3. Track/Layer Jump
4. Manual Adjustment
5. Auto Adjustment
6. Memory Check

0. Disc Check Memory

Exit: RETURN

TEST MODE ACCESS

With the unit in standby, press these 3 buttons on the remote at the same time:

- TITLE
- CLEAR
- POWER



Test Mode Menu

0. Syscon Diagnosis
1. Drive Auto Adjustment
2. Drive Manual Operation
3. Mecha Aging
4. Emergency History
5. Version Information
6. Video Level Adjustment

Exit: Power Key

Model: DPX1230UC
Revision: 1.500

On Screen Display

Mecha Aging

Press OPEN key

Abort: STOP key

3

EMG. History

Laser Hours	CD	0h
	DVD	2h

1. 82 05 01 06 00 61 00 00
00 00 00 00 00 00 00 00
2. 63 68 01 04 04 00 03 3F
68 00 03 00 00 FE FF 00

Select: 1 - 9 Scroll: UP/Down
(1: Last EMG.) Exit: Return

4

Version Information

IF con.	Ver. 1.000 (D6FD)
	Group 02
SYScon.	Ver. 1.500 (DOB5)
	Model 20
	Region 01
Servo DSP	Ver. 1.000

Exit: RETURN

5

Clearing Emergency Codes

- Press TITLE, then CLEAR while viewing the emergency history screen.

Clearing Laser Hours (after replacing the laser)

- Press DISPLAY, then CLEAR while viewing the emergency history screen.

6. Video Level Adjustment

RV401 on the MB85 Bd. is adjusted for 1Vp-p video output.

Additional Test Mode

There is an additional test that permits the Interface IC201 to power up the DVD unit and test the front panel display. This individual operation of the Interface IC201 is independent of the initial start up communications with Syscon IC202.

Access:

Plug in the DVD player

Press and hold the front panel keys:

RETURN

STOP

Press this remote control key:

MENU

Activity

All lights on the front panel will turn on. After a few moments, the front panel display will cycle through all the segments. You can interrupt the cycle to test an input button by just pressing the button on the front panel or remote. The button pressed will be identified on the display.

Self-Diagnostic Function (Customer Error Codes)

In the owner's manual there are two codes listed that can appear on the front panel display when there is a problem:

C13 = The disc is dirty (This really means the RF eye pattern is fluctuating or the eye pattern is below normal amplitude.

C31 = The disc is not correctly inserted. (The disc was put in upside down.)

Exx = To prevent the player from malfunctioning, the self-diagnostics has stopped the unit. Please give the xx number to your service technician.

The xx refers to the error codes listed in the (DVP-S530D) DVD service manual, on page 6-4.

NOTES

Troubleshooting

When the model DVP-S530 DVD player is first plugged in and turned on, several things occur before “NO DISC” is displayed on the front panel. One operation is performed after the next until it reaches the end of the chain. A failure will prevent it from reaching the end and often a side trip is taken to protect the unit by shutting down. Finding out where in the chain the unit has stopped will help locate the failure. Below is a general description of the start-up operations followed by problems and answers. Use the information below as a troubleshooting guide to remain on track throughout your testing.

Operations	Details found in:
1. DVD Player is plugged in and the power button is pressed.	Power Control section of the training book
2. Communications between Interface IC201 and Syscon IC202 on the serial bus.	Power Control section
3. Front panel blue Digital Dolby indicator lights.	Power Control section
4. Communications with other ICs on the parallel bus.	Parallel Data Communications section
5. SONY DVD appears on the fluorescent display.	Power Control section
6. Sensors are checked and the Transport is returned to the initial state (tray is closed, sled goes to home position).	Mechanism section
7. Sony DVD logo appears on the monitor (OSD).	See no logo problem listed below.
8. Search for a disc is initiated using the focus search operation and other servos	Use the Test Mode section in the service manual to test the Laser, Focus, Spindle and Tracking servos. Then see the problem servo section.
9. NO DISC is displayed in the fluorescent display.	Serial Data Communications / Power Control section

GENERAL PROBLEMS AND TROUBLESHOOTING GUIDE

No Power ON

1. Unplug unit and press the POWER button to discharge the power supply.
2. Watch the front panel Dolby Digital indicator while plugging the unit into AC. If there is Interface IC201 to Syscon IC202 serial communications, the blue indicator will light momentarily. See the Power Control section for details.
To check the Interface IC201 alone (without IC202), use the procedure in the test mode section of this book (last paragraphs).

3. Press the power ON button. If the unit does not remain ON, there is a loss of communication between Syscon IC202 and a slave IC or the servo IC701 failed to reset the mechanism.
Communications occur when Syscon IC202 Chip Selects several ICs, sends data and waits for an interrupt reply from each. Use the scope to look for a low interrupt reply pulse at these ICs highlighted (in bold) while repeatedly pressing the power button to reinitiate the sequence:

Request Pulses to Syscon IC202 for Service		
Interrupt pulse From	Through IC601	To
ARP2 IC303/pin 86 (Wait)	In pin 108 (arpwt) Out pin 157 (wait)	IC202/pin 19 (Ready)
A/V Decoder IC401/pin 198 (wait)	In pin 72 (avdwt) Out pin 157 (wait)	
A/V Decoder IC401/pin 196 (interrupt)	Direct	IC202/pin 95 (interrupt)
Interface IC201/pin 78 (CN006/pin 2)	In pin 22 (interrupt) Out pin 155 (Interrupt 3)	IC202/pin 88 (interrupt)
ARP2 IC303/pin 83 (Interrupt)	In pin 107 (interrupt) Out pin 156 (Interrupt 1)	IC202/pin 94 (interrupt)
Servo IC701/pin 128 (Interrupt)	In pin 107 (interrupt) Out pin 156 (Interrupt 1)	
EEProm IC201/pin 1 (busy)	In pin 25 Out pin 155 (Interrupt 3)	IC202/pin 88 (interrupt)
DSP IC501/pin 55 (Interrupt 0)	IN pin 29 Out pin 155 (Interrupt 3)	
DSP IC501/pin 56 (Interrupt 1)	IN pin 30 Out pin 155 (Interrupt 3)	

- After the brief communications above, the servo IC701 must initialize the mechanism by closing the tray and moving the sled to home position. When completed, IC701 replies to Syscon IC202. If no reply is received within approximately 2 seconds of powering ON, IC202 instructs Interface IC201 to power down (set OFF). For details, see the Mechanism section, Tray Motor Drive section and the Initial Sled Drive section of this training book.

No DVD OSD logo

The DVD initial OSD power ON logo is stored in Flash ROM IC205. This information takes the following path to become video that outputs the AU212 board:

- Flash ROM IC205 (storage)
- Syscon IC202 (extraction and processing)
- ARP2 IC303 (pass through)
- A/V Decoder IC401 (sub-picture generation)
- Video Buffers on the AU212 board

In the test mode (Syscon Diagnosis/A/V Decoder test), the A/V Decoder can generate a main picture (color bar) or a sub picture ("CHG_COLCON") from the flash ROM data. Unfortunately they take the same path as the logo, finally separating inside the A/V decoder IC401. Therefore if the logo, test bars or test sub picture does not appear, the problem may be the storage area in Flash ROM IC205. If none appear, the path from Flash ROM to A/V Decoder IC401 is broken.

No DVD PB (CD PB OK)

- Use the test mode to perform the DVD auto adjustments using the DVD test disc.
- Use the test mode to examine the OSD emergency code entries for failures. The emergency code list description is in the DVP-S330/S530/S550/S705 service manual on page 6-10E. The front panel customer code errors are preceded by a C and listed on page 6-4 of the manual.
- Use the test mode to manually play the DVD disc by activating servos 1-6 individually.
- The minimum (marginal) eye pattern amplitude is 0.8Vp-p @ CN012/pin 1. Clean lens or replace laser. Follow eye pattern into ARP2

IC303/pin 17 (1.4Vp-p) which should produce less than 0.5Vdc at IC303/pin 57 if the PLL clock is able to lock to the data. Insufficient IC303/pin 17 input level will prevent a lock and so will a defective IC303.

5. This DVD player uses the laser and focus servos to identify the DVD. One may not be working. From the test mode, manually turn on the laser and focus search servos (Drive Manual Operation/Servo Control) for observation.
 - Laser test – using a light meter measure the laser light (never look directly at the laser) and measure voltage across R006 (laser current). 1Vdc or more across R006 means the laser is at the end of life. The light measurement is quick but not a definitive test. The current measurement is better.
 - Focus search test – Scope FE (test connector CN012/pin 3) for 1.5Vp-p minimum sine wave used for disc layer ID. Scope MIRROR output at CN002/pin 16 for 3Vp-p pulses during the search. The Mirror signal is an amplified the PI signal. Both come from RF Amplifier IC001.

No DVD DL PB (other discs PB OK)

1. Perform the test mode's "Drive Auto Adjustments" using a Single, and then a Dual layer disc, to reload data into the EEPROM IC201.
2. Check the operation of the tilt circuit in the test mode by seeing if the tilt incline gear moves manually (Test mode/Drive Manual Operation/Manual Adj/Tilt Position).
3. A single layer DVD Eye pattern's minimum level is 0.8Vp-p at the MB-85 board test connector CN012/pin 1. The laser level is affected by dirt/oil in the lens and the tilt circuit. A new laser will output approximately 1.2Vp-p.

No Disc PB

1. Use the test mode to perform the CD auto adjustments.
2. Use the test mode to examine the emergency code entry for failures.
3. Use the test mode to manually PB the CD disc by activating servos 1-6 individually to see if one is faulty.
4. The minimum (marginal) eye pattern amplitude is .8Vp-p @ CN012/pin 1. Clean lens or replace laser. Follow eye pattern into ARP2 IC303/pin 19 (1.4Vp-p) which should produce less than 0.6Vdc at

IC303/pin 57 if PLL clock is locked (3V= no lock, 0V = defective IC or external short).

6. This DVD player uses the laser and focus servos to identify the CD. One servo may not be working properly. From the test mode, manually turn on the laser and focus search servos (Drive Manual Operation/Servo Control) for observation.
 - Laser test – Using a light meter, measure the laser light (never look directly at the laser) and measure the voltage across R006 (laser current). 1Vdc or more across R006 means the laser is at the end of its life. The light measurement is quick, but is not a definitive test. The current measurement is better.
 - Focus search test – Scope FE (test connector CN012/pin 3) for 1.5Vp-p minimum sine wave used for disc layer ID. Scope MIRROR output at CN002/pin 16 for 3Vp-p pulses during the search. The Mirror signal is an amplified the PI signal. Both come from RF Amplifier IC001.

SONY

SEL Service Company
A Division of Sony Electronics Inc.
1 Sony Drive
Park Ridge, New Jersey 07656

DVD020699

Printed in U.S.A.