

**Coramex, S.A.**

---

**Corix<sup>®</sup> PRO 70 DIGITAL**

---

**Installation & User's Manual**

Release 1.1 January 2010

<b>CONTENTS</b>	<b>Section</b>
1. Introduction .....	1.0
2. Safety Information .....	2.0
Warnings .....	2.1
3. Description .....	3.0
Identification Labels .....	3.1
Equipment Parts .....	3.2
Configurations .....	3.3
4. Technical Features .....	4.0
5. Pre-Installation .....	5.0
6. Electrical Features .....	5.1
7. Installation .....	6.0
Corix PRO 70 - WM (Wall Mount) .....	6.2
Installation of options for Wall Mount model .....	6.3
Corix PRO 70 - MM (Mobile Stand) .....	6.4
Corix PRO 70 - PS (Portable Stand) .....	6.5
Folding and Extension Arm assembly (Wall Mount).....	6.6
Folding Arm assembly (Mobile Stand) .....	6.7
Folding Arm assembly (Portable Stand) .....	6.8
Tubehead assembly .....	7.0
Electrical connections to the Control Panel .....	8.0
Optional wiring to the Control Panel .....	8.3
8. Final functioning tests .....	8.4
9. Control Panel operating instructions and system operation.....	9.0
10. Protection against radiation .....	10.0
11. Checks and corrections of possible faults in dental radiography.....	11.0
12. Maintenance .....	12.0
13. Environmental risks and disposal .....	13.0
14. Drawings and Electrical Schemes.....	14.0

## **1.0 INTRODUCTION**

Corix PRO 70, manufactured by Coramex S.A., performs high quality intra-oral radiographs, ensured by the repeatability of examination combined with reduced exposure times and a small focal spot.

Corix PRO 70 has a new Control Panel with a graphic LCD display, with an array of flexible sub-menu options and an easy pre-set exposure timer.

*This manual is intended to assist the user and installer in the safe and efficient operation and installation of the equipment described.*

## **2.0 SAFETY INFORMATION**

*This manual provides all the necessary information for the correct handling of the equipment as well as warnings related to risks associated to X-ray generators.*

Coramex S.A. shall not be responsible for:

- Any use of the equipment different from what it has been designed for.
- Any damage to the equipment, the operator or the patient caused by incorrect installation and maintenance not compliant with the procedures contained in the relevant user's and installation manuals, or by incorrect operation techniques.
- Any mechanical and/or electrical changes caused during or after installation, different from those reported in this manual.
- Any expenses related to the eventual disposal of the equipment or parts.

### **2.1 Warnings**

The equipment must be used in compliance with the procedures contained in the present manual and shall never be used for purposes other than those it was designed for.

Only qualified service personnel are allowed to perform technical interventions on the equipment and to remove the tubehead from its support and access the internal components. There is risk of injury if proper procedures are not followed.

The user bears legal responsibility related to the possession, installation and use of the equipment.

Corix PRO 70 is a veterinary dental imaging device and must be used only under the supervision of qualified staff with knowledge in the field of protection against radiation.

To protect the patient from X-ray, radiation protection accessories, such as standard leaded shields must be used.

The Tubehead cover or the relevant Beam Centering Device should not be touched during X-ray emission.

No objects (i.e., lead aprons) should be hung from the extension arms.

The film or the digital sensor must be introduced in the patient's mouth either manually or by means of the relevant holders. It must never be held by the operator.

Parts of the equipment that may be in contact with the patient must be regularly cleaned following the instruction provided in this manual.

The equipment is not designed to be used in the presence of flammable anesthetics, oxygen or nitrous oxide.

Before performing any maintenance intervention, the equipment must be disconnected from the input line voltage by means of the relevant circuit breaker.

### 3.0 DESCRIPTION

#### 3.1 Identification labels

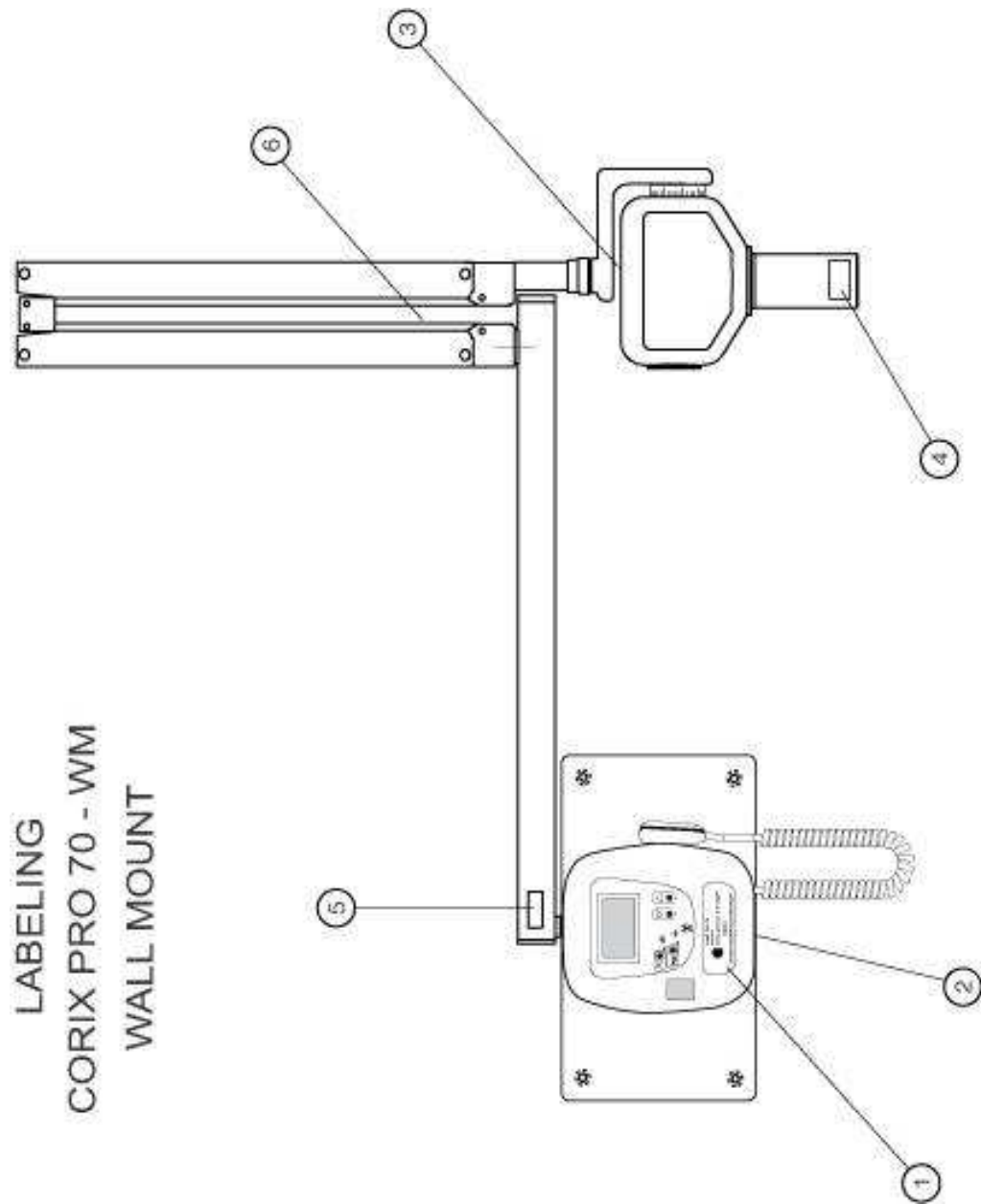

LABELING  
CORIX PRO 70 - MM  
MOBILE STAND

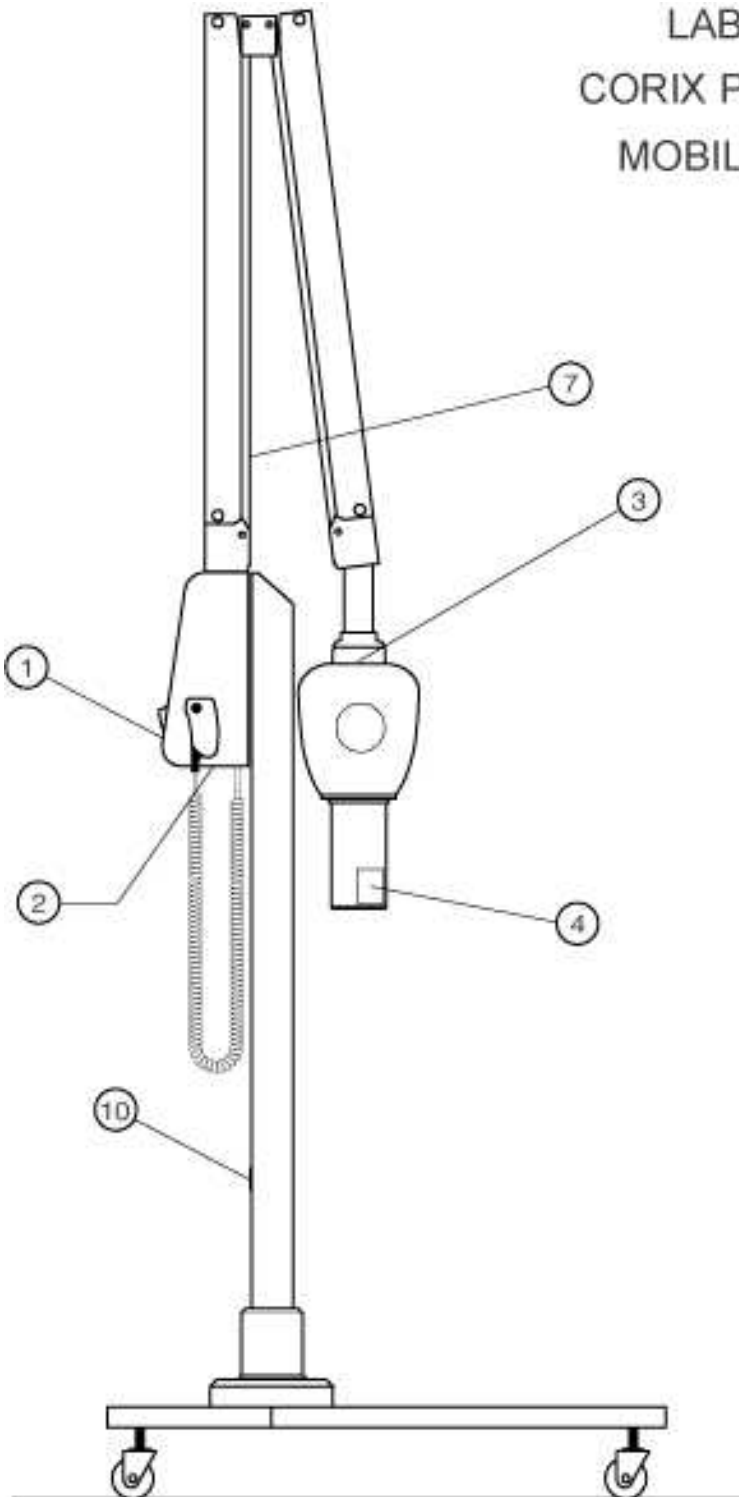

LABELING  
CORIX PRO 70 - PS  
PORTABLE STAND

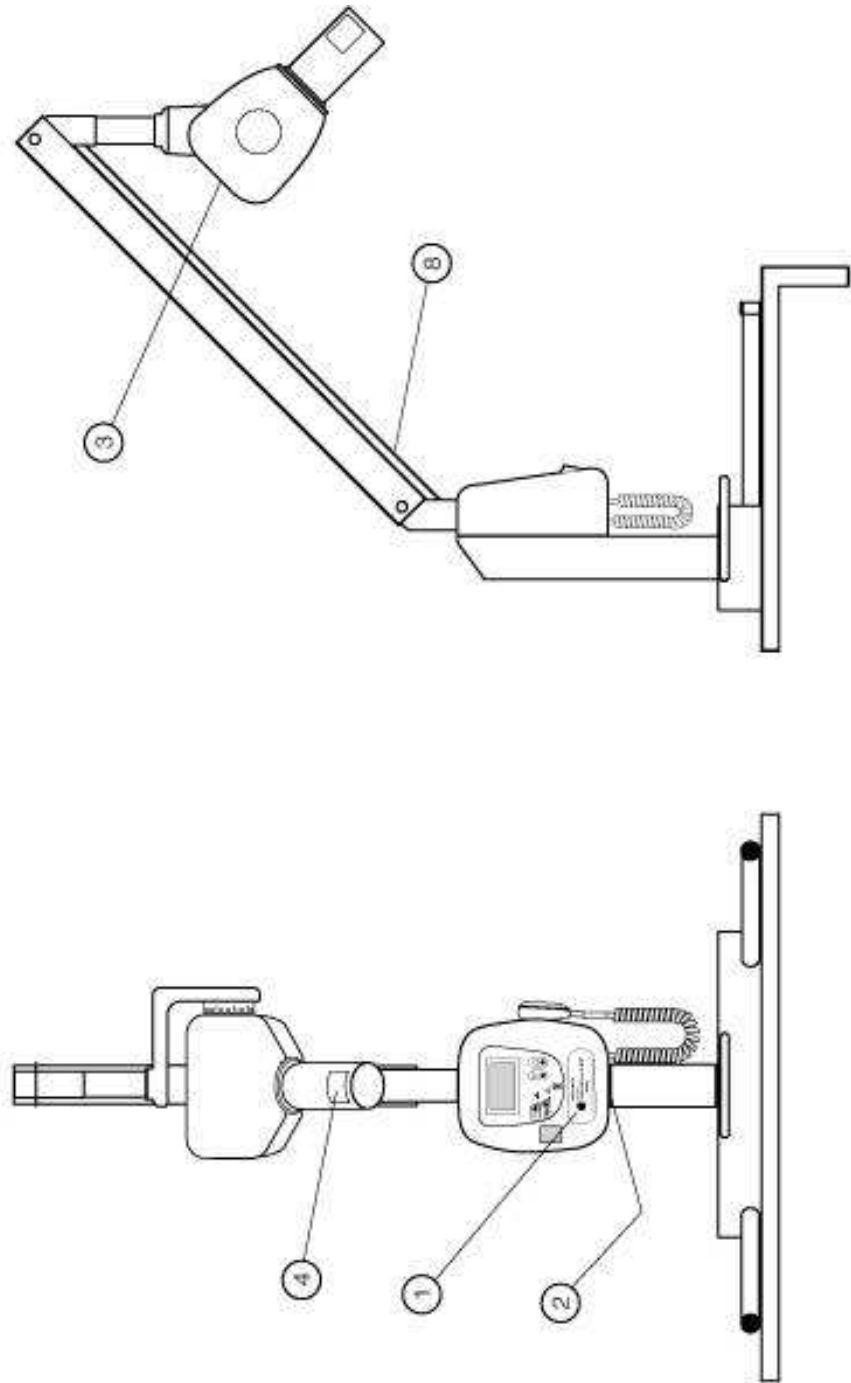

LABEL # 1

**Corix<sup>®</sup> PRO 70 70 kVp - 8mA**  
**CORIX MEDICAL SYSTEMS<sup>®</sup>**

**WARNING:**  
 THIS X-RAY UNIT MAY BE DANGEROUS TO PATIENT AND OPERATOR UNLESS SAFE EXPOSURE FACTORS AND OPERATING INSTRUCTIONS ARE OBSERVED

**ELECTRICAL SHOCK HAZARD - DO NOT REMOVE PANELS**  
 RISK OF EXPLOSION-DO NOT USE IN PRESENCE OF FLAMMABLE ANESTHETICS. FOR CONTINUED PROTECTION AGAINST RISK OF FIRE, REPLACE ONLY WITH SAME TYPE AND RATING OF FUSE.

LABEL # 2

**MANUFACTURER: CORAMEX S.A. - LAURO VILLAR No. 94-B**  
 02440 MEXICO, D.F.-MEXICO

**CONTROL PANEL P/N: R101, FOR MOD. CORIX PRO 70**

LINE VOLTAGE: 120 Vac ±10% -10 Amp 50/60 Hz

CLASS 1 TYPE B, SERIAL No.

EXPOSURE RANGE: 0.03 - 3.00 Sec.

MANUFACTURED:  MEXICO

COMPLIES WITH DHHS PERFORMANCE STANDARD 21CFR SUBCHAPTER J.  
 COMPLIES WITH UL 2606

LABEL # 4

**MANUFACTURER**  
**CORAMEX, S.A.**

LAURO VILLAR No. 94-B  
 02440 MEXICO, D.F. MEXICO

BEAM LIMITING DEVICE  
 PART -P501 USV

SOURCE TO SKIN DISTANCE (SSD): 20 cm.  
 X-RAY FIELD Ø AT MINIMUM SSD: 6 cm.

SERIAL No.

MANUFACTURED:  
  
 MEXICO

COMPLIES WITH DHHS PERFORMANCE STANDARD 21 CFR SUBCHAPTER J

LABEL # 3

**MANUFACTURER: CORAMEX S.A.**  
 LAURO VILLAR No. 94-B  
 02440 MEXICO, D.F.-MEXICO

**MOD: X-RAY TUBE HOUSING ASSEMBLY: P500 USV**  
**120 V. a.c.**

RATED PEAK TUBE POTENTIAL: 70 kVp ± 10%  
 RATED TUBE CURRENT: 8mA ± 15%  
 TOTAL FILTRATION: 2mm Al SERIAL No.

FOCAL SPOT: 0.8mm

MANUFACTURED:  MEXICO

X-RAY TUBE C.E.I. srl ITALY MOD.: OX-70-P S/N.

COMPLIES WITH DHHS PERFORMANCE STANDARD 21CFR SUBCHAPTER J.

LABEL # 5

**MANUFACTURER: CORAMEX S.A.**  
 LAURO VILLAR No. 94-B  
 02440 MEXICO, D.F. MEXICO

EXTENSION ARM. PART: P503 USV  
 Serial:

LABEL # 6

**MANUFACTURER: CORAMEX S.A.**  
 LAURO VILLAR No. 94-B  
 02440 MEXICO, D.F. MEXICO

WM FOLDING ARM. PART: P502 USV  
 Serial:

LABEL # 7

**MANUFACTURER: CORAMEX S.A.**  
 LAURO VILLAR No. 94-B  
 02440 MEXICO, D.F. MEXICO

MM FOLDING ARM. PART: P508 USV  
 Serial:

LABEL # 8

**MANUFACTURER: CORAMEX S.A.**  
 LAURO VILLAR No. 94-B  
 02440 MEXICO, D.F. MEXICO

PS FOLDING ARM. PART: P512 USV  
 Serial:

LABEL # 9

**MANUFACTURER: CORAMEX S.A.**  
 LAURO VILLAR No. 94-B  
 02440 MEXICO, D.F. MEXICO

PORTABLE BASE. PART: P513 USV  
 Serial:

LABEL # 10

**MANUFACTURER: CORAMEX S.A.**  
 LAURO VILLAR No. 94-B  
 02440 MEXICO, D.F. MEXICO

MOBILE BASE. PART: P509 USV  
 Serial:



### 3.2 Equipment Parts

A set of different models of the complete extraoral dental X-Ray device share the certified components listed

#### Model Corix PRO 70 - WM (Wall Mount)

Common Part	X-Ray Tube Housing Assembly	Cat. P500USV
	Beam Limiting Device	Cat. P501USV
	X-Ray Button, Standard	Cat. P507USV
	Control Panel	Cat. R101
Particular Part	Extension Arm, Standard (80cm)	Cat. P503USV
	Extension Arm, Large (90cm) (optional)	Cat. P504USV
	Extension Arm, Short (35cm) (optional)	Cat. P505USV
	Remote X-Ray button Kit (optional)	Cat. P514USV
	WM Folding Arm	Cat. P502USV
	Wall Plate – Double stud	Cat. P510USV
	Wall Plate – Single stud (optional)	Cat. P511USV

#### Model Corix PRO 70 - MM (Mobile Stand)

Common Part	X-Ray Tube Housing Assembly	Cat. P500USV
	Beam Limiting Device	Cat. P501USV
	X-Ray Button, Standard	Cat. P507USV
	Control Panel	Cat. R101
Particular Part	MM Folding Arm	Cat. P508USV
	Mobile Base	Cat. P509USV

#### Model Corix PRO 70 - PS (Portable Stand)

Common Part	X-Ray Tube Housing Assembly	Cat. P500USV
	Beam Limiting Device	Cat. P501USV
	X-Ray Button, Standard	Cat. P507USV
	Control Panel	Cat. R101
Particular Part	PS Folding Arm	Cat. P512USV
	Portable Base	Cat. P513USV

### 3.3 Configurations

a) Standard Configuration  
CORIX PRO 70 - WM  
WALL MOUNT

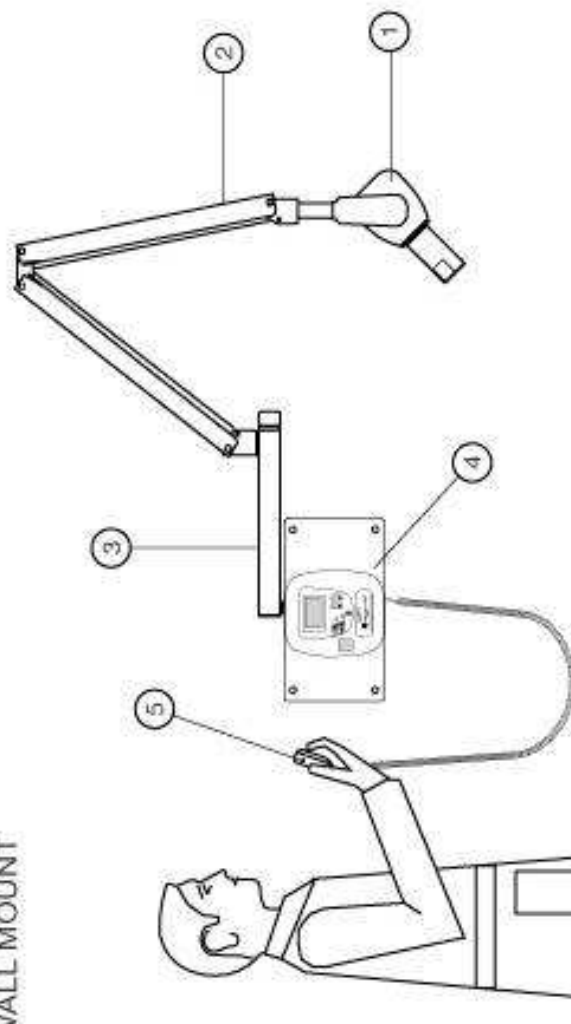

- 1 Tubehead
- 2 Folding Arm
- 3 Extension Arm
- 4 Wallplate + Control Panel
- 5 X-Ray Button

b) Remote X-Ray Button Configuration (optional)

CORIX PRO 70 - WM

WALL MOUNT

REMOTE X-Ray Button

- 1 Tubehead
- 2 Folding Arm
- 3 Extension Arm
- 4 Wallplate + Control Panel
- 5 X-Ray Button

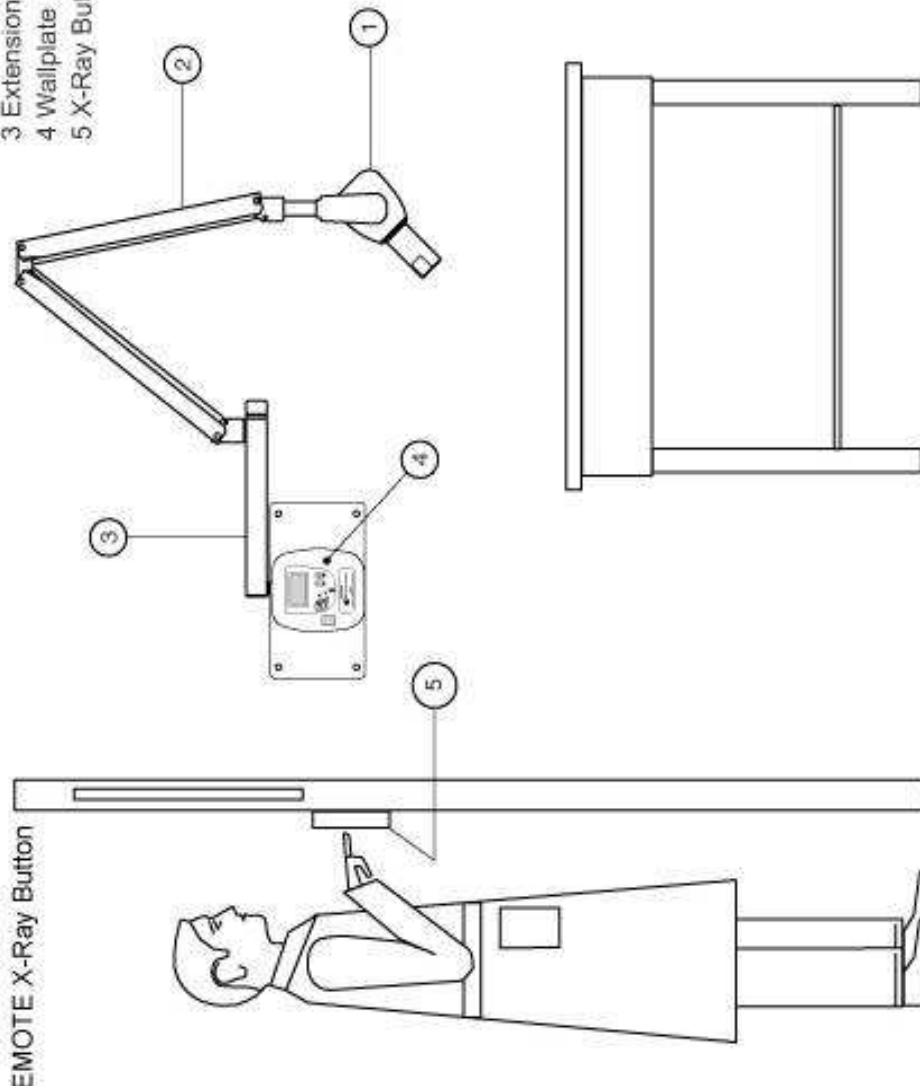

c) Mobile Stand Configuration  
CORIX PRO 70 - MM  
MOBILE STAND

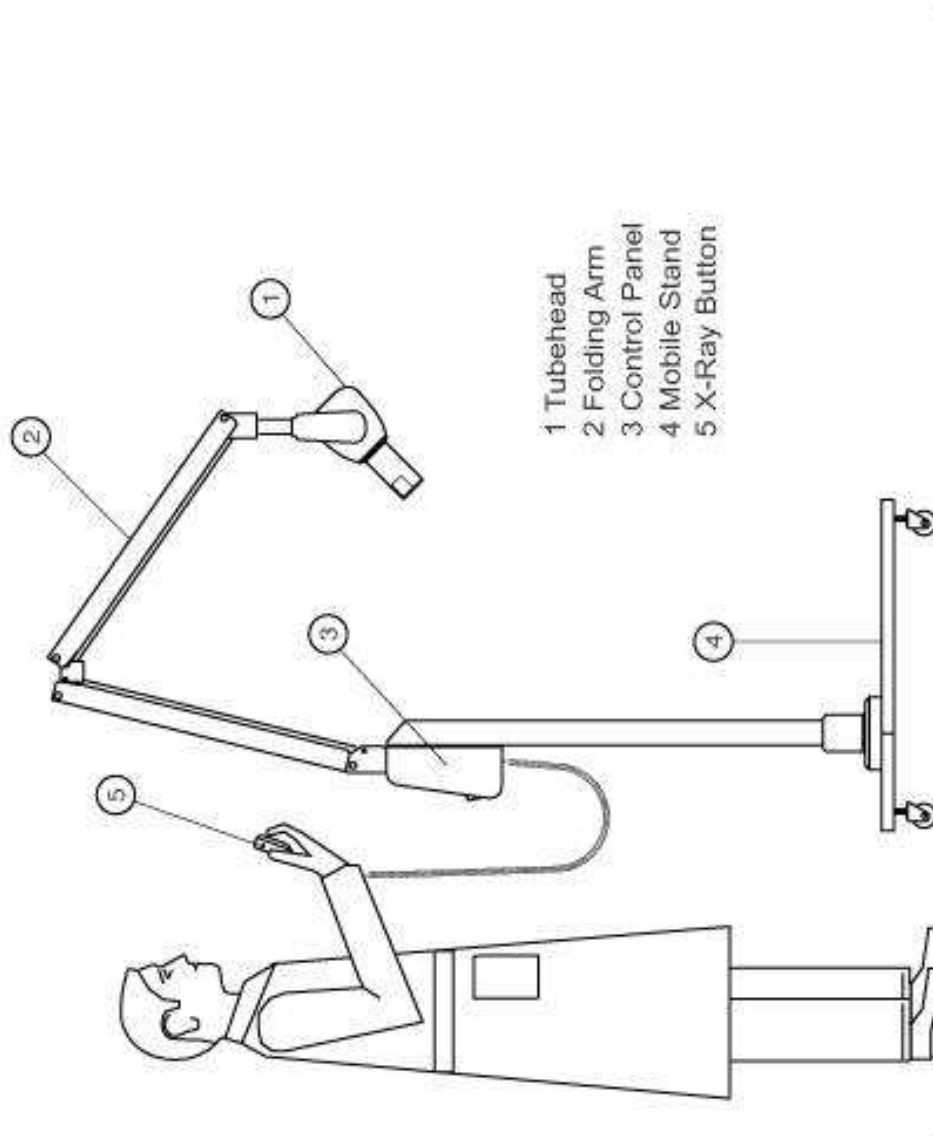

d) Portable Stand Configuration  
CORIX PRO 70 - PS  
PORTABLE STAND

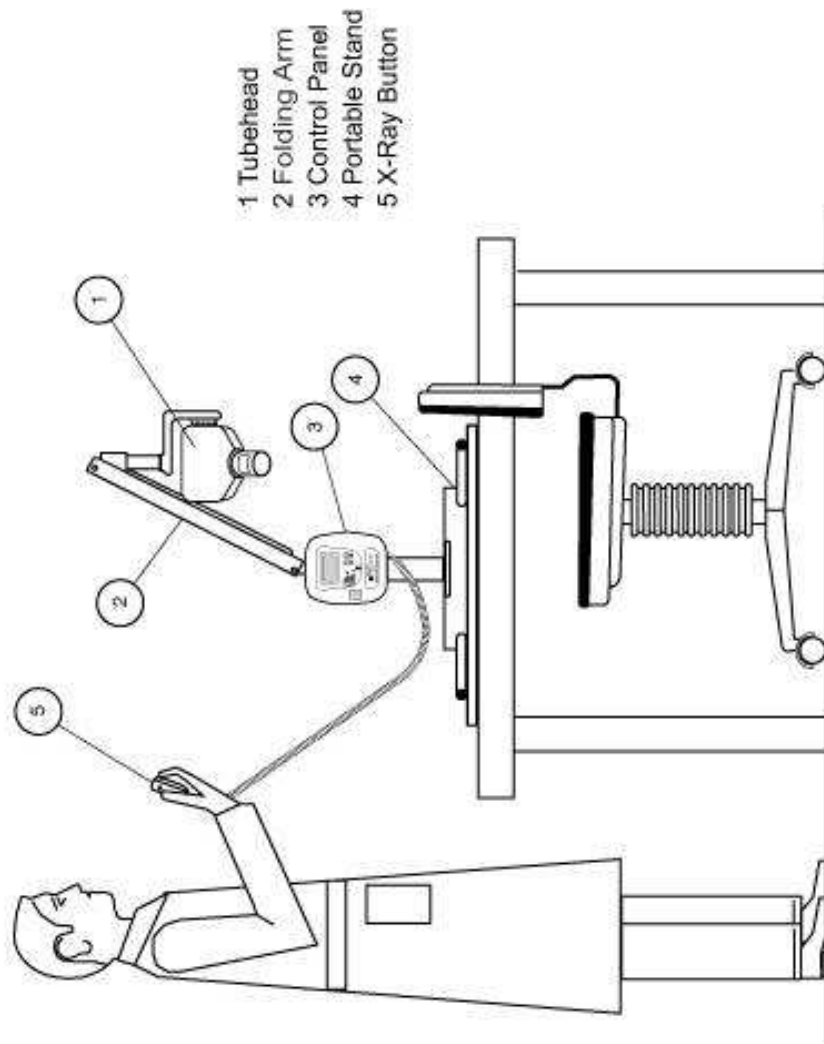

#### 4.0 TECHNICAL FEATURES

<b>Technical Features</b>	
Equipment	Extraoral Source X-Ray Imaging System (Veterinary Dental)
Manufacturer	Coramex, S.A. Lauro Villar 94-B México, D.F. 02440-México
Model Designation	Corix PRO 70
Class	I type B
Rated Line Voltage	120VAC or 230VAC $\pm$ 10%
Line Frequency	50/60Hz
Line Current	10A @ 120VAC; 6A @ 230VAC
Power Consumption	1.05 KW máx.
Apparent Line Resistance	0.2 Ohms máx. @ 120VAC
Line Voltage Regulation	$\leq$ 3%
Main Fuse	10 AF @ 120VAC; 6 AF @ 230VAC
X-Ray Control	Control Panel with Microprocessor controlled Digital Timer, Safety Relay and Back-Up Timer
Part Designation	R101
Exposure Times	Manual Time Selection from 0.03 s. to 3.00 s., in steps of 0.01s., plus 27 preset exposure times with automatic line voltage compensation (optional). Pre-heating time with 4 pre-selected values (*)
Timer Accuracy	10% or $\pm$ 32 ms (whichever is greater)

(\*) Note: "Pre-heating time" is the time required by the tube to enable the correct radiation output. When selecting an exposure time, the display reads only the exposure time, but for timing testing purposes, the actual time is the "Exposure Time" plus the "Pre-heating Time" previously selected.

Tube Housing Assembly	Extra-oral Diagnostic X-Ray generator and Beam Limiting Device
Manufacturer	Coramex S.A.
Part Designation	P500 USV
Rated Output Voltage	70 KVp $\pm$ 10% (Single phase, self rectifying)
Rated Output Current	8 mA $\pm$ 15% @ rated line voltage
Maximum Deviation of Output Current	4.5mA (over the line voltage range)
Total Filtration	2mm Al eq.
Transformer Insulation	Oil Bath
Cooling	Thermal Convection Cooling
Radiation Leakage at 1 m.	< 50 mR/h (Technical Factors 70KVp, 8mA, 1s.)
Exposure Interval (Duty Cycle)	01:30 The minimum Exposure Interval between exposures (30 time units of cooling time for every time unit of exposure) is a Preset value in the Control Panel Unit
X-Ray Tube	(Part of the Tube Housing Assembly)
Manufacturer	C.E.I., s.r.l.
Model Designation	OX/70-P, or: OCX/70-G
Focal Spot	0.8mm (IEC 336)
Inherent Filtration	0.5mm Al eq.

Beam Limiting Device	
Manufacturer	Coramex, S.A.
Part Designation	P501 USV
Minimum Focal Spot to Skin Distance (SSD)	200mm
X-Ray Field $\Phi$ at Minimum SSD	60mm

# X-RAY TUBEHEAD CURVES

## OX/70-P TUBE

**THERMAL CURVES**

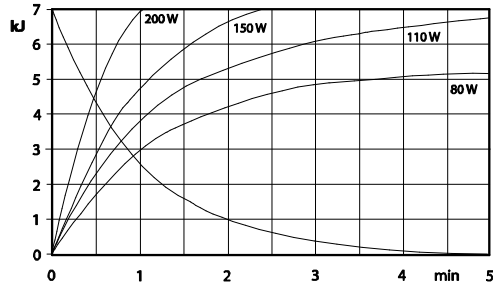

**COOLING CURVES OF TUBEHEAD**

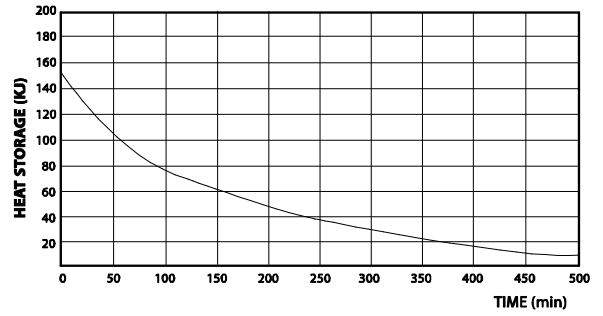

**EMISSION CHARACTERISTICS**

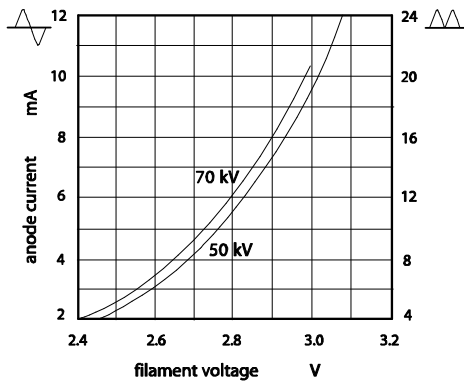

**FILAMENT CHARACTERISTICS**

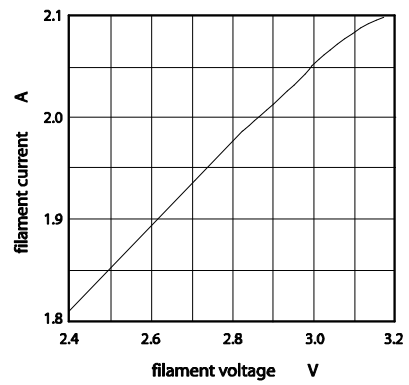

**RATING CHARTS**

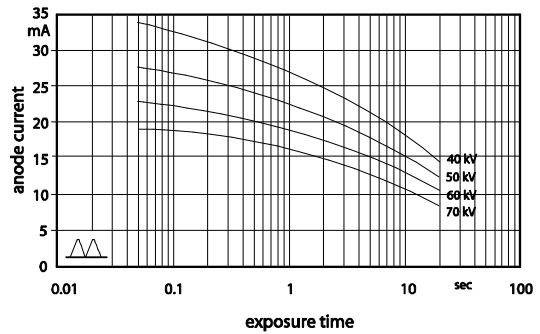
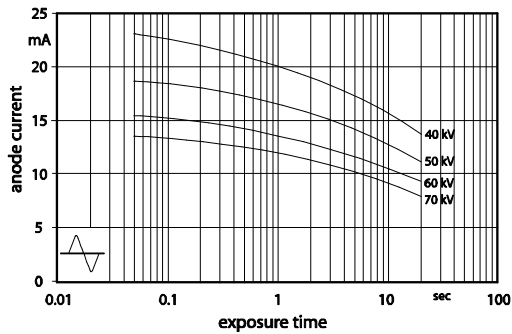



# OCX/70-G TUBE

## THERMAL CURVES

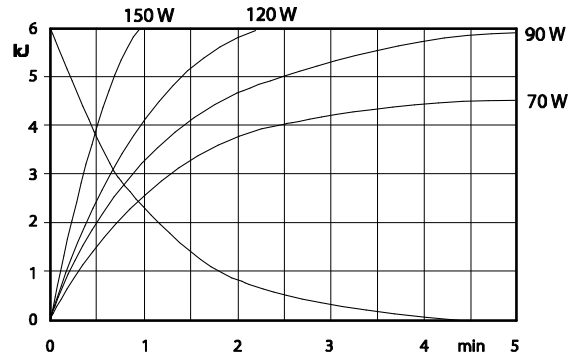

## FILAMENT AND EMISSION CHARACTERISTICS

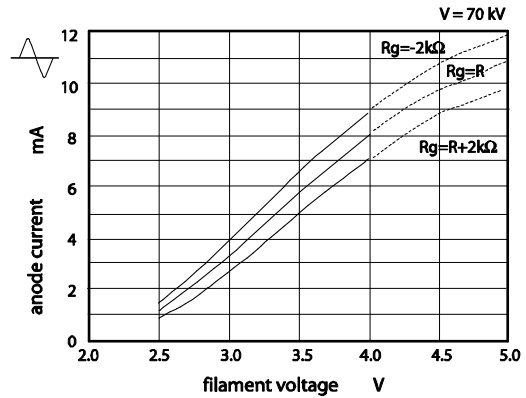
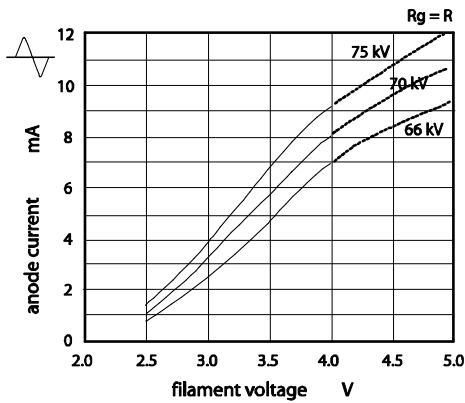
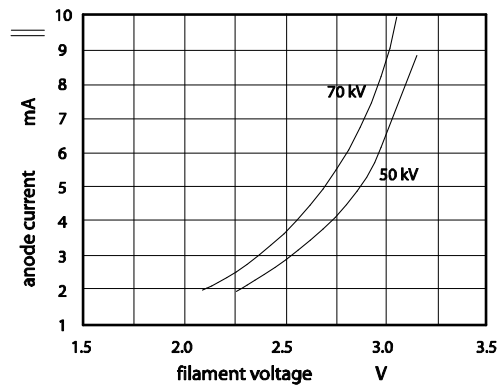
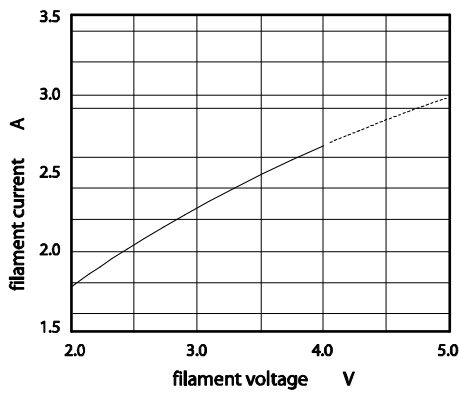

## RATING CHARTS

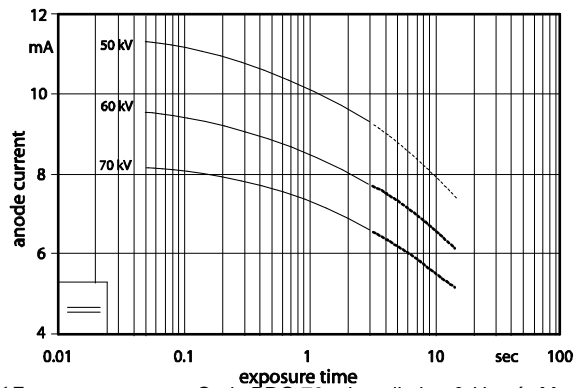
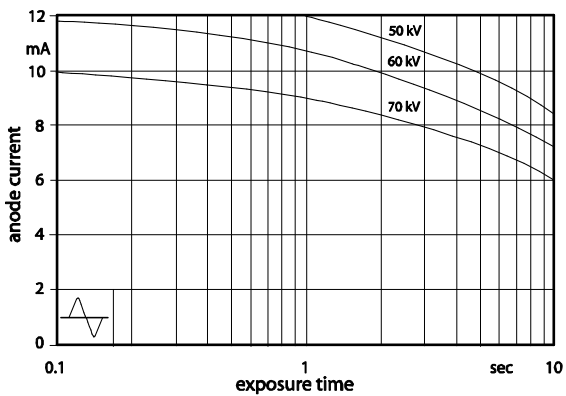

## 4.1 AUTOMATIC EXPOSURE TIME COMPENSATION

The X-Ray equipment includes a special characteristic which automatically compensates the exposure time when the line voltage is different from its nominal value. Line voltage variation affects the peak voltage applied to the Tubehead and this, in turn, affects the optimal density and contrast (visual characteristics) of the film or digital systems. With the automatic correction, it is possible to achieve the same optical quality of the image even with variations in line voltage. This automatic correction covers the range of  $\pm 10\%$  of the nominal line voltage.

To perform the time compensation, the Control Panel constantly takes samples of the line voltage. When the user chooses a pre-programmed selection, the exposure time corresponding to that selection is shown on the display. If there is a variation of the line voltage before the exposure had been taken, the Control Panel automatically calculates the corrected exposure time and shows it on the display.

The value of the correction factor has been determined empirically by measuring the radiation dose against the line voltage, keeping the exposure time constant, and then determining the correction factor in the exposure time required to keep the radiation dose constant against the line voltage.

The following graphic shows the relationship between the correction factor and the line voltage:

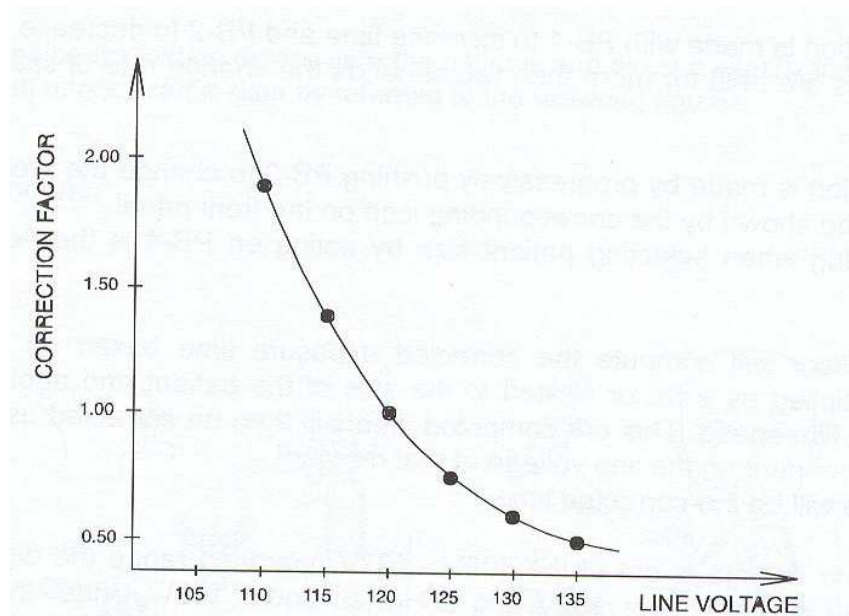

It is possible to enable or disable the automatic line voltage compensation when taking pre-programmed selections. For manual exposure times, the line voltage compensation is always disabled.

#### 4.2 PRE-SET EXPOSURE TIMES

The following tables of pre-set exposure times in seconds show the rated exposure time for a nominal line voltage of 120Vac (230Vac) and the final corrected exposure time, as a function of the line voltage correction factor, patient size and type of Film (D, F or Digital Sensor) for the minimum 108Vac (207Vac) and maximum 132Vac (253Vac) line voltage operating range.

For Film “D”:

FILM D	< 10 POUNDS			10-20 POUNDS			20-40 POUNDS			40-80 POUNDS			> 80 POUNDS		
	LINE VOLTAGE			LINE VOLTAGE			LINE VOLTAGE			LINE VOLTAGE			LINE VOLTAGE		
	108	120	132	108	120	132	108	120	132	108	120	132	108	120	132
TOOTH	207	230	253	207	230	253	207	230	253	207	230	253	207	230	253
Max I	0.30	0.16	0.09	0.46	0.24	0.13	0.49	0.26	0.14	0.72	0.38	0.21	0.72	0.38	0.21
Max C	0.42	0.22	0.12	0.53	0.28	0.15	0.57	0.30	0.16	0.76	0.40	0.22	0.76	0.40	0.22
Max PM	0.42	0.22	0.12	0.53	0.28	0.15	0.57	0.30	0.16	0.76	0.40	0.22	0.76	0.40	0.22
Max M	0.42	0.22	0.12	0.53	0.28	0.15	0.57	0.30	0.16	0.76	0.40	0.22	0.83	0.44	0.24
Mand I	0.30	0.16	0.09	0.42	0.22	0.12	0.46	0.24	0.13	0.64	0.34	0.19	0.68	0.36	0.20
Mand C	0.38	0.20	0.11	0.49	0.26	0.14	0.53	0.28	0.15	0.72	0.38	0.21	0.72	0.38	0.21
Mand PM	0.34	0.18	0.10	0.49	0.26	0.14	0.53	0.28	0.15	0.68	0.36	0.20	0.68	0.36	0.20
Mand M	0.34	0.18	0.10	0.49	0.26	0.14	0.53	0.28	0.15	0.72	0.38	0.21	0.72	0.38	0.21

For Film “F”:

FILM F	< 10 POUNDS			10-20 POUNDS			20-40 POUNDS			40-80 POUNDS			> 80 POUNDS		
	LINE VOLTAGE			LINE VOLTAGE			LINE VOLTAGE			LINE VOLTAGE			LINE VOLTAGE		
	108	120	132	108	120	132	108	120	132	108	120	132	108	120	132
TOOTH	207	230	253	207	230	253	207	230	253	207	230	253	207	230	253
Max I	0.15	0.08	0.04	0.23	0.12	0.07	0.25	0.13	0.07	0.42	0.22	0.12	0.49	0.26	0.14
Max C	0.23	0.12	0.07	0.27	0.14	0.08	0.30	0.16	0.09	0.42	0.22	0.12	0.49	0.26	0.14
Max PM	0.21	0.11	0.06	0.23	0.12	0.07	0.30	0.16	0.09	0.38	0.20	0.11	0.46	0.24	0.13
Max M	0.23	0.12	0.07	0.27	0.14	0.08	0.28	0.15	0.08	0.53	0.28	0.15	0.53	0.28	0.15
Mand I	0.15	0.08	0.04	0.21	0.11	0.06	0.27	0.14	0.08	0.40	0.21	0.12	0.38	0.20	0.11
Mand C	0.19	0.10	0.05	0.25	0.13	0.07	0.30	0.16	0.09	0.42	0.22	0.12	0.49	0.26	0.14
Mand PM	0.17	0.09	0.05	0.23	0.12	0.07	0.27	0.14	0.08	0.38	0.20	0.11	0.38	0.20	0.11
Mand M	0.19	0.10	0.05	0.25	0.13	0.07	0.30	0.16	0.09	0.42	0.22	0.15	0.38	0.20	0.11

For “Digital Sensor”:

	< 10 POUNDS			10-20 POUNDS			20-40 POUNDS			40-80 POUNDS			> 80 POUNDS		
D. SENSOR	LINE VOLTAGE			LINE VOLTAGE			LINE VOLTAGE			LINE VOLTAGE			LINE VOLTAGE		
	108	120	132	108	120	132	108	120	132	108	120	132	108	120	132
TOOTH	207	230	253	207	230	253	207	230	253	207	230	253	207	230	253
Max I	0.13	0.07	0.04	0.19	0.10	0.05	0.23	0.12	0.07	0.34	0.18	0.10	0.38	0.20	0.11
Max C	0.19	0.10	0.05	0.23	0.12	0.07	0.30	0.16	0.09	0.38	0.20	0.11	0.42	0.22	0.12
Max PM	0.15	0.08	0.04	0.23	0.12	0.07	0.27	0.14	0.08	0.30	0.16	0.09	0.34	0.18	0.10
Max M	0.19	0.10	0.05	0.23	0.12	0.07	0.27	0.14	0.08	0.38	0.20	0.11	0.49	0.26	0.14
Mand I	0.13	0.07	0.04	0.19	0.10	0.05	0.23	0.12	0.07	0.32	0.17	0.09	0.27	0.14	0.08
Mand C	0.19	0.10	0.05	0.21	0.11	0.06	0.27	0.14	0.08	0.34	0.18	0.10	0.34	0.18	0.10
Mand PM	0.19	0.10	0.05	0.19	0.10	0.05	0.23	0.12	0.07	0.30	0.16	0.09	0.30	0.16	0.09
Mand M	0.19	0.10	0.05	0.21	0.11	0.06	0.25	0.13	0.07	0.34	0.18	0.10	0.30	0.16	0.09

Notes:

- Corrected exposure times rounded to the nearest 1/100 of second.
- These tables do not show the added “Pre-heating time” selected for the x-ray tube.

### 4.3 PRACTICAL PROCEDURES FOR MEASURING TECHNICAL FACTORS

**KVp** is defined as the high voltage value applied to the X-Ray tube after pre-heating time. KVp value should be measured by a non invasive instrument with an accuracy of over 2% to the nominal value.

The anodic current value (**mA**) is defined as the average value of a steady state current through the X-Ray tube after pre-heating time.

The anodic current value should be measured using a digital voltmeter. To do this, it is necessary to remove the Tubehead plastic covers. This operation must be performed only by a qualified technician. To take this measurement, the digital voltmeter should be selected on DC and read the voltage drop at the ends of a 1K $\Omega$ , 1%, assembled on the Tubehead. The relation of transformation is given by 1mA = 1V. Execute an exposure of at least 1s.

The time interval measured from the moment where the anodic peak current first exceeds 25% of the steady state to the moment it again reaches 25% when decreases is called the exposure time (**t**).

When taking a measurement of this time, nominal line voltage should be selected, and a digital memory oscilloscope should be used to read the voltage drop across the 1K $\Omega$  resistor.

The “pre-heating time” is the time taken for the anodic current to reach 25% of its steady state value.

#### 4.4 MEASURING EXPOSURE TIMES

The use of non-invasive equipment, when measuring functional parameters of X-Ray devices like exposure time, has led to introduce some interpretation issues. The root of these issues is due to the anodic current wave form which is represented in the next figure:

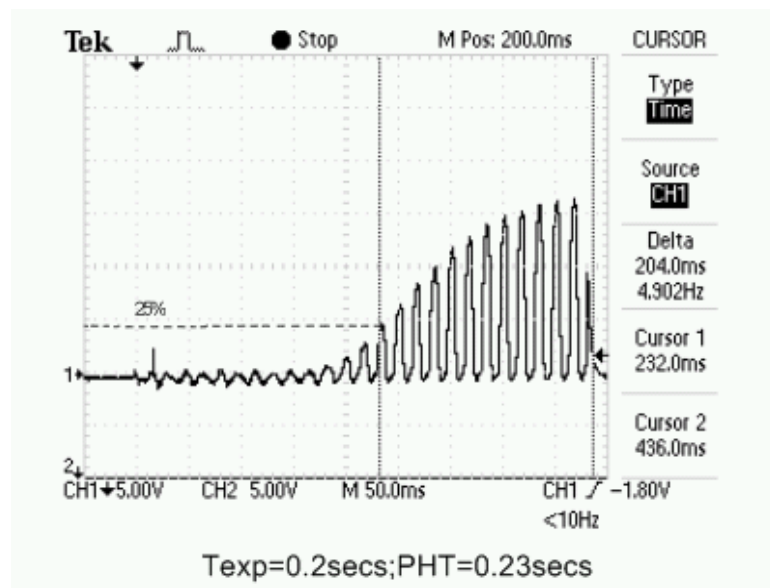

IEC 60601-2-7 (1998) regulations reads: “in equipment where the filament is switched on and high voltage is applied simultaneously, the exposure time is calculated as the interval between the instant when the anodic current exceeds 25% of the nominal value and the instant when it goes below such value”. The last figure shows the anodic current wave form for an exposure of 0.2s with a pre-heating time of 0.23s. It can be seen that the time named “Delta” measured in the interval when the anodic current exceeds 25%, represents the actual exposure time (204.0ms).

Although, non-invasive methods can be simpler to perform than the invasive methods, they may lead to errors which can be considerable when determining exposure time. Calculations of exposure time obtained by using non-invasive methods may lead to the conclusion that the unit timer is not accurate enough to meet the regulations (refer to section 4.3 Practical Procedures for Measuring Technical Factors).

## 5.0 PRE - INSTALLATION

Proper planning prior to installation is required. There are three areas of concern before installation.

- 1) Mounting structure
- 2) Reach of the tubehead
- 3) Electrical connections

⇒ **Warning**

*Precise and safe installation, of the Corix PRO 70, is the full responsibility of the installer. Inappropriate installation of the equipment may cause it to drop from its support, resulting in damage to individuals and materials near its range.*

*The manufacturer fully disclaims any responsibility expressed or implied by the actions of the installer.*

Different wall structures require different type of fasteners. It is the responsibility of the installer to use the appropriate fasteners. Always making sure that the installation is properly leveled.

*Judgment of wall sturdiness is left to the installer.*

Fixing bosses to be used for each type of wall are the following:

- ⇒ Concrete walls: expansion steel anchors
- ⇒ Wooden studs: self-threading screws
- ⇒ Hollow bricks: chemical bosses

### 5.1 Electrical Features

The supply line must meet the requirements specified on Label # 2, located on the Control Panel:

- 120 VAC +/- 10% – 10 Amp., 50/60 Hz, single-phase mains voltage + ground,  
or:

- 230 VAC +/- 10% - 6 Amp., 50/60 Hz, single-phase mains voltage + ground.

The equipment must be wired to an electrical panel whose characteristics comply with the electrical regulations in the country where it is installed. A dedicated line protected by a 10A circuit breaker is recommended.

The general ground connection must be performed according to standards of the region. Inadequate ground connection of the equipment may represent a hazard for the operator and/or cause the electrical equipment to malfunction.

Maximum distance between electrical panel and supply terminal block varies according to the section of supply wires and is reported in following table.

120 V ac, 50 / 60 Hz			
Minimum Required Size	Wire	Wire Run Distance	
12 AWG 3.3mm <sup>2</sup>		25 Feet 7.5 Meters	50 Feet 15 Meters *****
10 AWG 5.3mm <sup>2</sup>		*****	75 Feet 22.5 Meters *****

For 230 VAC supply, use wires whose section is not less than 2.1 mm<sup>2</sup> (14 AWG)

For proper functioning, the equipment must be installed in air-conditioned environments, having the following characteristics:

Relative humidity: 50-75% (not condensing)

Temperature: 18-28C

## 6.0 INSTALLATION

### ⇒ **Warning**

Coramex, S.A. is not responsible for any damage to the equipment, the operator, or to the patient, caused by the incorrect installation and maintenance not compliant with the procedures contained in the relevant Installation & User's manuals, or by incorrect operation techniques.

## 6.1 Wall, Mobile, and Portable mounting Installation

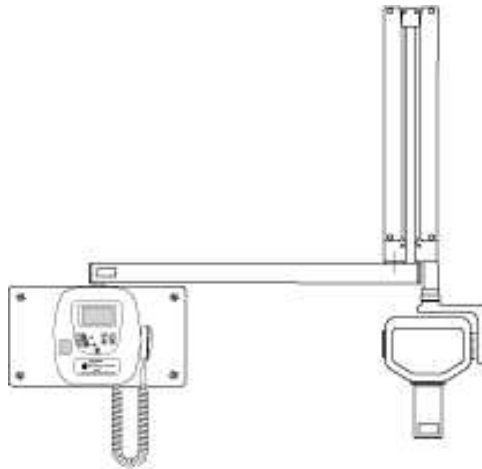

### 6.2 CORIX PRO 70 - WM (WALL MOUNT)

#### Standard Double Stud Plate

The installer must verify the consistency of the wall and must keep in mind that each set pin can carry a load of 200kg (440 pounds).

If the wall can support this weight, expansion metal steel anchors can be used.

If the fixing position has wooden studs, self-threading screws of 8 x 40 mm can be used.

If the wall is not strong enough to support the weight of the x-ray device, it will be necessary to use the optional 4 synthetic set pins, 12 mm, with bushings.

1. Check that all parts are present.
2. Check wall consistency and mark holes for Wall Plate & Control Panel mounting on wall in the selected position, at a distance of 47" (1200 mm) from floor.
3. Drill holes in wall and mount the Wall Plate. Make sure Wall Plate is leveled.
4. Make sure power wires are brought through the hole(s) located in the rear of the Wall Plate.
5. Secure Wall Plate & Control Panel to wall by using the appropriate screws.
6. Follow section 6.6 for assembling the Arm.



### **6.3 Installation of Options for mod. CORIX PRO 70 - WM (WALL MOUNT)**

⇒ **Warning**

The Manufacturer is not responsible for any damage to the equipment, the operator, or to the patient, caused by the incorrect installation and maintenance procedures as outlined in this Manual.

#### **Single Stud Plate (optional)**

This mount is available for those cases where an installation requires the use of a limited surface. The term single stud means that the stud must be at least two 2 x 4 or two 2 x 6 inch studs sandwiched together. The installer is reminded that this feature must be carefully used since the manufacturer makes no claim whatsoever as to the fitness of this installation. Most of the times this type of installation is used to mount onto a cabinet type structure or subdividing walls.

#### **Installation to brick or concrete walls**

Use steel expansion anchors to secure the Wall Plate. Follow proper shielding procedures. Always secure the Wall Plate so as to make a solid fastening. Sandy and hollow bricks may be dangerous. Consider using all thread rods or bolts to go through walls and use another external fastener or clamp to hold backing in a secure place.

#### **Remote X-Ray Button configuration (optional)**

1. For Remote X-ray Button configuration (see section 3.3,b), install the optional Remote X-ray Button outside the x-ray room and bring the extension cable to the Wall Plate. Follow section 6.2 for mounting the Wall Plate & Control Panel. Make sure that the extension cable is brought into the Control Panel through the hole(s) located in the rear of the Wall Plate.
2. Follow sections 8.1 and 8.3 for connecting the Remote X-ray Button extension cable to the relevant receptacle, located inside the Control Panel.

#### 6.4 CORIX PRO 70 - MM (MOBILE STAND)

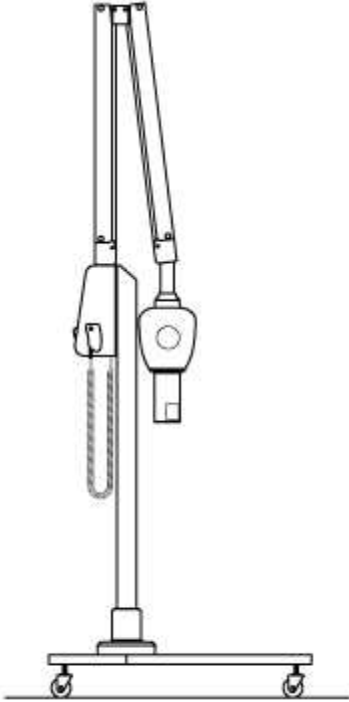

1. Make sure all parts for mobile mounting are present.
2. Cross the two Base Legs and fix them together to the Column. Make sure that the long side of the Legs is facing the front side of the equipment.
3. Follow section 6.7 for assembling the Arm.

#### 6.5 CORIX PRO 70 - PS (PORTABLE STAND)

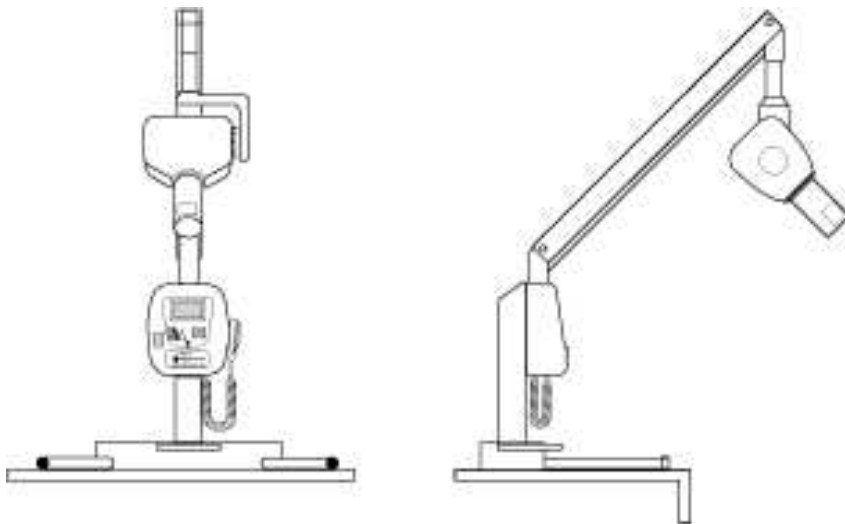

Make sure all parts for portable stand mounting are present.

1. Position Base on table to be used.
2. Fix the removable Legs into the Base.
3. Follow section 6.8 for assembling the Arm.

## 6.6 Folding and Extension Arm assembly (Wall Mount)

⇒ **Warning**

**Do not remove safety belt from scissors arm. The Scissors Arm is spring loaded and its release may be dangerous to the installer. Only, qualified technicians should attempt installation of this type of equipment.**

By means of tape, put the Folding Arm cable and Extension Arm traction wire together. Pull wire until cable appears, then separate cable from traction wire, and introduce Folding Arm pivot into Extension Arm.

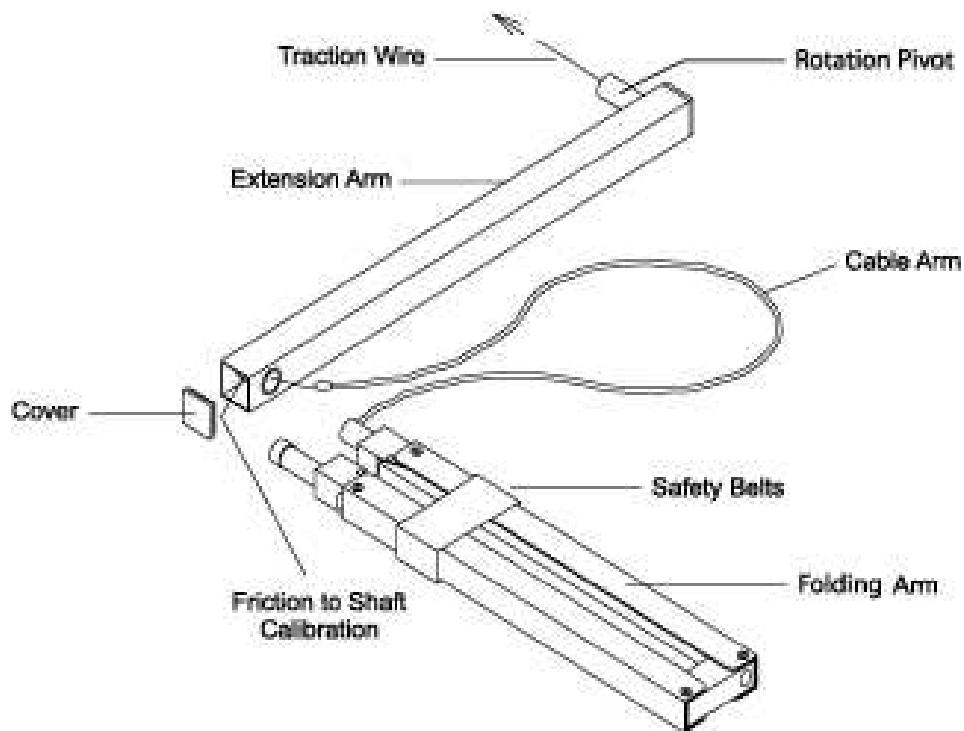

### NOTE

*Do not free Folding Arm from safety belt.*

1. By means of 3/16" hexagonal wrench remove the 1/4" Rotation Stop screw located on the rotation pivot of the Extension Arm and save it.
2. Mount complete Arm on Control Panel, by inserting rotation pivot into the relevant thimble. Keep Arm in orthogonal position with respect to Wall Plate.
3. Check that the Extension Arm this leveled through a level; the Wall Plate should be leveled horizontal and vertical, if is necessary can wear the plate against the wall to obtain the level desired.

## NOTE

*In this phase, since the Arm assembly is not supporting the Tubehead weight; it is recommended to keep the Extension Arm tilted up by about 4 mm. at its end , this allowing a leveled Extension Arm after the Tubehead assembly.*

4. Follow section 7.0 for assembling the Tubehead.

## 6.7 Folding Arm assembly (Mobile Stand)

### NOTE

*Do not free Folding Arm from safety belt.*

1. Mount Folding Arm on Control Panel, by inserting rotation pivot in the relevant thimble. Keep Arm in orthogonal position with respect to Stand.
2. Check that Folding Arm is leveled.
3. Follow section 7.0 for assembling the Tubehead.

## 6.8 Folding Arm assembly (Portable Stand)

1. Mount Folding Arm on Control Panel, by inserting rotation pivot in the relevant thimble. Keep Arm in orthogonal position with respect to Stand.

## 7.0. TUBEHEAD ASSEMBLY

For installation of Tubehead assembly, please follow the steps listed below:

⇒ **Warning**

**Folding Arm has powerful loaded spring inside. Severe damage or injury may be caused by removing the Safety Strap and free releasing it. Instead, hold the Arm firmly together and then, after removing the Safety Strap, do release the Arm tension SLOWLY by holding it all the time at its end, until it is fully opened at 90 deg.**

1. Release the Safety Strap and open the Folding Arm, as indicated.
2. By means of a 3/32" hexagonal wrench (1), remove the 8-32 Safety Screw and take away the Plastic Cover (2) from the Yoke of Tubehead (3). Do it as indicated on Fig. 1.

*Note: Retaining wedge is located under the cover.*

3. Keep Folding Arm articulation at maximum height and slide the Plastic Cover over the Connection Post (4), located at the end of the Folding Arm. See Fig. 2.
4. Completely insert the Tubehead male pivot-Post into the female Connection Post at the Folding Arm (5). By holding the weight of the Tubehead, fully insert the Retaining Wedge into the relevant Slot on the Connection Post of the Folding Arm. Do it as indicated on Fig. 2, and then slide down the Plastic Cover (7) over the Yoke (8). Make sure that the Retaining Wedge is fully inserted into the Slot and then press the Plastic Cover until it is again fully inserted over the Yoke. Do it as indicated on Fig. 3. At this point, verify that the Tubehead is fully supported by its own weight and the Arm's spring tension.
5. Insert the 8-32 Safety Screw over the Plastic Cover of the Yoke and screw it back. Do it as indicated on Fig. 3.

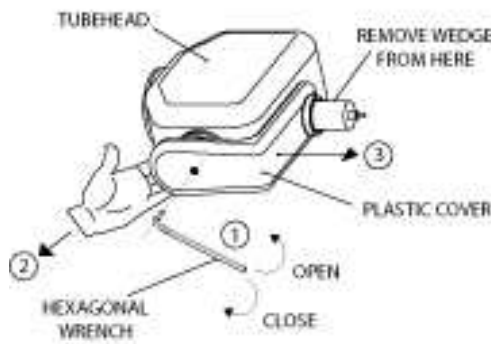

FIG. 1

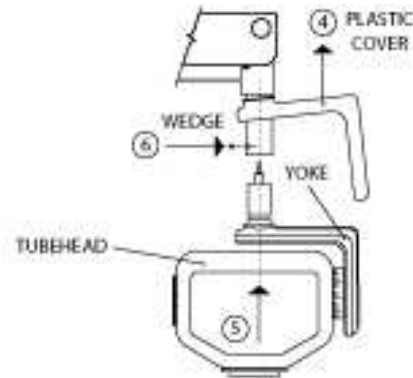

FIG. 2

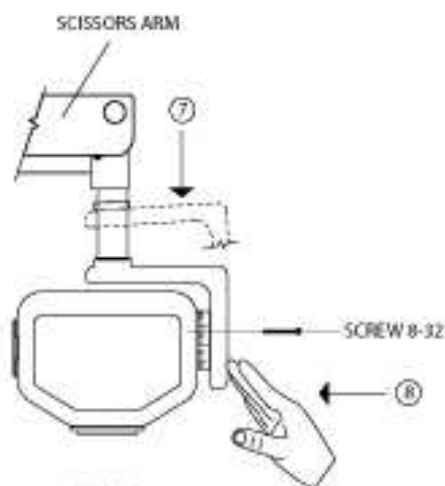

FIG. 3

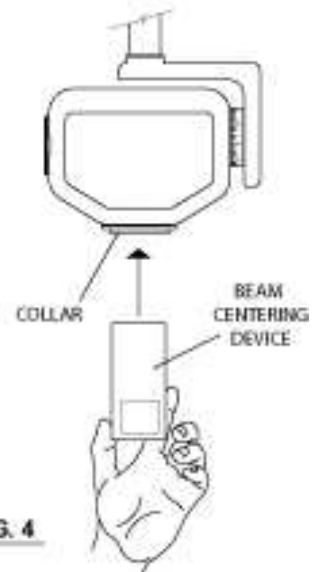

FIG. 4

## 7.1 BEAM CENTERING DEVICE ASSEMBLY

1. Align the Beam Centering Device perpendicular to the Collar on the Tubehead, around the x-ray's exit window. See Fig.4. Gently, fully screw it in, avoiding any damage to the threads.

After assembling the Tubehead, all the operation specified on section 9.2: Arm Regulation must be performed.

Coramex, S.A. is not responsible for any damage to the equipment, the operator, or to the patient, caused by the incorrect installation and maintenance procedures as outlined in this Manual.

## 8.0 ELECTRICAL CONNECTIONS TO THE CONTROL PANEL

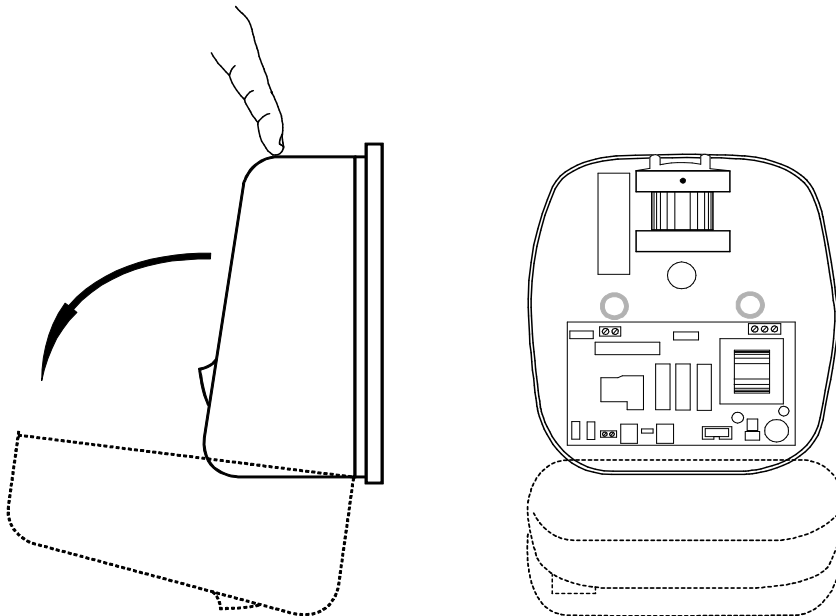

**Fig. 5**

### 8.1 Opening the Control Panel

1. Remove the Front Cover of the Control Panel from the back Plate. Unlock it by pressing the plastic button located on its upper side. See Fig. 5.
2. Let the Front Cover hang upside down, without straining the cables interconnecting the printed circuit boards.
3. Make sure power wires are brought into the Control Panel through the hole(s) in the back Plate and prepare for electrical installation.

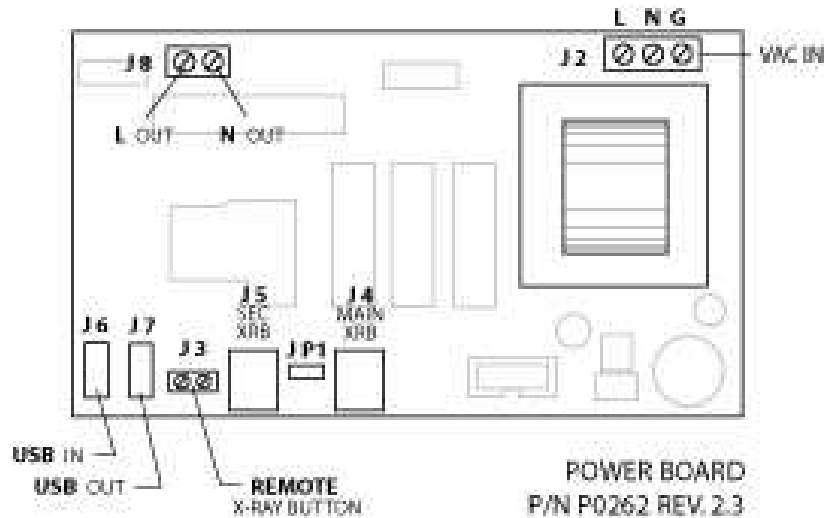

Fig. 6

## 8.2 Control Panel Assembly

(See Fig. 6)

The device must be connected to a properly grounded power source. Follow all applicable electrical regulations. Use dedicated lines with the correct gauge and circuit breakers. Refer to section 5.1 for appropriate wire size.

1. Insert power cables from the wall source into the Terminal Block: J2, VAC IN, of the Power Board, by means of a bipolar cable + ground, whose minimum gauge is specified at section 5.1. With a screwdriver, tight them into the appropriate terminal on the Terminal Block. Labels indicate the following: L = Line (black wire), N = Neutral (white wire), G = Ground wire (green cable). **Note: Mod. Corix PRO 70 - MM (Mobile Mount) has the power cable already connected by the Manufacturer to the Power Board.**
2. Make sure Tubehead cables are brought, through the Arm, into the Control Panel. Insert them into the Terminal Block J8, L OUT / N OUT, of the Power Board. Labels indicate the following: L = Line (black wire), N = Neutral (white wire). With a screwdriver, tighten them into the appropriate terminal on the Terminal Block.
3. Insert again on the rotation pivot of the Extension Arm 1/4" Rotation Stop screw.

### **8.3 Optional Wiring to the Control Panel**

#### **Remote X-Ray Button Configuration:**

If the installation is wired to enable a Remote X-Ray Button configuration, make sure that the remote X-Ray Button's extension cable has been brought through the hole(s) in the back Plate. Then remove from Receptacle: J4, MAIN XRB, on the Power Board, the coiled cable connected to the standard X-Ray Button provided with this unit, take it apart and plug-in the extension cable for the Remote X-Ray Button, or connect it to the Terminal Block: J3.

#### **2 Interlocked X-Ray Button Configuration:**

To make the equipment compliant with the regulations in some countries where two separate and interlocked x-ray buttons must be activated to allow the emission of x-ray radiation, the Control Panel is already wired to offer this option:

1. Insert the cable coming from the 2<sup>nd</sup> interlocked X-Ray Button (optional) into Receptacle: J5, SEC XRB, on the Power Board. Pass the cable through the spare strain relief Grommet, located on the bottom side of the Front Cover. Then remove Jumper: JP1 from the Power Board. By now, only when both X-Ray Buttons are pressed at the same time, the x-ray emission is enabled.

#### **Installing the Corix Digital Sensor (optional):**

The Corix Digital Sensor has been designed to be fully compatible with this x-ray equipment, by providing a docking station for it in the Control Panel. Follow the Corix Sensor Instruction Manual for installing the Sensor on the Tubehead. Insert the USB cable coming from the Sensor into Receptacle: USB IN, on the Power Board. Then connect an USB extension cable between the computer and the Control Panel, by inserting it into Receptacle: USB OUT, on the Power Board. Pass the cables through the spare strain relief Grommets, located on the bottom side of the Front Cover.

When the electrical connections to the Control Panel are done, check that all wires are properly connected, and then close again the Front Cover. Be careful to position first the bottom side of the Front Cover into the bottom side of the Back Plate, push the upper side of the Front Cover against the upper side of the Back Plate until it is firmly set.



## 8.4 Final Functioning Tests

1. Make sure that the supply line meets the requirements specified on Label # 2, located on the Control Panel, and that the equipment is properly grounded. Inadequate ground connection may represent a hazard to the operator or patient, or cause a malfunction.
2. Set circuit breaker line switch to the ON position, and then set the Power Switch located on the Control Panel in the ON position. Verify that the Power Switch is now illuminated.
3. Follow section 9.0: CONTROL PANEL OPERATING INSTRUCTIONS, and verify, step by step, the proper operation of the equipment. All equipment functions are set at standard values and are tested at the factory during final tests. Some of the functions may be regulated by Service engineers according to specific requirements.
4. X-Ray emission tests imply emission of radiation. Follow all applicable regulations and safety precautions. Position a fluorescent screen for radiation visualization at the distal end of the Beam Centering Device and then press the X-Ray Button. A Buzzer will sound, indicating x-ray emission, and both the "X-Ray" LED located on the Control Panel and the fluorescent screen will light up for the set exposure time.

## 9.0 CONTROL PANEL OPERATING INSTRUCTIONS

The Control Panel Unit includes the “Power Control Stage” and the “Timer Control Stage”. The purpose of the “Power Stage” is to supply the Main Voltage to the Tubehead. The “Timer Stage” controls the exposure timing. The Timer is built around a microcontroller IC which contains preset exposure times and Main Supply voltage variation algorithm compensations. By means of four keys, the user is able to select pre-programmed exposure times or manual exposure times. The Control Panel contains an LCD Graphic Display which allows the user to operate the timer.

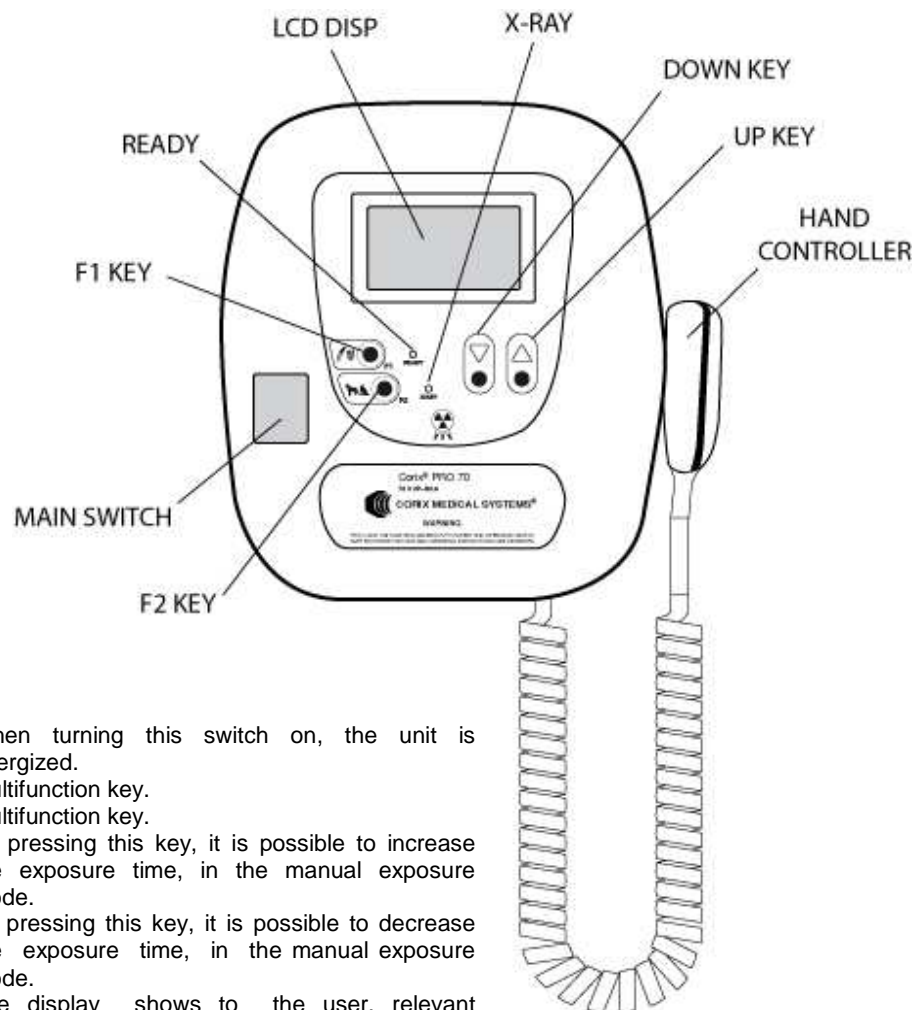

- Main Switch: When turning this switch on, the unit is energized.
- F1 Key: Multifunction key.
- F2 Key: Multifunction key.
- Up Key (▲): By pressing this key, it is possible to increase the exposure time, in the manual exposure mode.
- Down Key (▼): By pressing this key, it is possible to decrease the exposure time, in the manual exposure mode.
- LCD Display: The display shows to the user, relevant information about the Control Panel operation.
- Hand Controller: By pressing the Hand Controller button, the exposure radiation will start.

## 9.1 TURNING THE EQUIPMENT ON

When turning on the equipment, the display will show the screen presented in Fig. 1. This screen shows the Equipment Model and the software version. At this point, the equipment will execute a “self testing procedure” in order to early detect some kind of mal-functioning. This testing will take a few seconds.

Next, the display will show the screen presented in Fig. 2. At this point, if the “F1” key is depressed within 5 seconds, the “Menu” routine will be accessed. If not, the “Main” screen will be accessed.

```
CORIX PRO 70
VER 1.0

SELF TESTING
```

Fig. 1

```
CORIX PRO 70
VER 1.0

PRESS F1 FOR MENU
OR WAIT 5 SECONDS
```

Fig. 2

```
MAXILLA
0 C PM M
-----
1 C PM M
MANDIBLE

0.26 Sec
EXP-TIME

SETTINGS=
20-40 POUNDS
D-FILM
SPEED FACTOR=5

*PRESS F1=
TO SELECT TOOTH
*PRESS F2=
TO CHANGE SETTINGS
```

Fig.3

When the “Main” screen is accessed, the display will show the screen presented in Fig. 3.

Once the “Main” screen is accessed, it is possible to set pre-programmed times for automatic exposures or set the timer in manual mode. Of course, it is possible at any time to switch between automatic and manual time exposures.

## 9.2 AUTOMATIC EXPOSURE TIME SELECTION

Back to the screen presented in Fig.3, we can identify 4 different zones:

- At upper left, Maxilla and Mandible teeth are shown. In this particular screen, “Maxilla Incisive” is selected.
- At upper right, the settings selected for the current patient are shown. In this particular screen, the patient size (in pounds) selected is “20-40 Pounds”; the film selected is “D Film” and the “Speed Factor” selected is “Five”.
- At lower left, the current exposure time is shown (the exposure time value is only an example).
- At lower right, instructions to select a tooth or for changing the settings are shown.

In order to select a specific tooth, “F1” key should be pressed. When pressing “F1” successively, it is possible to select the desired tooth. By instance, from the Fig.3, if we wish to select “Mandible Canine” tooth, we should press “F1” key five times (see Fig. 4).

If we would need to change the settings according to a different patient size, type of film or speed factor, “F2” key should be pressed (see Fig. 5). By pressing “Up” or “Down” keys, we can select a different patient weight.

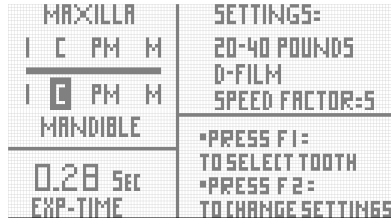

Fig. 4

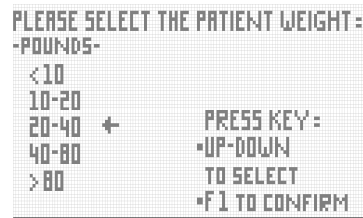

Fig. 5

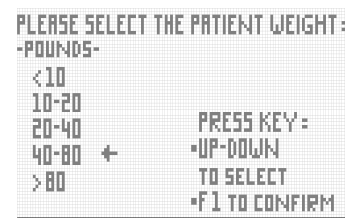

Fig. 6

In Fig. 6, we have selected “40-80” pounds. Now, to exit this screen, “F1” key should be pressed.

Now, we are able to select the “Film” type (see Fig. 7). By pressing “Up” or “Down” key we can select films “D” and “F” type, or the option for “Digital” sensor. In Fig. 8, we have selected “F-FILM”.

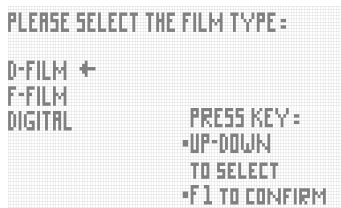

Fig. 7



Fig. 8

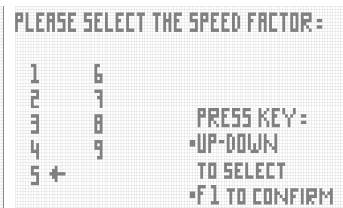

Fig. 9

By pressing “F1” key, we leave this screen. Then, in Fig. 9, we can select the “Speed Factor”. This factor increases or decreases the nominal exposure time by a 10% quantity. Number “5” is the nominal exposure time. If we select number “6”, the exposure time will be increased by a factor of 10%. Selecting “7”, the time will be increased 20%. Selecting “8”, 30% and “9”, 40%. On the contrary, if we select number “4”, the time will decrease by a factor of 10%; number “3”, time will decrease by a factor of 20%; number “2”, factor of 30%; number “1”, factor of 40%. The factor can be selected by pressing “Up” or “Down” keys. For the time being, we do not change the factor and press “F1” to abandon this screen.

In Fig.10, now we can see the “Main” screen with the current settings. At this time, an exposure can be made by pressing down the “Hand Controller” switch.

MAXILLA	SETTINGS=
I C PM M	40-80 POUNDS
I C PM M	F-FILM
MANDIBLE	SPEED FACTOR=5
0.18 Sec	*PRESS F1:
EXP-TIME	TO SELECT TOOTH
	*PRESS F2:
	TO CHANGE SETTINGS

Fig.10

MAXILLA	SETTINGS=
I C PM M	40-80 POUNDS
I C PM M	F-FILM
MANDIBLE	SPEED FACTOR=5
0.17 Sec	*PRESS F1:
EXP-TIME>MAN	TO SELECT TOOTH
	*PRESS F2:
	TO CHANGE SETTINGS

Fig.11

MAXILLA	SETTINGS=
I C PM M	40-80 POUNDS
I C PM M	F-FILM
MANDIBLE	SPEED FACTOR=5
0.20 Sec	*PRESS F1:
EXP-TIME>MAN	TO SELECT TOOTH
	*PRESS F2:
	TO CHANGE SETTINGS

Fig. 12

### 9.3 MANUAL EXPOSURE TIME SELECTION

If manual selection operation mode is preferred, you can switch to “Manual Exposure Time Mode” by pressing “Up” or “Down” keys from the automatic exposure time selection at any moment. For instance, if we press “Up” key from the screen of the Fig. 10, then we will get the screen shown on Fig. 11. At lower left, the message “EXP-TIME>MAN” indicates that the “Manual Exposure Time Mode” has been selected. From this point, the exposure time can be increased or decreased by pressing “Up” or “Down” keys. By instance, if we press three times the “Up” key, then the exposure time will be incremented to 0.20 (see Fig. 12). To return to the “Automatic Exposure Mode”, “F1” or “F2” keys should be pressed.

### 9.4 STARTING AN EXPOSURE

After having selected the exposure time, in automatic or manual mode, the system will be prepared to start an X-Ray exposure. A green LED identified as “Ready” located at the “Control Panel” (see section 9.0) will turn on indicating that an exposure can be started immediately.

To start an exposure, press down the “X-Ray” button located at the “Hand Controller” (see section 9.0). An amber LED identified as “X-ray” located at the “Control Panel” (see section 9) will turn on and an audio feedback warning sound will be emitted. The initial exposure time indicated on the LCD Display will be decremented to 0.00 sec.

**WARNING: X-Ray button must be kept depressed throughout the exposure. If the patient should move during the examination, the button must be released, thereby interrupting the emissions.**

If the X-Ray button is released before the end of the exposure time, the “Warning Message” presented in Fig. 13 will be shown on the display alerting the user that the exposure was aborted. To resume the normal operation, press any key.

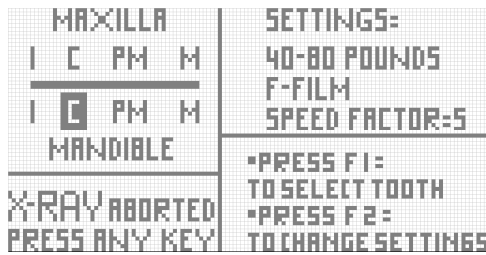

Fig. 13

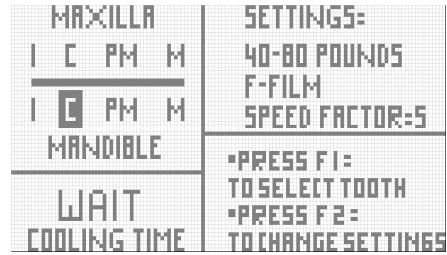

Fig. 14

### 9.5 COOLING TIME MODE

Once the exposure is finished, the system will turn to the cooling time cycle. During this period, the equipment is not enabled to take an exposure. The display will show the screen presented in Fig.14.

The message “Wait cooling time” will be flashing during the entire cooling cycle.

When the cooling cycle finishes, the system will resume its last operation mode (manual or automatic) and the display will show the last pre-selected values. At this point, the equipment is ready to take another exposure keeping the same selected values or, if the operator wishes, to change the parameters for a new exposure.

### 9.6 MENU OPERATION MODE AND PARAMETER SET-UP

Referring to the Fig2, if the “F1” key is pressed within 5 seconds, the “Menu operation mode” will be accessed and the display will show the screen presented in Fig. 15.

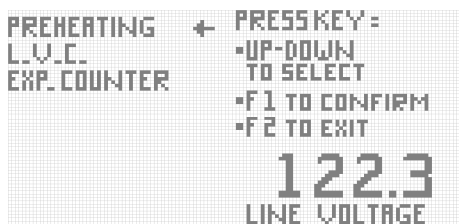

Fig.15



Fig. 16

On this screen, at lower right, a “four digit” voltmeter readout is shown. The Main AC Power Supply Voltage is constantly monitored by this voltmeter.

There are several factory pre-programmed parameters that the user may change. To navigate through this screen, four keys are used:

“Up” or “Down” keys to move among submenus.

“F1” key to access or confirm a submenu.

“F2” key to abandon submenus or the main menu.

From the screen on the Fig. 15, if “F1” key is pressed, then we access the “Preheating” submenu (see Fig 16). In this sub-menu, the “Pre-heating Time” can be modified. The factory pre-programmed pre-heating time value is 0.23s. It is strongly recommended that the user does not change this parameter unless asked by the Original Manufacturer. For changing this parameter, select it and then press “F1” key. If the value is not going to be changed, press “F2”.

Now, the display will show the screen of the Fig. 17. The Line Voltage Compensation (L.V.C.) can be disabled or enabled with this sub-menu. By pressing “F1” key, the screen presented in Fig. 18 will be shown.



Fig. 17

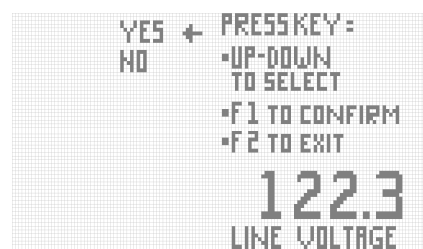

Fig. 18

The factory pre-programmed L.V.C. status is “enabled”. The arrow points to the word “YES”. To disable this function, press “Up” or “Down” key to point the word “NO”. To exit this sub-menu, and confirm the selection “F1” key should be depressed. If the “L.V.C.” status is not going to be changed, press “F2”.

Now, the display will show the screen of Fig. 19. By selecting this sub-menu pressing “F1” key, the number of exposures taken with the equipment will be shown (see Fig. 20). This screen shows the number “24” indicating that 24 exposures have been taken by the equipment. To leave this submenu, press “F2”.



Fig. 19



Fig. 20

Now, the display will show the screen presented in Fig. 15. Up to this point, if you wish to change again any parameters, follow the procedure already explained. If not, press “F2” key to exit the menu operation mode.

## 9.7 ERROR AND FUNTIONAL MESSAGES

The Control Panel is provided with a self diagnostic function which constantly monitors the system and its most important safety circuits. When a problem occurs, the system will show a message on the display to alert the user of this situation.

The next table shows a description of the error messages:

DISPLAY ERROR NUMBER	FAILURE TYPE	PROCEDURE
E00	Program memory (Flash) or data memory (Eeprom) corrupted	Turn the power system off immediately. The equipment may not operate correctly.
E01	Tubehead block may be power supplied continuously during start-up secuence	Turn the power system off immediately. Serious faililure of the power system. Safety relay and TRIACS may be short circuited
E02	Tubehead block maybe power supplied when safety relay is activated during start-up secuence	TRIACS maybe short circuited. X-Ray exposure is controlled only by the back-up timer (5 secs maximun exposure.)
E03	Tubehead block maybe power supplied when safety relay is off and triacs are activated during start-up secuence	Safety relay maybe short circuited. Safety relay driver maybe damaged
E04	"F2" button closed at start-up	Button damaged. Harness damaged
E05	"F1" button closed at start-up	Button damaged. Harness damaged
E06	"Increase" button closed at start-up	Button damaged. Harness damaged
E07	"Decrease" button closed at start-up	Button damaged. Harness damaged
E08	"X_Ray" button closed at start-up	Button damaged. Harness damaged
E09	Tubehead supplied when closing safety relay and TRIACS are OFF during X-Ray exposure secuence	TRIACS damaged Exposure will end when safety relay is off or controlled by the back-up timer (5 secs maximun exposure)
E10	Tubehead not supplied when closing safety relay and TRIACS have been activated during X-Ray exposure secuence	TRIACS and/or safety relay damaged. There is no exposure radiation
E11	Tubehead still supplied when turning the TRIACS off and safety relay is on during X-Ray exposure secuence	TRIACS damaged Exposure will end when safety relay is off or controlled by the back-up timer (5 secs maximun exposure)

The control unit is constantly monitoring the Main Line Voltage. If the line voltage is lower than 10% of the nominal line voltage, the display will show the message presented in the Fig.21. If the line voltage is higher than 10% of the nominal line voltage, the display will show the message presented in Fig. 22.



MAXILLA	SETTINGS=
I C PM M	40-80 POUNDS
I <input checked="" type="checkbox"/> PM M	F-FILM
MANDIBLE	SPEED FACTOR=5
LOW	*PRESS F1=
LINE VOLTAGE	TO SELECT TOOTH
	*PRESS F2=
	TO CHANGE SETTINGS

Fig. 21

MAXILLA	SETTINGS=
I C PM M	40-80 POUNDS
I <input checked="" type="checkbox"/> PM M	F-FILM
MANDIBLE	SPEED FACTOR=5
HIGH	*PRESS F1=
LINE VOLTAGE	TO SELECT TOOTH
	*PRESS F2=
	TO CHANGE SETTINGS

Fig. 22

Once the line voltage returns to its operating range, the control unit automatically resumes its operation and the display will show the screen presented in Fig. 15.

## 9.8 Positioning the tubehead for exposures

- Arrange the tubehead with an angle suitable for the required exposure and positioning.
- Introduce the film into the patient's mouth according to the chosen technique (bisecting or parallel).
- Move the beam limiting device near the animal and direct it exactly towards the tooth under examination by referring to Mulligan, Thomas W., Aller, Mary Suzanne, Williams, Charles A. (1998). *Extraoral Imaging Techniques*. In: Mary Suzanne Aller *Atlas of Canine & Feline Dental Radiography*. Yardley, Pennsylvania: Veterinary Learning Systems. p23-26

### Exposure techniques

Please, refer to Mulligan, Thomas W., Aller, Mary Suzanne, Williams, Charles A. (1998). *Intraoral Imaging Techniques*. In: Mary Suzanne Aller *Atlas of Canine & Feline Dental Radiography*. Yardley, Pennsylvania: Veterinary Learning Systems. p27-44

### Bisecting angle and Parallel techniques

Please, refer to Mulligan, Thomas W., Aller, Mary Suzanne, Williams, Charles A. (1998). *Projection Geometry*. In: Mary Suzanne Aller *Atlas of Canine & Feline Dental Radiography*. Yardley, Pennsylvania: Veterinary Learning Systems. p15-22

## **10.0 PROTECTION AGAINST RADIATION**

Radiation protection is generally regulated by law.

Trained personnel only are allowed operation and use of the equipment.

- The film / digital sensor must be introduced into the patient's mouth manually or by means of the relevant holders.
- During radiation exposure, the operator must not be in contact with the Tubehead or the Beam Centering Device.
- During radiation exposure, only the operator and patient must be allowed in the room.
- To reduce the unwanted effects of secondary radiation on the patient, we suggest using the relevant leaded aprons.

## 11.0 CHECKS AND CORRECTION OF POSSIBLE FAULTS IN DENTAL RADIOGRAPHS

Typical defects of intra-oral radiology	Possible causes:
Light radiographs / grainy image with the Digital Sensor	Insufficient exposure to X-ray (short time) Insufficient development time Deteriorated developer Developer temperature below recommended value Incorrect developing fluid dilution
Dark radiographs:	Excessive exposure to X-ray (long time) Excessive development time Developer temperature above recommended value Incorrect developing fluid dilution
Blurred radiographs (details not visible):	The patient moved The tubehead moved
Partially exposed radiographs:	X-ray directed off the film's mid section Low developmental fluid level, with consequent partial film development Two or more films placed against each other during development
Clouded radiographs:	Excessive film shelf life (check expiration date) Film accidentally exposed to X-ray Film accidentally exposed to other natural or artificial light sources
Radiograph showing a black line:	This line appears when the film is excessively folded
Radiographs showing signs of electrostatic charge:	When film is compressed too much and the air is dry, static electricity may be released discharging in the compensation points, which display black marks.
Film with chemical spots:	Development and fixing fluid spattered on the film before development and fixing procedures produces spot on the radiograph; such spots are: Dark, when caused by development fluid Light when caused by fixing fluid
Film with emulsion coming off:	If the film is kept in a hot water bath too long (e.g. throughout the whole night), the emulsion may become softer and partially come off the film base. After development, the film will show scratches.
Typical defects caused by incorrect positioning	
Radiographs with elongated or shortened image:	The main beam is not perpendicular to the bisecting of the angle formed by the tooth longitudinal axis and the film.
Film with stretched out tip tooth	Probably caused by excessive film folding inside patient's mouth.

## **12.0 MAINTENANCE**

### **12.1 General Features**

This equipment requires proper operation, periodic maintenance and servicing. The following precautions will ensure safe and effective functioning of the system.

Periodic maintenance consists of system checks directly performed by the operator and / or by Technical Service.

Checks directly affected by the operator/technician are:

- Check that labels are intact and properly secured
- Check that Tubehead is free from oil residues
- Check that standard, coiled cable, X-Ray Button is not broken or worn out
- Check for external damage in the Tubehead, which may prejudice protection against radiation
- Check Arm balancing
- Check centering of the X-Ray beam

Checks should be performed before any operating session. In case of irregularities, the operator shall contact Technical Service.

### **12.2 Arms Regulation (See Fig. 1 of section 12.4)**

Arms regulations do not require removal of Tubehead.

Arms regulation may be necessary in the following cases:

Folding Arm is not perfectly balanced; in this case, operate on spring regulation.

After a certain time, arms balancing springs may sag. Should this happen, tubehead will no longer be balanced in all positions and spring calibration will be required.

### **12.3 Balancing of the Folding Arm**

1. Observe Arms to determine which one requires adjustment (Anterior or Posterior).
2. Position the Folding Arm as show in (See Fig. 1 of section 12.4)
3. Locate and remove the Cover Plug of the Arm that requires adjustment.
4. Insert the hexagonal key and rotate clockwise if the Arm tends to go down, or rotate counter clockwise if the Arm tends to go up.
5. Once adjustment is finished replace Cover Plug.

## 12.4 Extension arm friction regulation (Wall Mount version)

Make sure that the Extension Arm is leveled through a level, otherwise the drift-free condition could not be achieved.

There are 2 adjustment points for the Extension Arm:

- Behind the plastic Cover, at the Folding Arm's end.
  - Inside the Control Panel, where the rotation pivot is inserted.
1. Locate and remove the plastic Cover at the end of the arm and open the Control Panel (see instruction at section 8.1).
  2. Access the friction setting screws.
  3. Regulate friction by means of a 3.2 mm. (1/8") hexagonal wrench and check arm rotation.
  4. Once friction adjustment is achieved replace Covers.

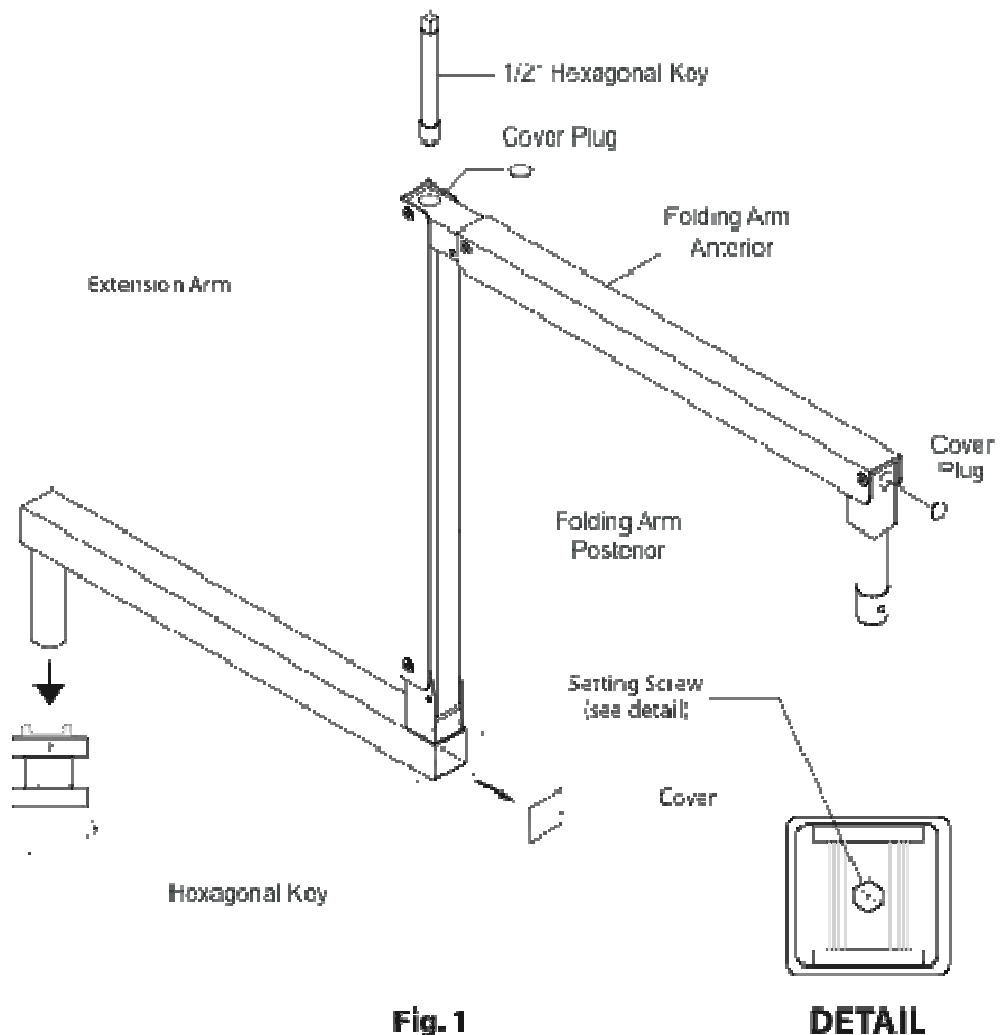

## 12.5 LOGIC BOARD ADJUSTMENTS AND SETTINGS

### a) Nominal Operating Line Voltage Setting

This setting is controlled by the Dip Switch "SW1" (see Fig. 2) according to the next table

	S1	S2
Rated line Voltage		
120VAC	OFF	OFF
127VAC	ON	OFF
230VAC	ON	ON

The Dip Switch is preset in the Factory and must never be changed by the user.

### b) Internal Voltmeter Calibration

This adjustment is controlled by the Trimmer "POT1" (see Fig. 2) It is preset in the Factory and must never be changed by the user.

### c) LCD Display Contrast Adjustment.

This adjustment is controlled by the Trimmer "POT2" (see Fig. 2) It is preset in the Factory and if necessary, it may be changed by the user.

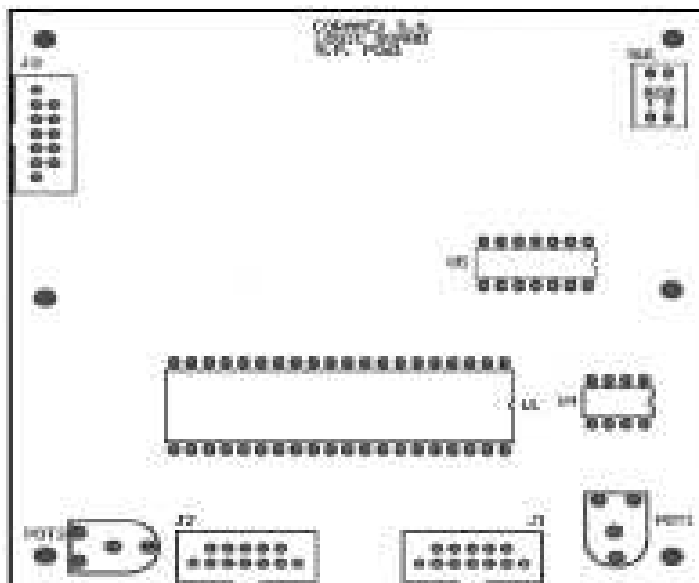

**Fig. 2**

## 12.6 FUSES

FUSE TABLE		
FUSE	120VAC	230VAC
F1	10AF 6.3 x 32	6AF 6.3 x 32
F3	10AF 6.3 x 32	6AF 6.3 x 32
F2	500mAF 6.3 x 32	500mAF 6.3 x 32

## 12.7 CLEANING AND DISINFECTING

Gently wipe metal and plastic components with damp cloth and dry. Use liquid soap. Do not drip liquids inside the enclosures.

## 13.0 ENVIRONMENTAL RISKS AND DISPOSAL

Upon completing the product's life cycle, it must be disposed according to your local laws. The equipment contains the following materials or components:

Glass, copper, iron, lead, mineral oil, rubber, semiconductors and non-biodegradable plastic materials.

The manufacturer will not be responsible for the disposal of the product.

## 14.0 DRAWINGS AND ELECTRICAL SCHEMES

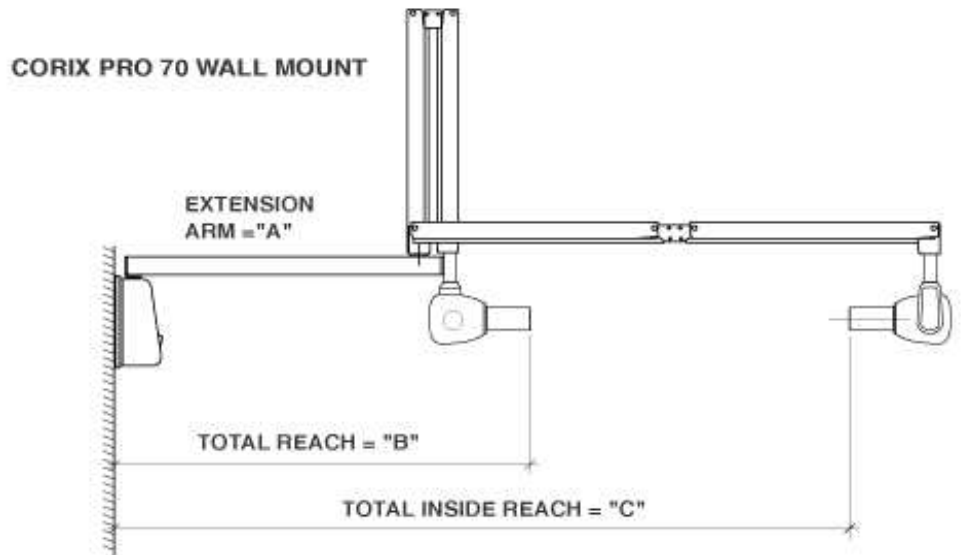

EXTENSION ARM="A"	TOTAL REACH="B"	TOTAL REACH="C"	INSIDE	DISTANCE="D"
13 3/4" (35 cm)	25 3/4" (65.4 cm)	53 3/8" (135.6 cm)		27 3/8" (69.4 cm)
ST 31 1/2" (80 cm)	43 1/2" (110.5 cm)	71 1/8" (180.6 cm)		45" (114.4 cm)
35 3/8" (90 cm)	47 1/2" (120.6 cm)	75" (190.6 cm)		49" (124.4 cm)

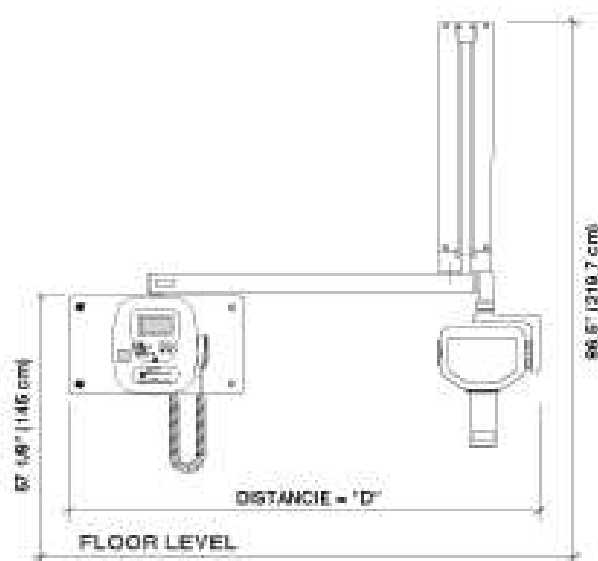



## Electrical Schemes

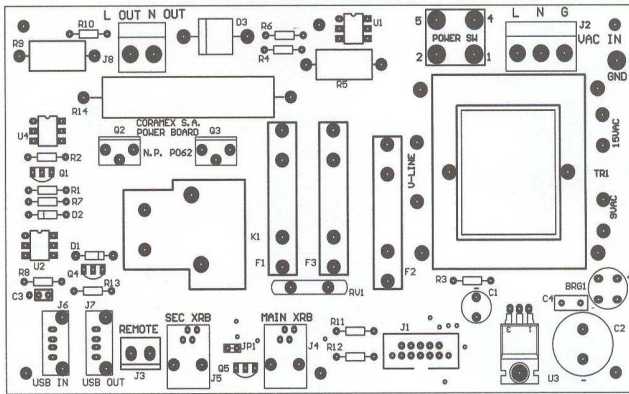

CORIX PRO 70  
POWER BOARD LAYOUT  
ASSY PN R072

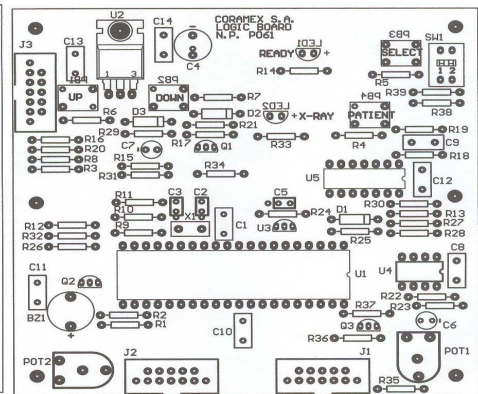

CORIX PRO 70  
LOGIC BOARD LAYOUT  
ASSY PN R071

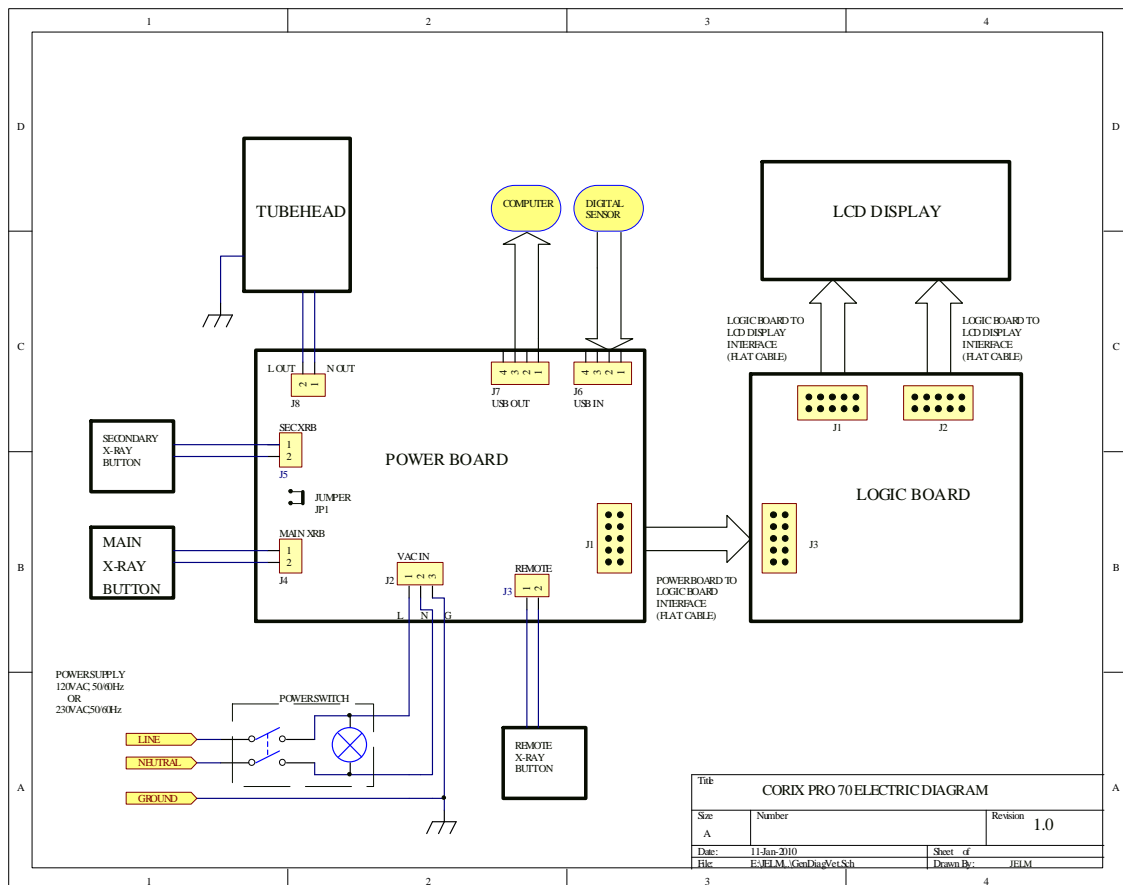

**CORAMEX, S.A.**  
**A Division of CORIX MEDICAL SYSTEMS**  
**Lauro Villar No. 94-B, 02440 Mexico, D.F.**  
**Mexico.**  
**Tel. +52-55-5394-1199**  
**Fax +52-55-5394-8120**  
[www.corix.us](http://www.corix.us)

**EXCLUSIVE AGENT FOR THE U.S.A.:**  
**Chicago X-Ray Systems, Inc.**  
**Tel. (847) 459-3889, (800) 870-2792**  
**Fax (847) 459-9214**  
[chicagoxray@yahoo.com](mailto:chicagoxray@yahoo.com)  
[www.chicagox-ray.com](http://www.chicagox-ray.com)

**Corix PRO 70**  
**Installation & User's Manual**  
**Cat. # R140, Release 1.1, January 2010.**

**Corix, and: Corix Medical Systems are Registered Trademarks of Coramex, S.A.**