

# Receptor Corujão 433Mhz

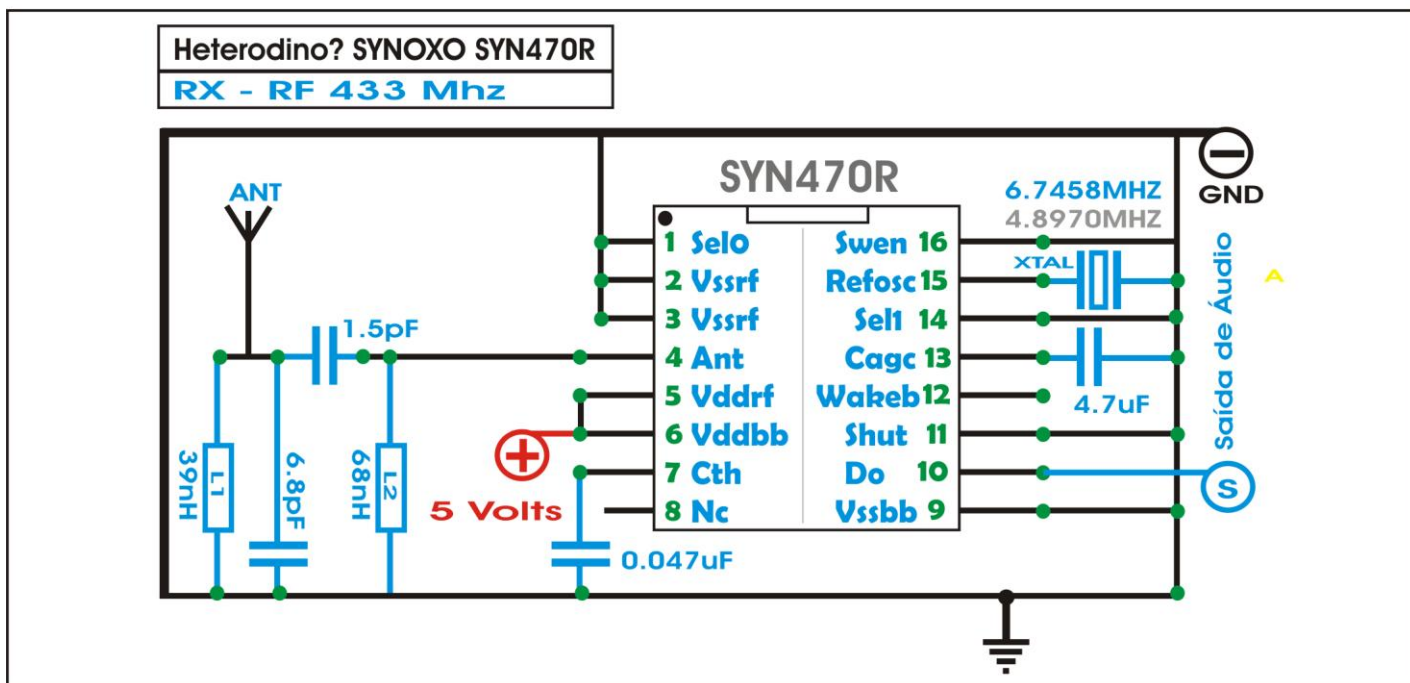
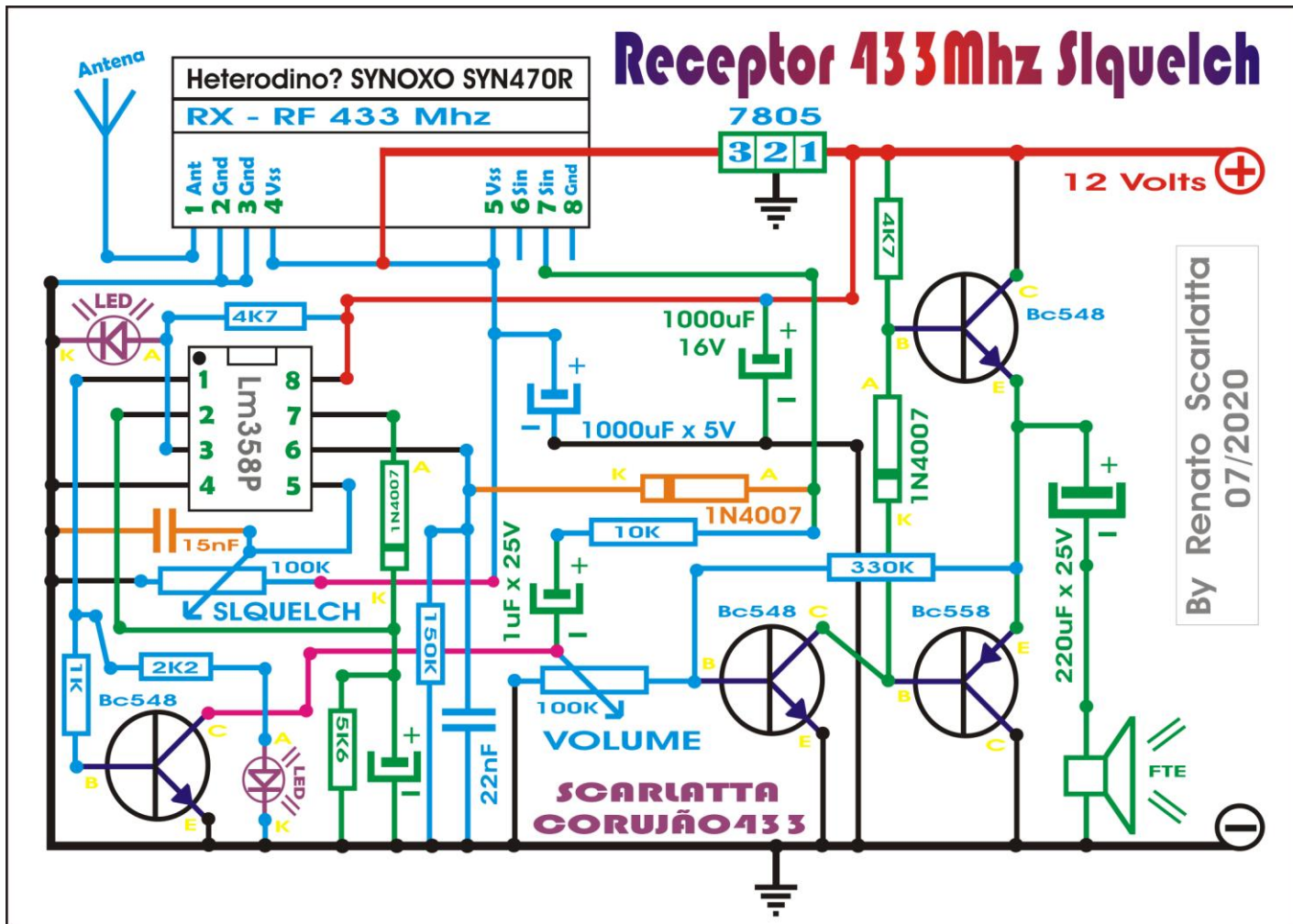

Link dos Vídeos:

Teste no receptor: <https://www.youtube.com/watch?v=Fwoqp8v8kVI>

Link de downloads do circuito eletrônico: <https://drive.google.com/file/d/170AASDKUGAFQZGjvXAS49UX3da9NIEI7>

Circuito elaborado por Renato Scarlatta, com intuito de testes e estudos.

scarlatta@outlook.com.br