

MANUAL DE SERVIÇO

TELEVISORES LED

MODELOS : DL3277i(A)W / DL3977i(A)F / DL3975i(A)W

ESPECIFICAÇÕES

Tensão de rede: ----- 110 - 220V ~ (60 Hz) automático.

Consumo -----DL3277i(A)W ----- Stand by ----- < 1,0 Watt
 Médio ----- 44 Watts
 DL3977i(A)F ----- Stand by ----- < 1,0 Watt
 Médio ----- 65 Watts
 DL3975i(A)W ----- Stand by ----- < 1,0 Watt
 Médio ----- 65 Watts

Sintonizador Analógico / Digital

Impedância de entrada de antena:----- 75 ohm-tipo desbalanceada para VHF/UHF

Impedância de entrada de cabo:----- 75 ohm-tipo desbalanceada para CABO

Sintonizador:----- Circuito de recepção discreto

Sistema de sintonia----- F.S. (Frequency synthesizer)-PLL

Sistema de televisão:----- Padrão M -525 linhas

Faixa de frequência de recepç 54M Hz a 864 MHz

Frequência intermediária (sinal digital):----- 44M Hz

Frequências intermediárias (sinal analógico):---Portadora de vídeo----- 45,75 MHz

Portadora de som ----- 41,25 MHz/ 4,5M Hz

Portadora de crom a----- 42,17 MHz

freqüências subportadoras de crom a (sinal analógico):----- 3,575611M Hz ---- (PALM)

3,582056 M Hz ---- (PALN)

3,579545 M Hz ---- (NTSC)

Potência de áudio (com sinal de entrada: -10dBm ou 600mVrms)---- 7.5W + 7.5W (RMS) / 8 ohms

Painel DL3277i(A)W

Código ----- RDL320HY(LD0-201) - Skyworth

Tipo: ----- TFT - Direct - LED

Resolução ----- 1366 x 768 pixels

Cor: ----- 16.7M (8bit/color)

Angulo de visão: ----- H:176°,V:176° (tip.)

Tempo de resposta: ----- 9 mseg

Taxa de contraste: ----- 1200:1 (min.)

Brilho: ----- 250 cd/m²

Painel DL3977i(A)F

Código ----- RDL390FY(QD0-301) - Skyworth

Tipo: ----- TFT - Direct - LED

Resolução ----- 1920 x 1080 pixels

Cor: ----- 16.7M (8bit/color)

Angulo de visão: ----- H:176°,V:176° (tip.)

Tempo de resposta: ----- 8 mseg

Taxa de contraste: ----- 3000:1 (min.)

Brilho: ----- 280 cd/m²

Painel DL3975i(A)W

Código ----- RDL390HY(QD0-301) - Skyworth

Tipo: ----- TFT - Direct - LED

Resolução ----- 1366 x 768 pixels

Cor: ----- 16.7M (8bit/color)

Angulo de visão: ----- H:176°,V:176° (tip.)

Tempo de resposta: ----- 8.5 mseg

Taxa de contraste: ----- 3000:1 (min.)

Brilho: ----- 280 cd/m²

Peso/ Dimensões(LxAxP):-----DL3277i(A)W ----- 6,24 Kg (c/ pedestal: 740 x 487 x 190 mm)

(s/ pedestal: 740 x 444 x 70 mm)

DL3977i(A)F ----- 10,36 Kg (c/ pedestal: 895 x 576 x 200 mm)

(s/ pedestal: 895 x 532 x 83 mm)

DL3975i(A)W ----- 10,36 Kg (c/ pedestal: 895 x 576 x 200 mm)

(s/ pedestal: 895 x 532 x 83 mm)

CHECAGEM

VERIFICAÇÃO DA VERSÃO DO SOFTWARE (Menu de Serviço).

Usando o Controle Remoto pressione INPUT, em seguida digite "3195". Esta opção abre o Menu de Fábrica do aparelho.

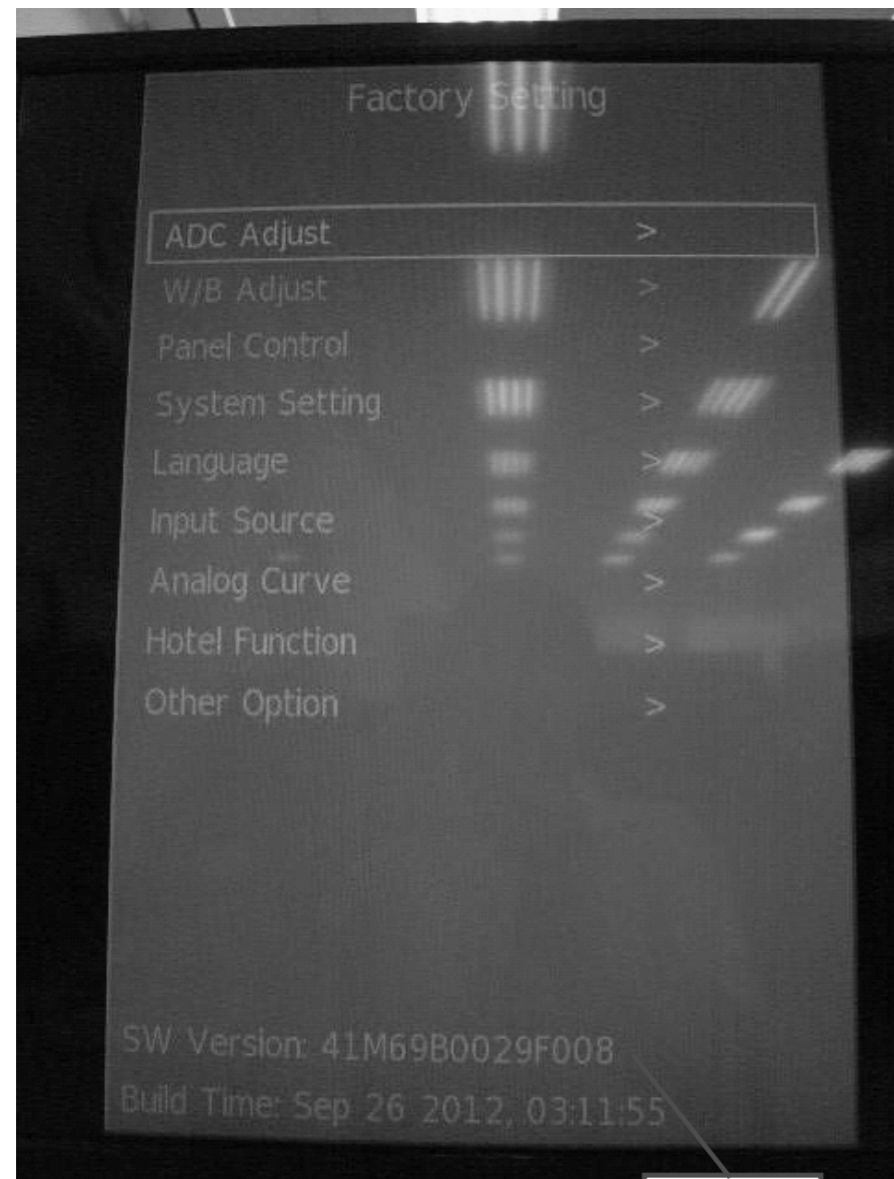

Versão do SW.
No exemplo,

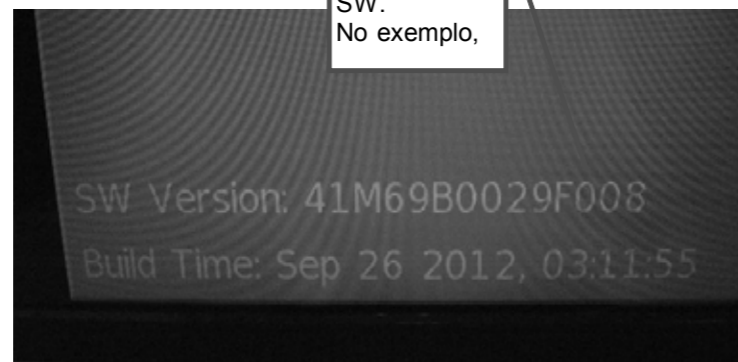

INFORMAÇÕES UTEIS

DESBLOQUEIO DO APARELHO

Caso o cliente esquecer o código de bloqueio das entradas / classificação indicativa, entre com o código "9999" para desbloquear

TECLAS DE OPERAÇÃO DO MENU DE SERVIÇO

Utilize a tecla "Enter" para acessar os menus de serviço, tecla "Menu" para voltar 1 menu anterior e teclas ∇ Δ e para selecionar ou ajustar

ATUALIZAÇÃO DE SOFTWARE (SW PRINCIPAL + MBOOT CONJUGADO)

GRAVAÇÃO DO SOFTWARE (Via USB).

1. Deverá ser gravado o software a ser instalado na raiz (Não colocá - lo em pastas ou subpastas) de um dispositivo USB.
2. Conectar o dispositivo em uma das portas USB.
3. Deixar o aparelho desligado da tomada.
4. Pressionar a tecla Menu do TV e mantendo pressionada e conectar o cabo de força na tomada.
5. O LED começará a piscar e aparecerá uma tela azul com informações sobre a atualização.

Após a atualização deve-se fazer o "Factory Reset" e após isso desligar e ligar o TV da energia elétrica.

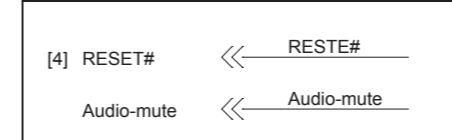
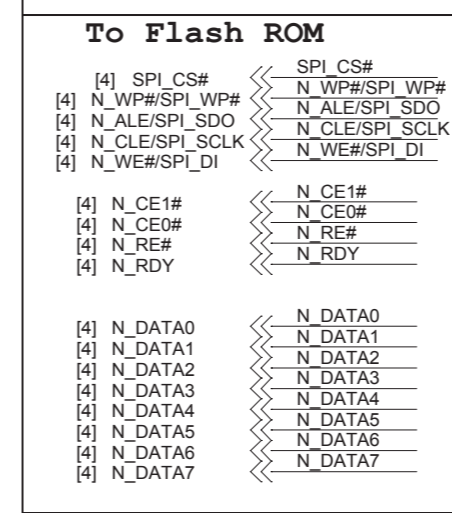
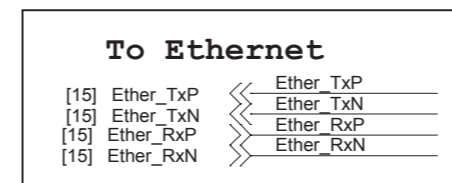
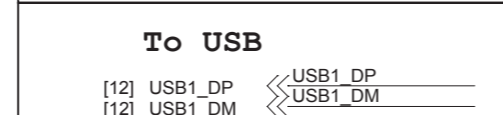
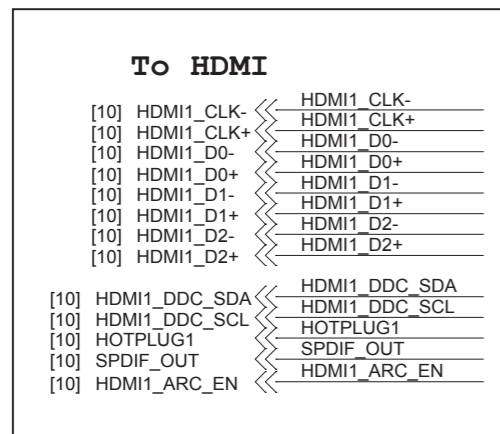
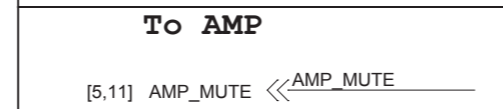
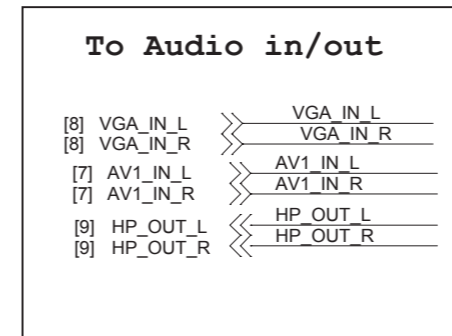
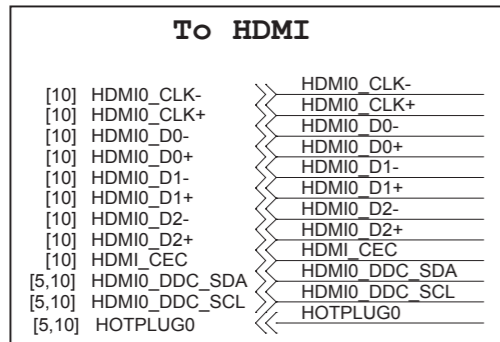
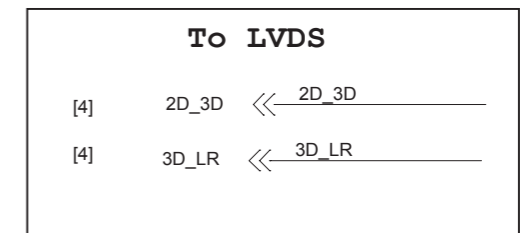
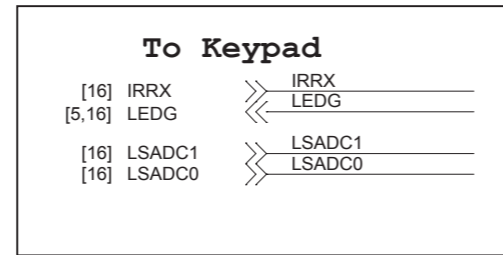
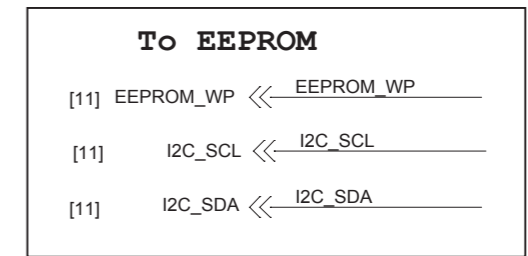
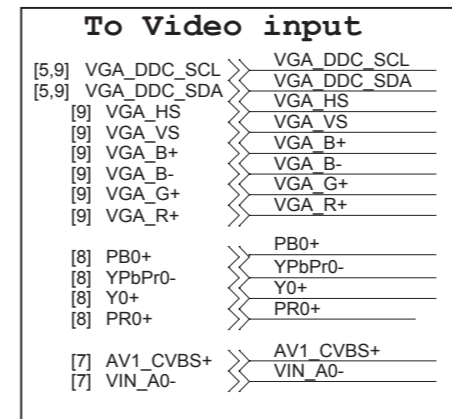
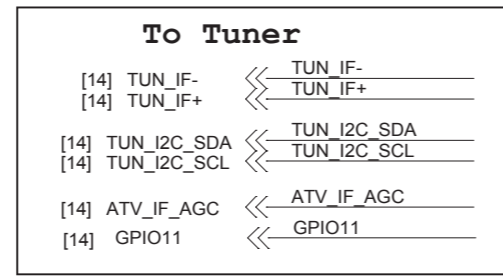
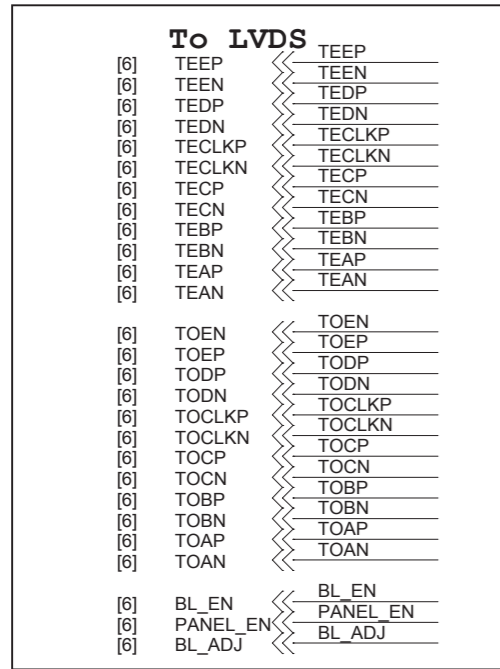

ESQUEMAS ELÉTRICOS

PCI Principal (Todos Modelos)

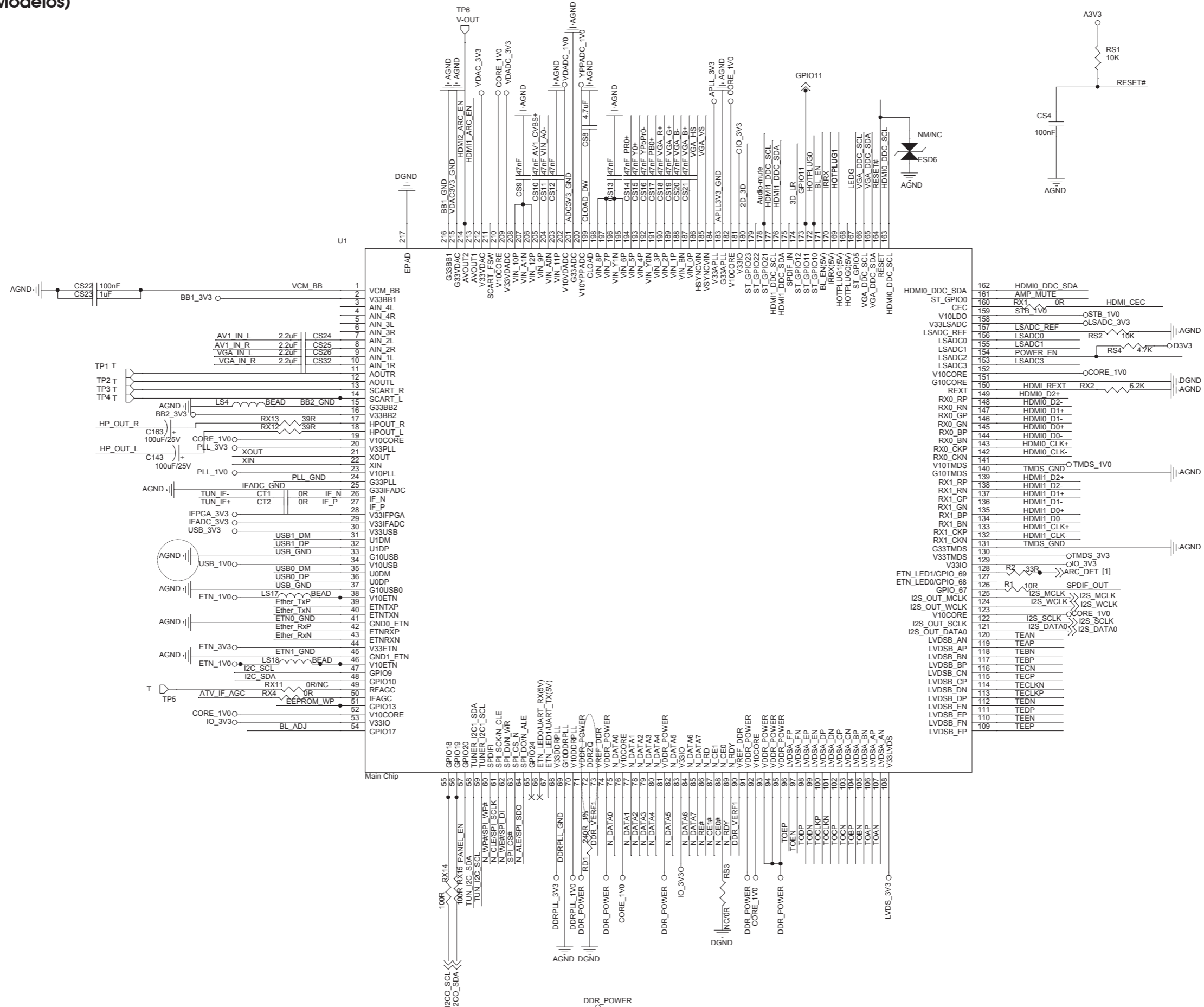

ESQUEMAS ELÉTRICOS

PCI Principal (Todos Modelos)

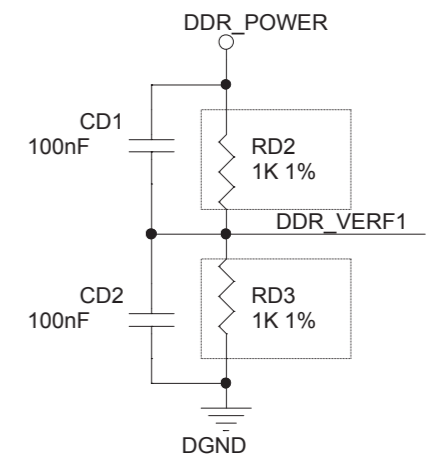
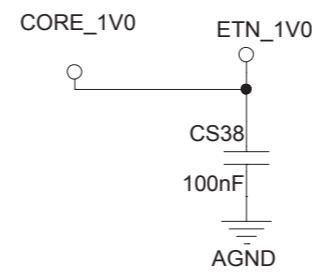
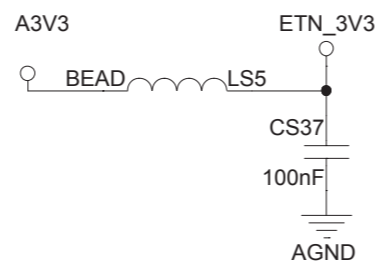
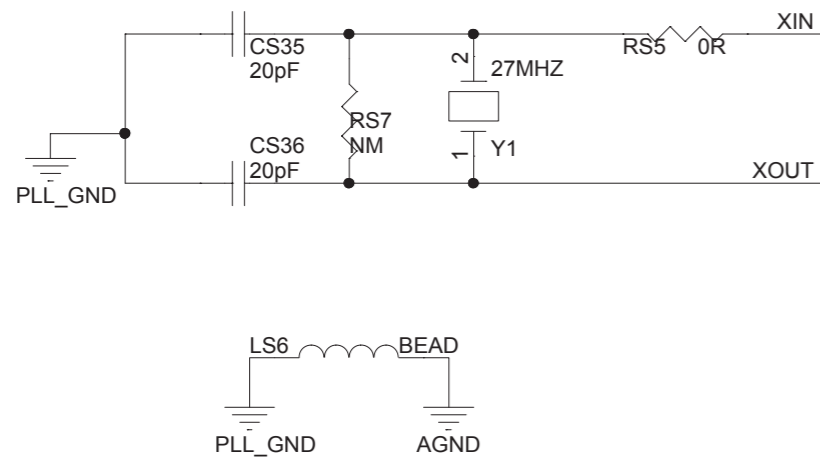
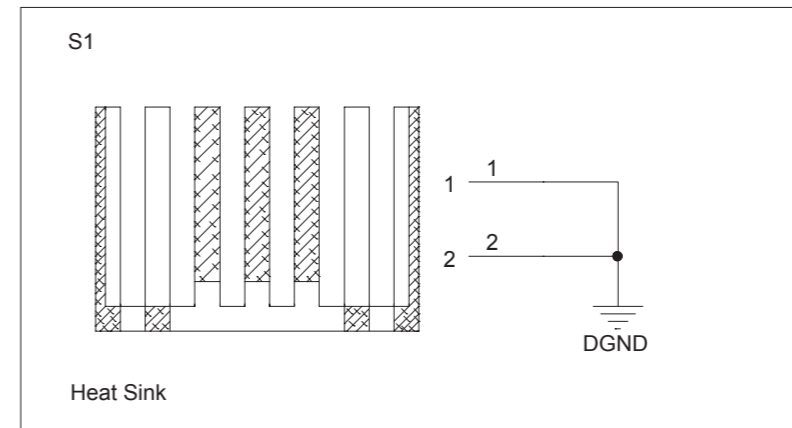
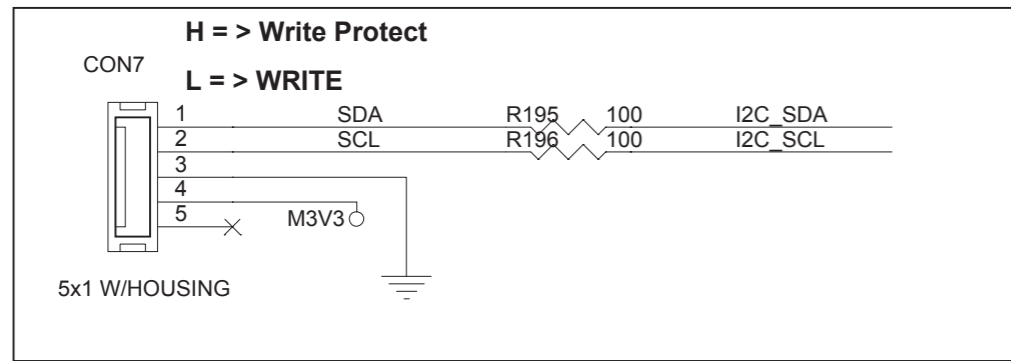

ESQUEMAS ELÉTRICOS

PCI Principal (Todos Modelos)

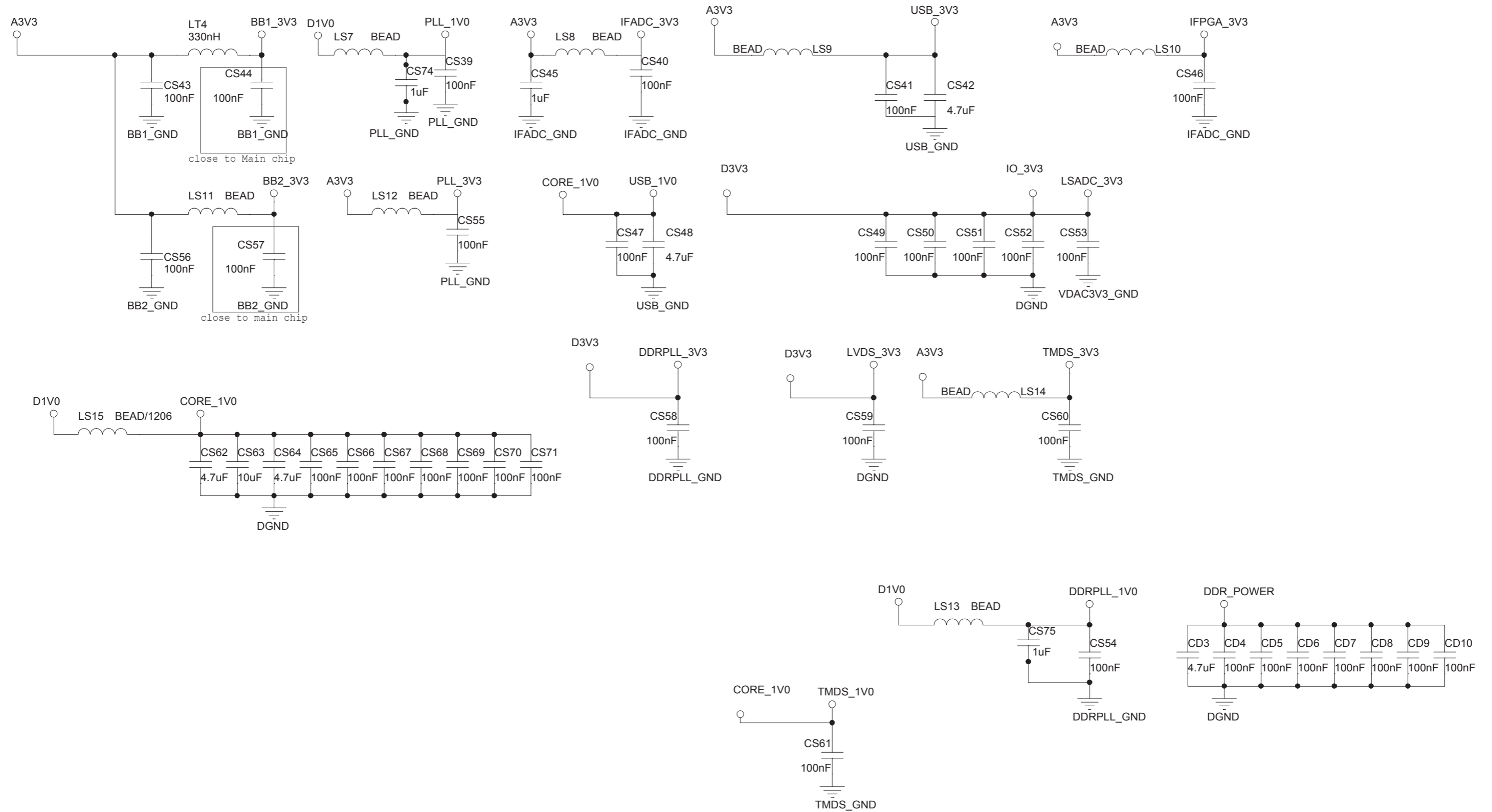

ESQUEMAS ELÉTRICOS

PCI Principal (Todos Modelos)

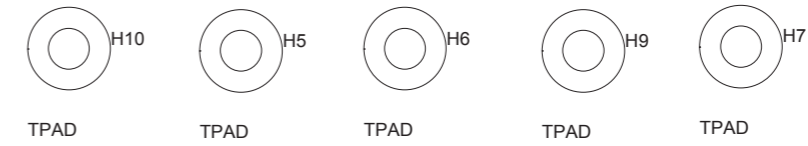
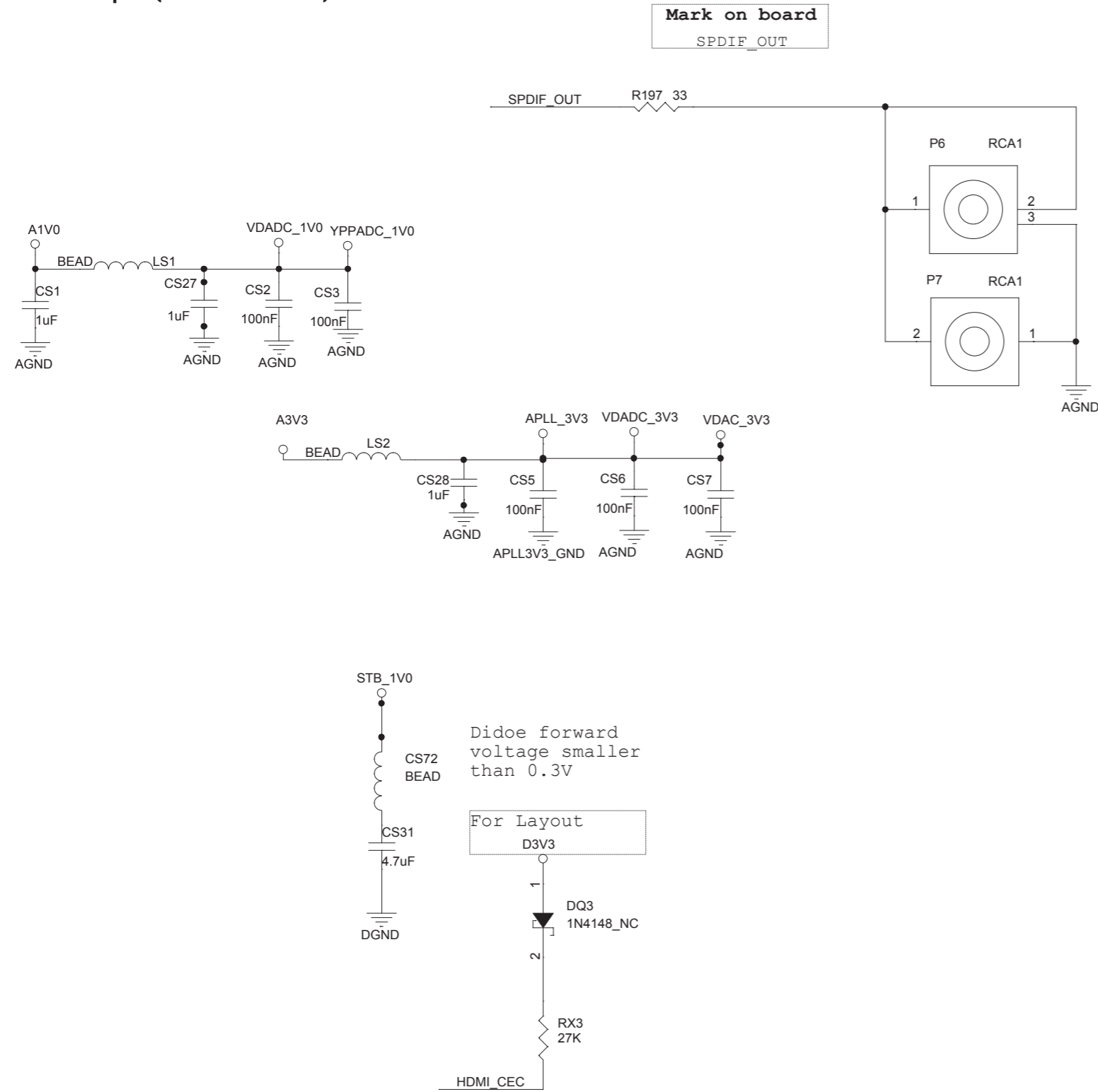

Power On Latch

Default

EJTAG (Pin 61, pull-hi)
0 : enable
1 : disable

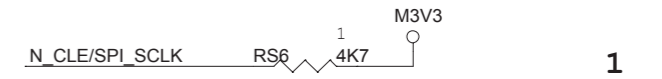

ROM boot (Pin 63, pull-lo)
0 : boot from ROM
1 : don't boot from ROM

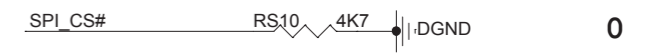

BOOT MODE bit1 (pin 64, pull-lo)
0 : SPI-Flash boot
1 : NAND-Flash boot

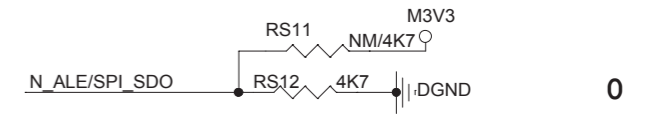

test mode (Pin 161, pull-hi)
0 : enable
1 : disable

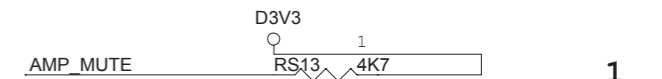

NAND access type (Pin77)
0 : Sequence mode
1 : random mode

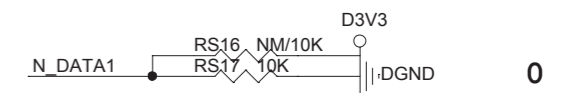

NAND ECC type (Pin75)
0 : 6 bit
1 : 12 bit

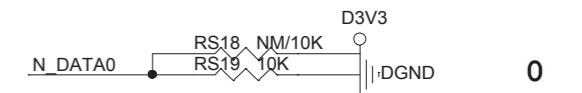

ESQUEMAS ELÉTRICOS

PCI Principal (Todos Modelos)

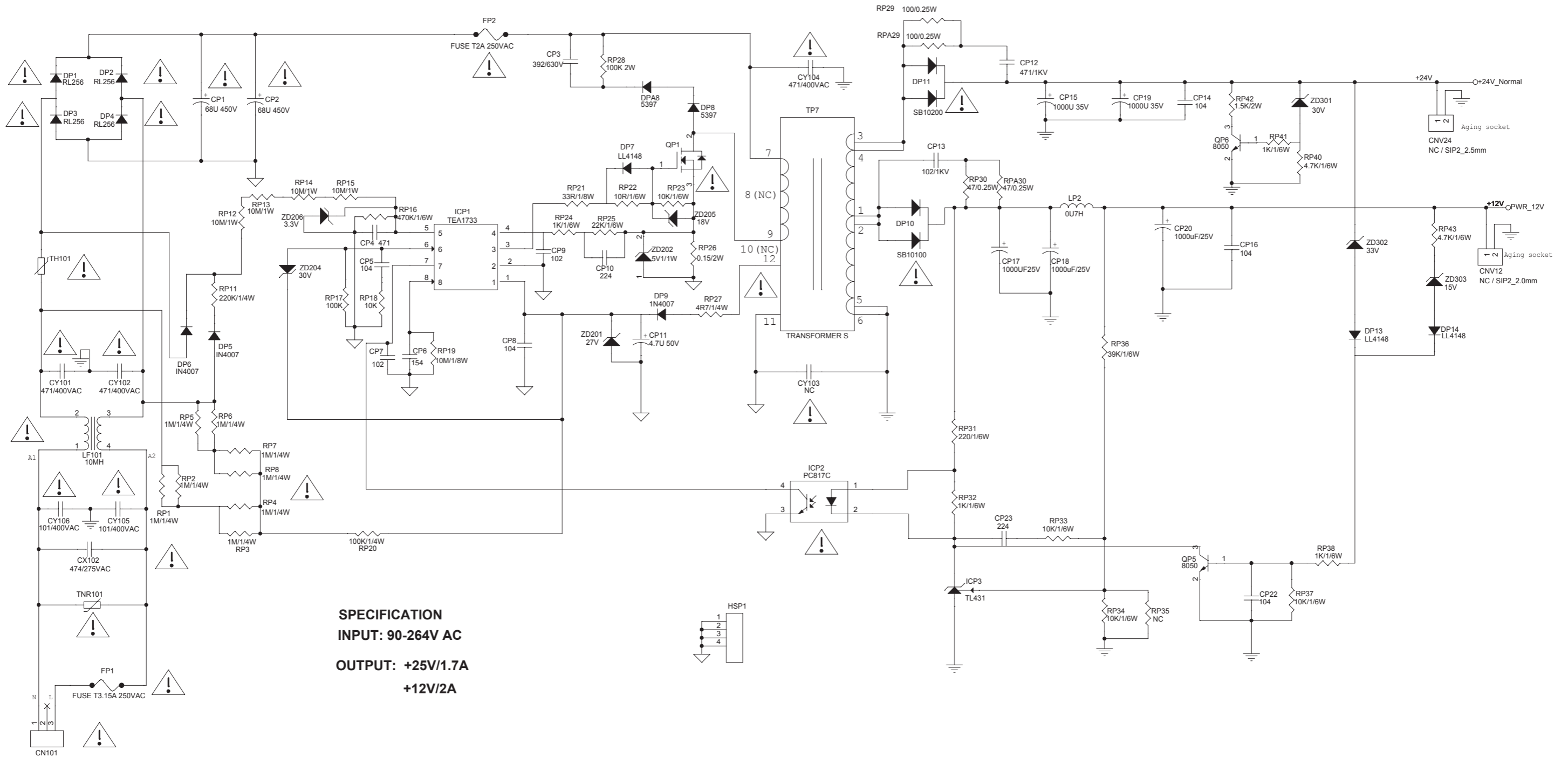

ESQUEMAS ELÉTRICOS

PCI Principal (Todos Modelos)

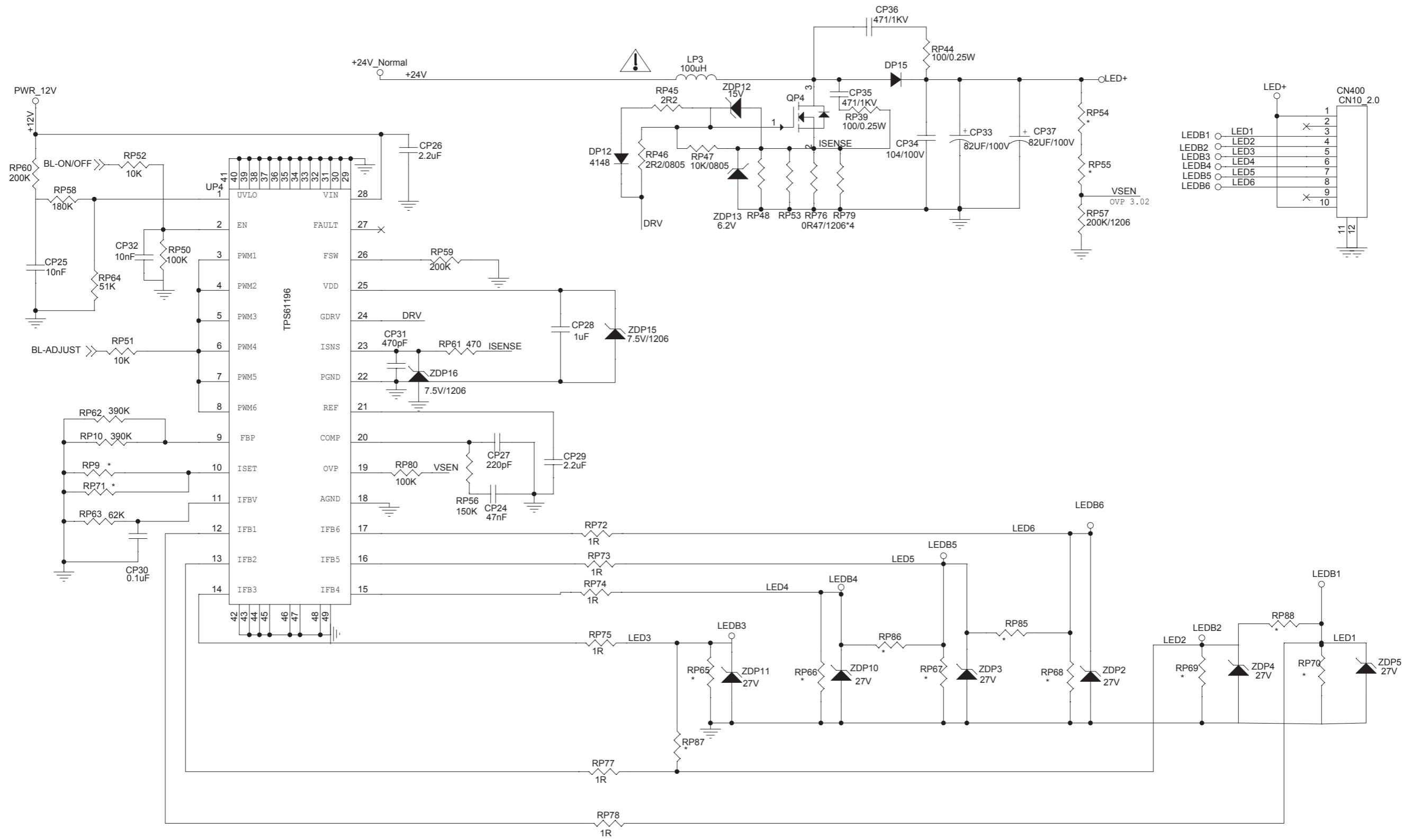

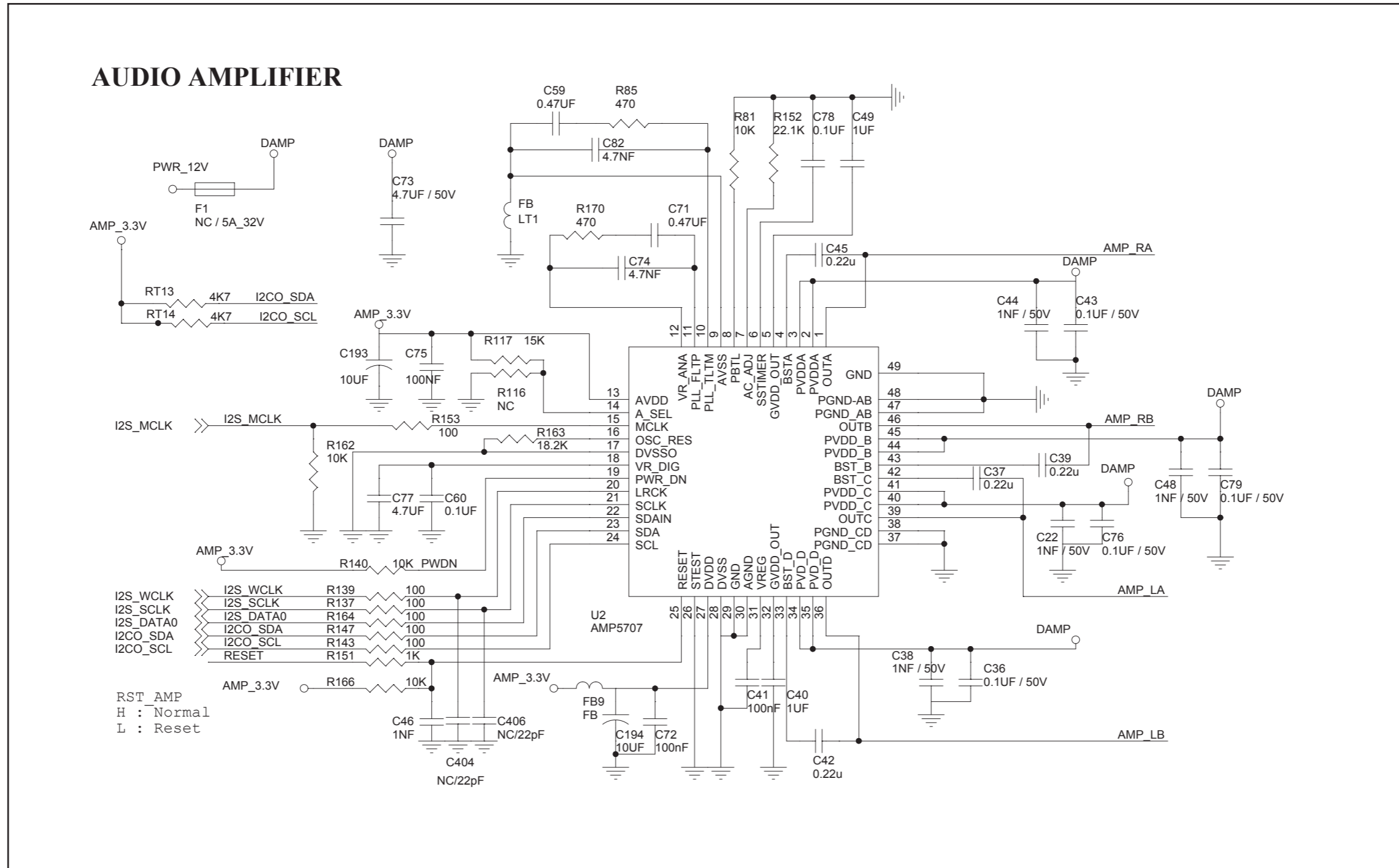

Cont. AUDIO AMPLIFIER

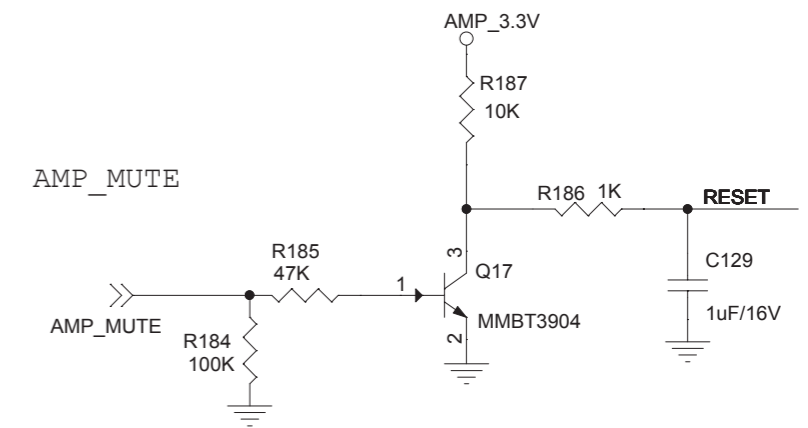
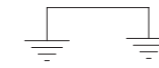
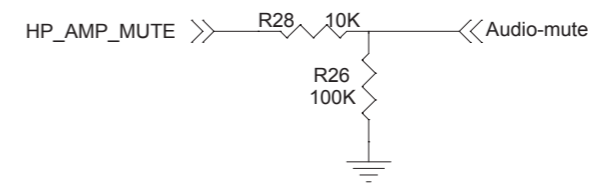
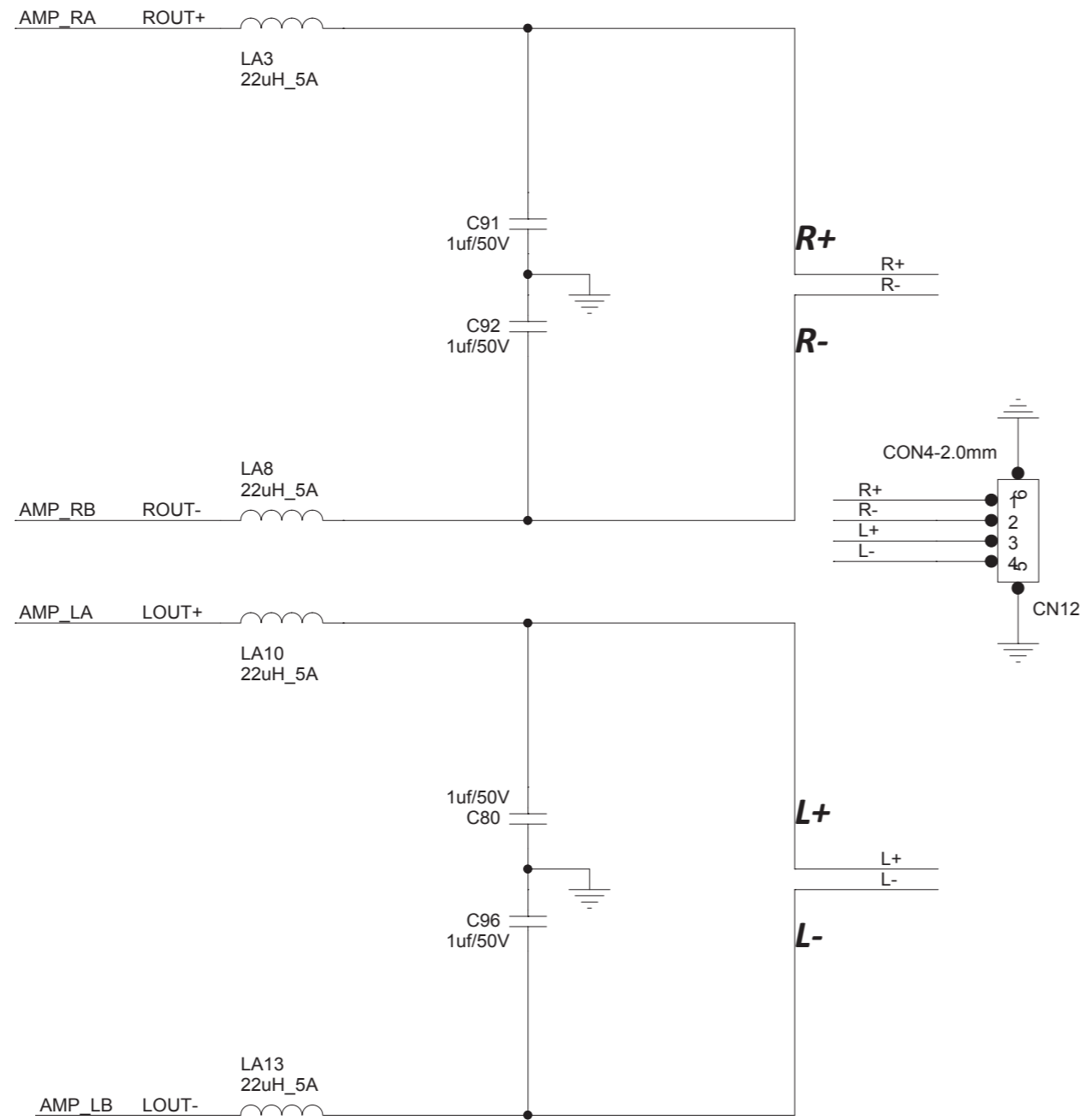

ESQUEMAS ELÉTRICOS

PCI Principal (Todos Modelos)

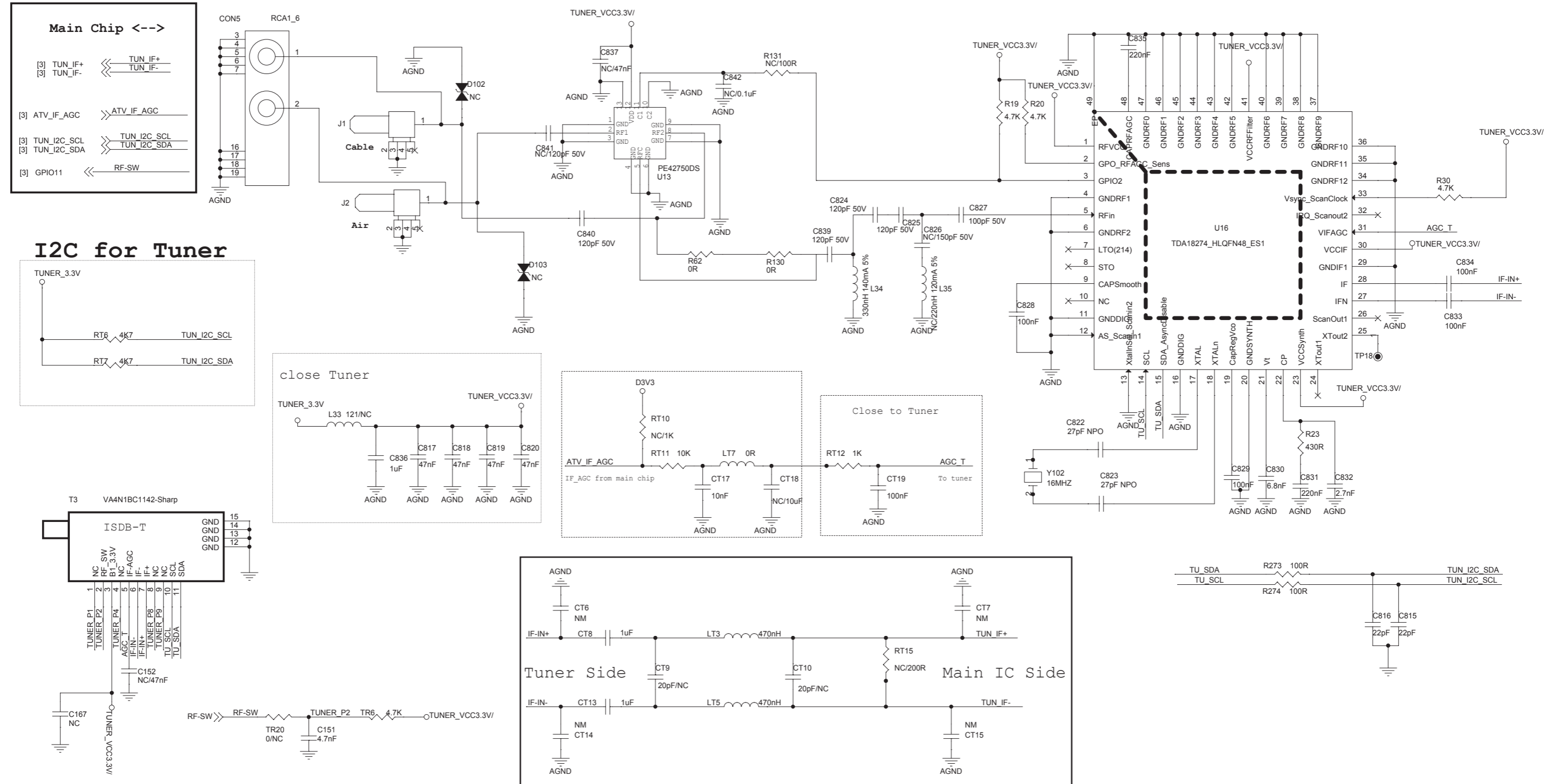

ESQUEMAS ELÉTRICOS

PCI Principal (Todos Modelos)

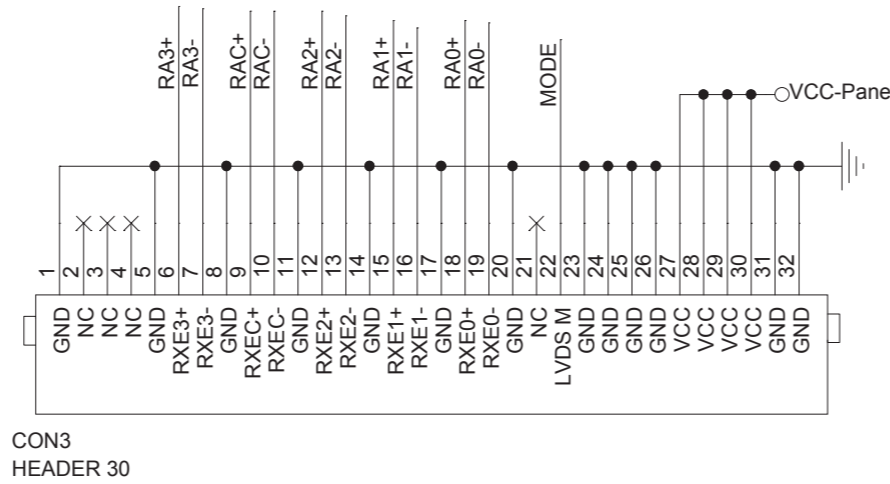
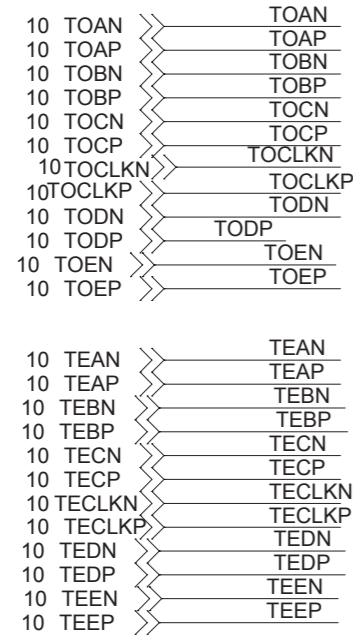
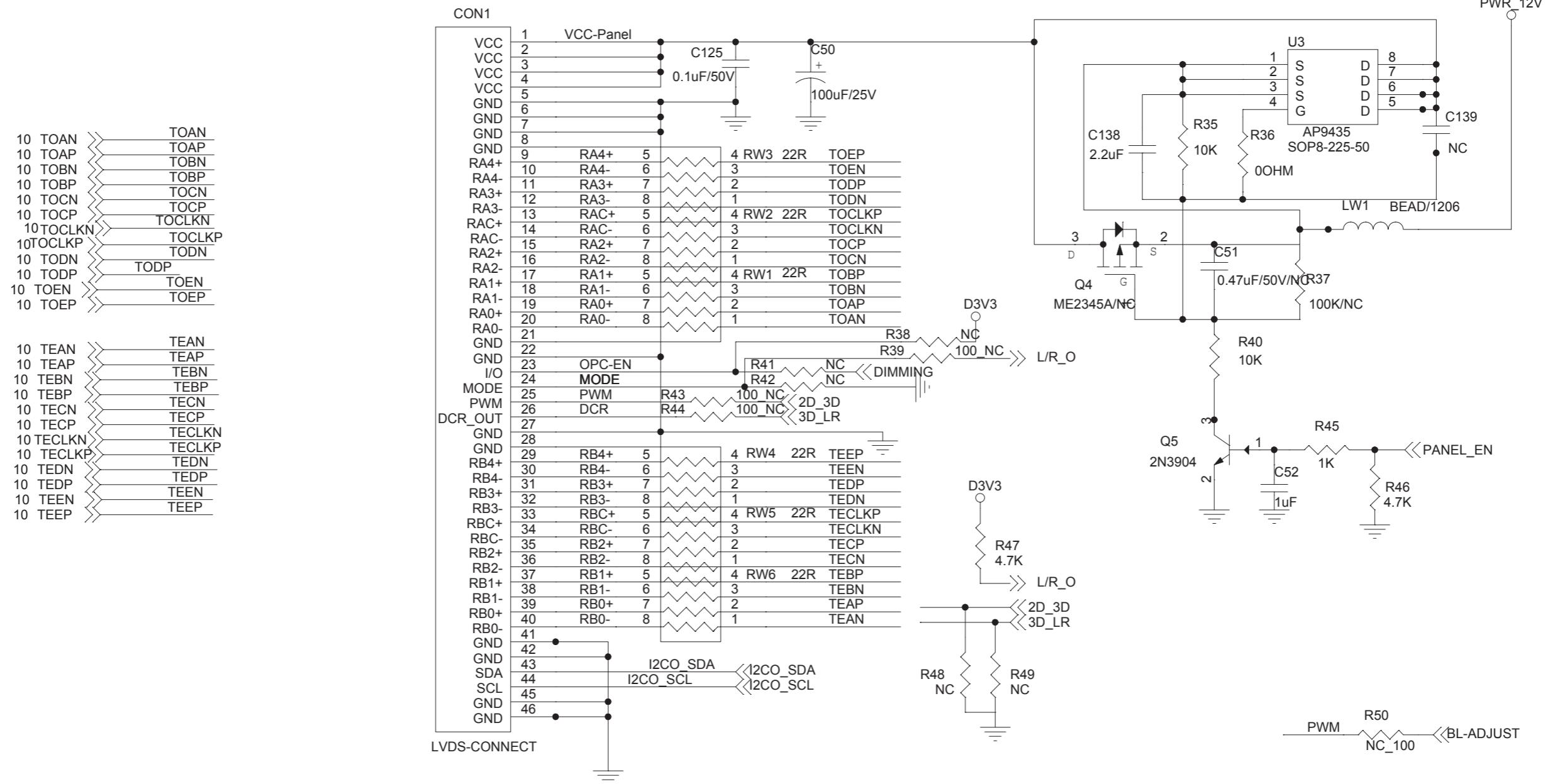

R39/R43/R44 FOR CMI 3D
 R41 FOR CMI 3D DIMMING
 R50 FOR LG BL_ADJ

DIMMING <<LSADC3

ESQUEMAS ELÉTRICOS

PCI Principal (Todos Modelos)

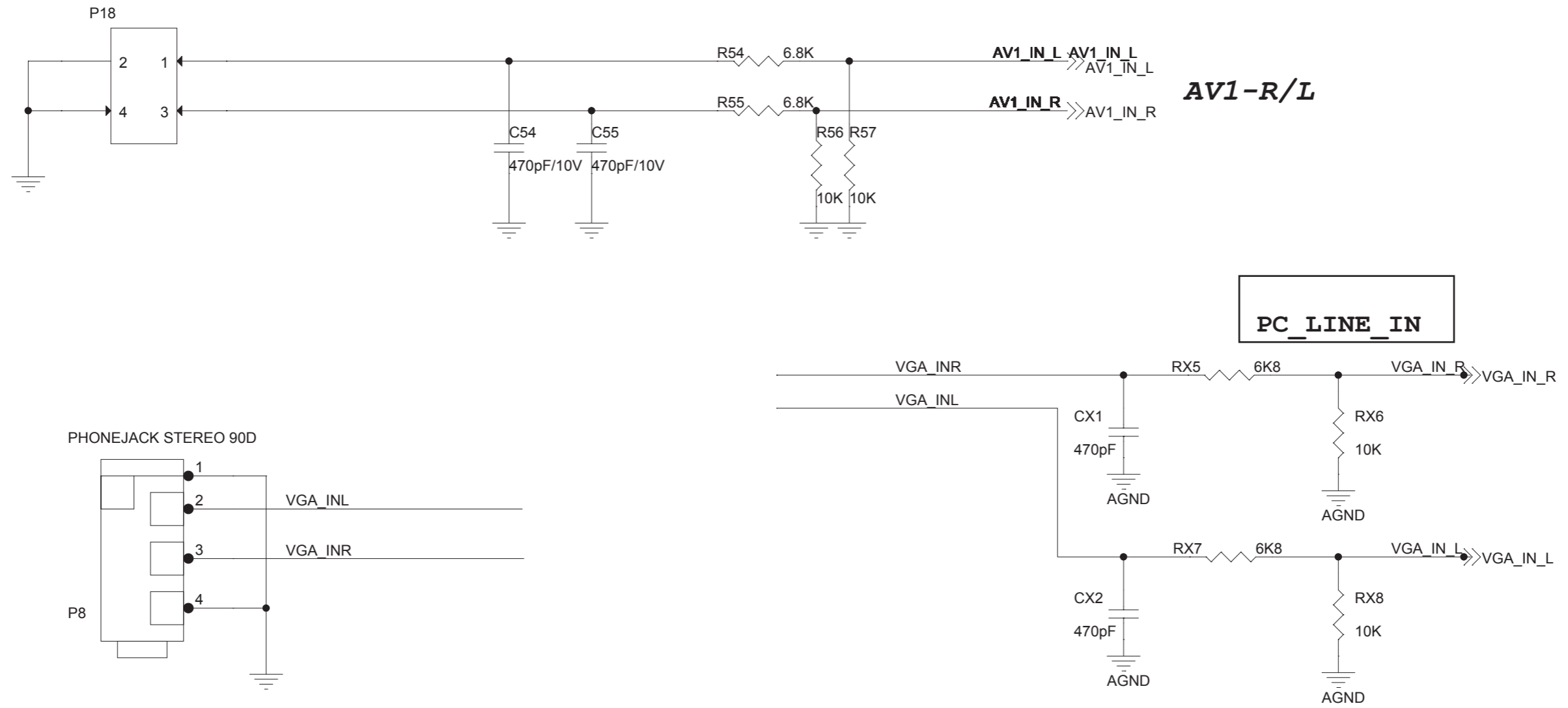

ESQUEMAS ELÉTRICOS

PCI Principal (Todos Modelos)

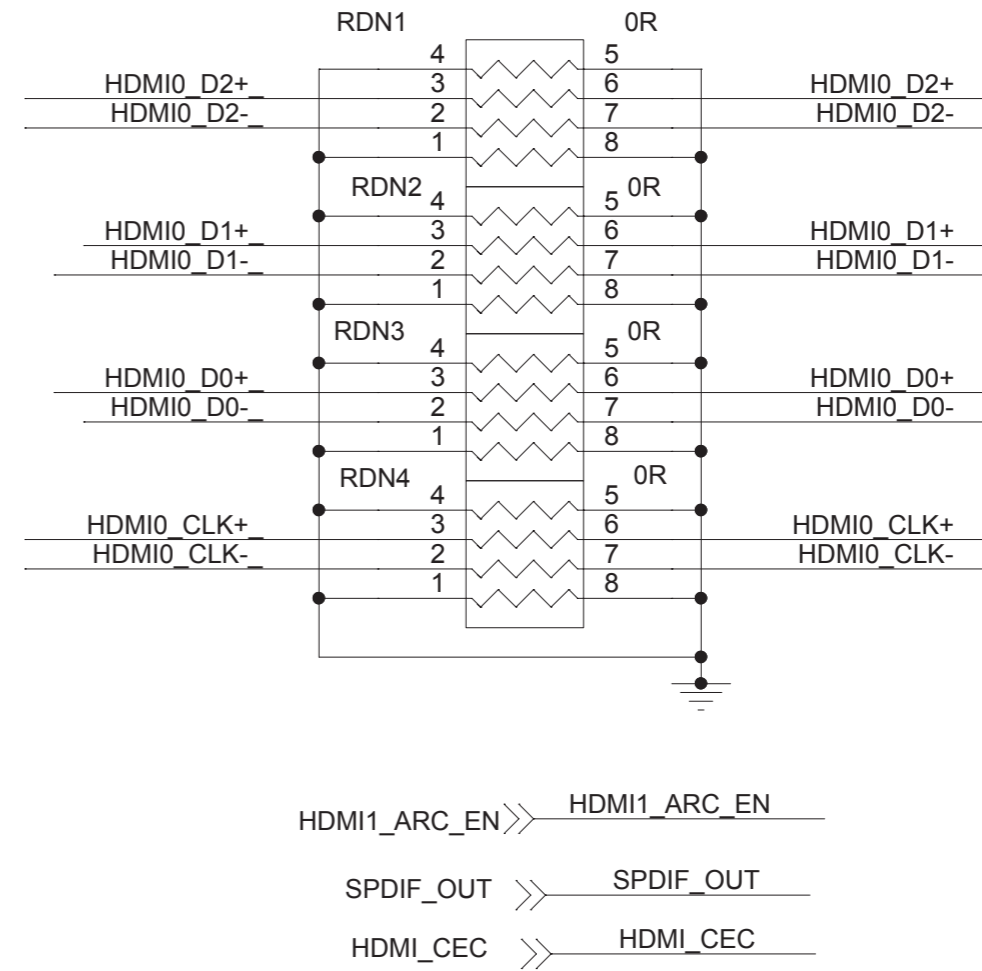
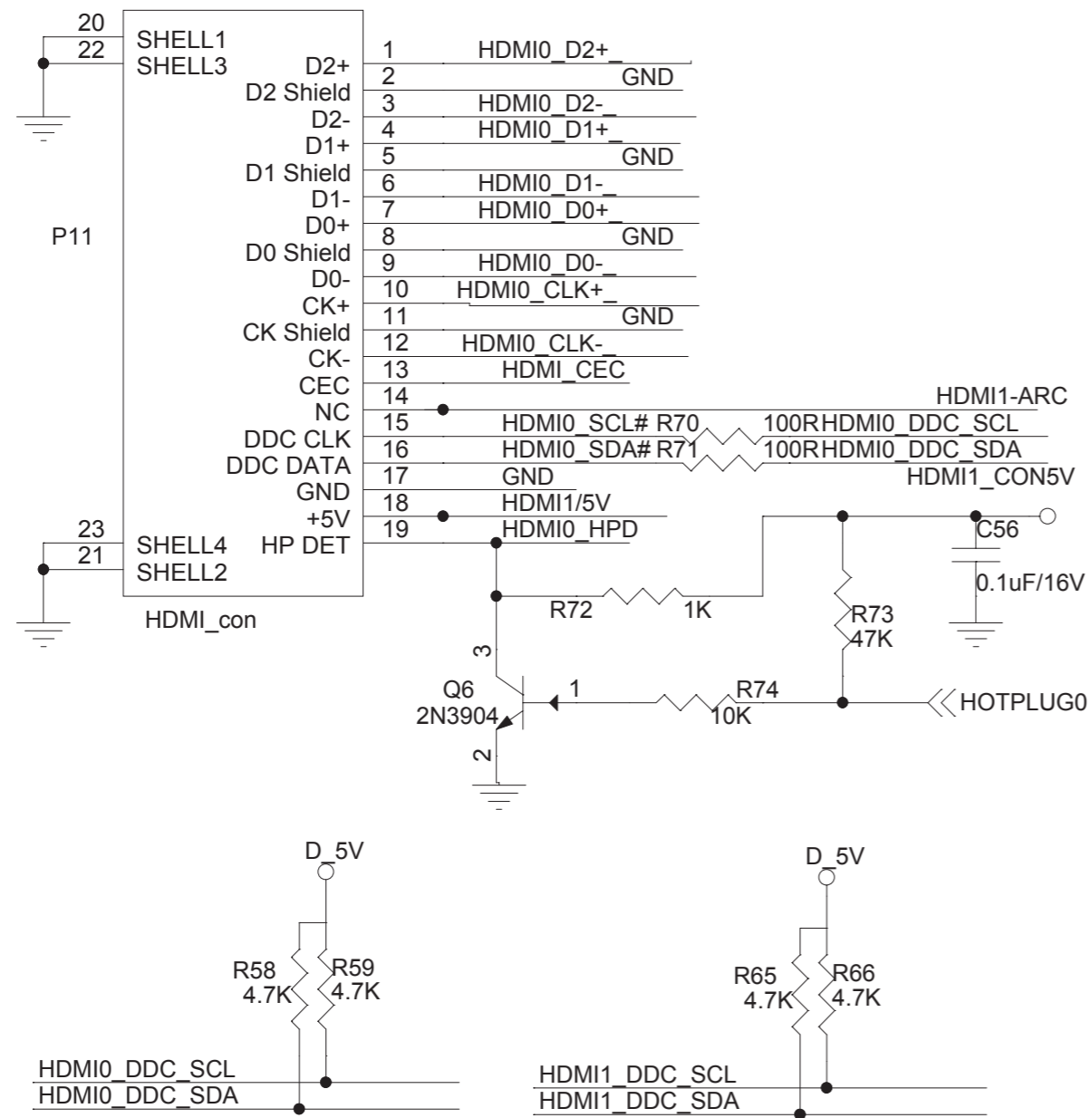

ESQUEMAS ELÉTRICOS

PCI Principal (Todos Modelos)

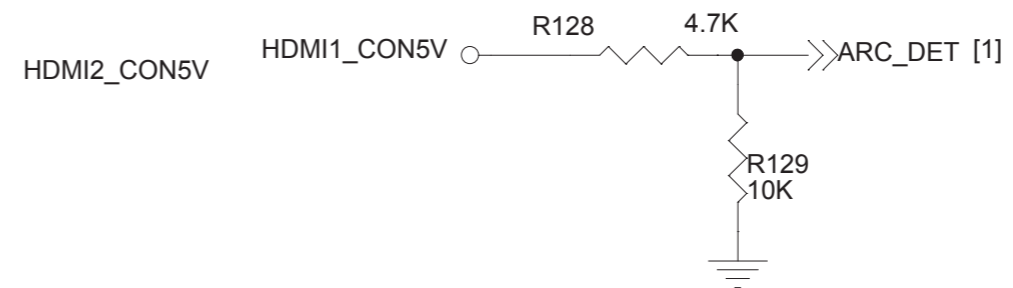
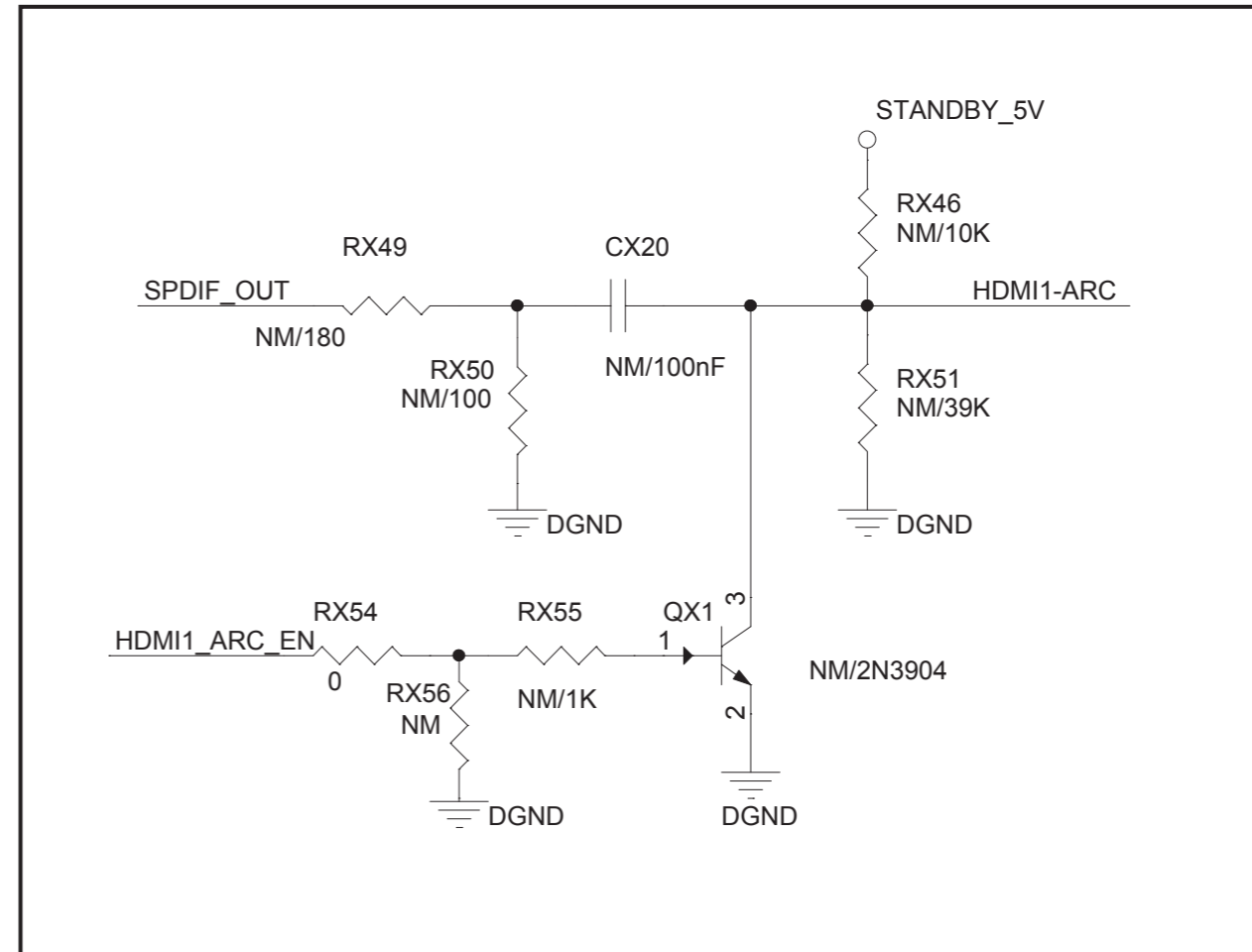
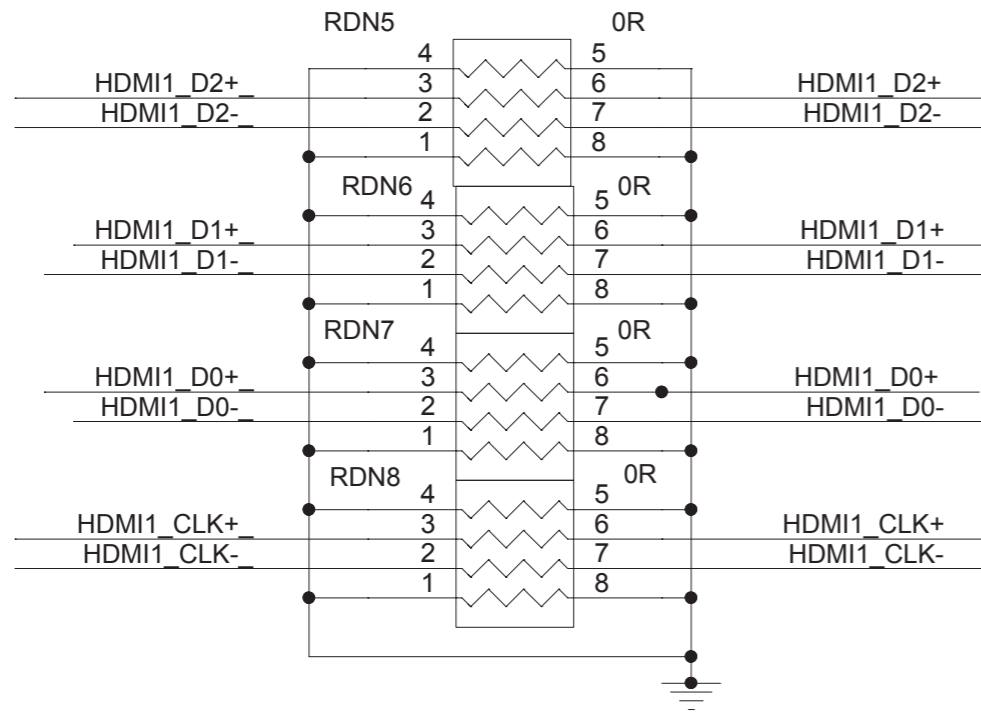

ESQUEMAS ELÉTRICOS

PCI Principal (Todos Modelos)

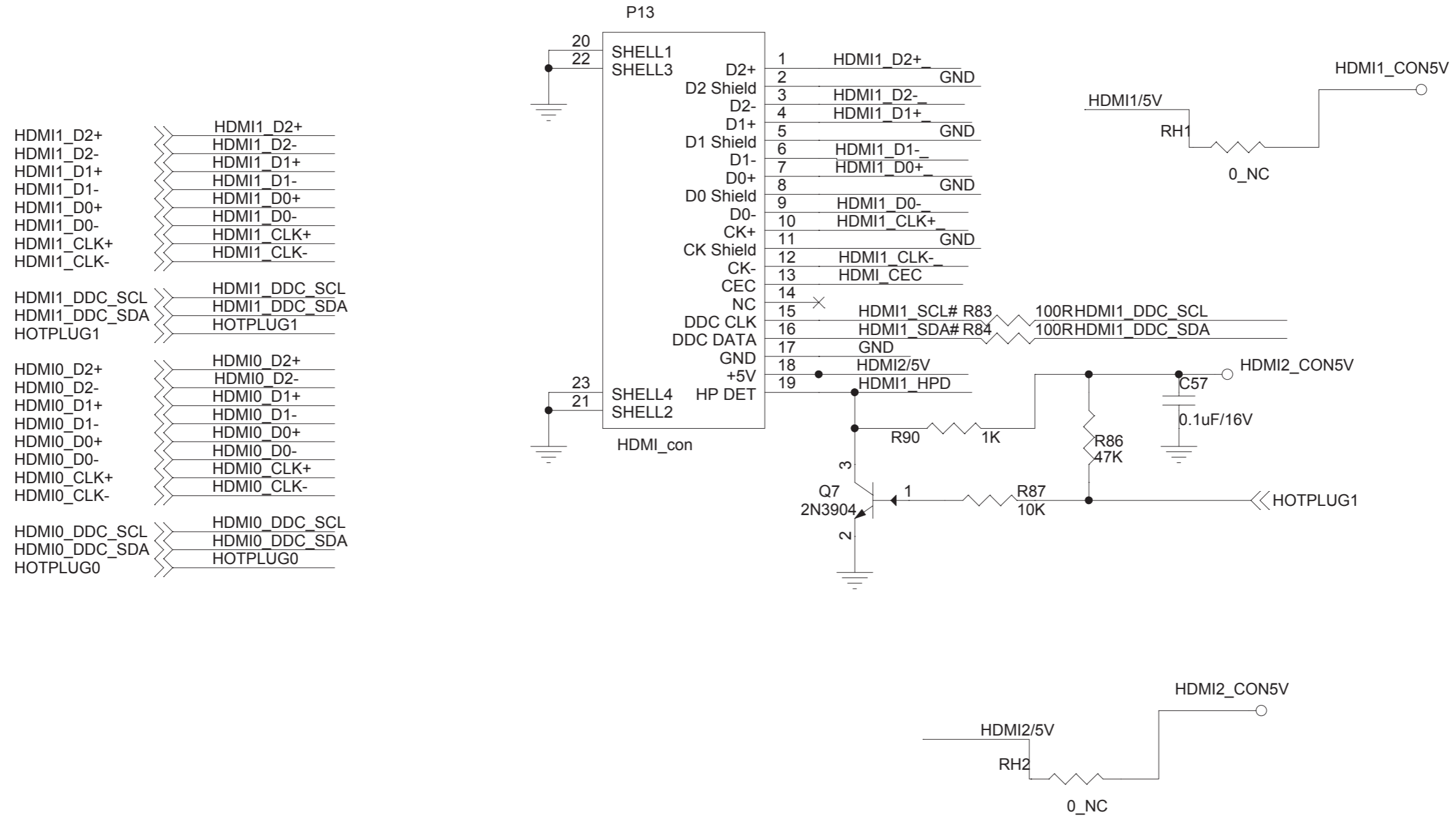

ESQUEMAS ELÉTRICOS

PCI Principal (Todos Modelos)

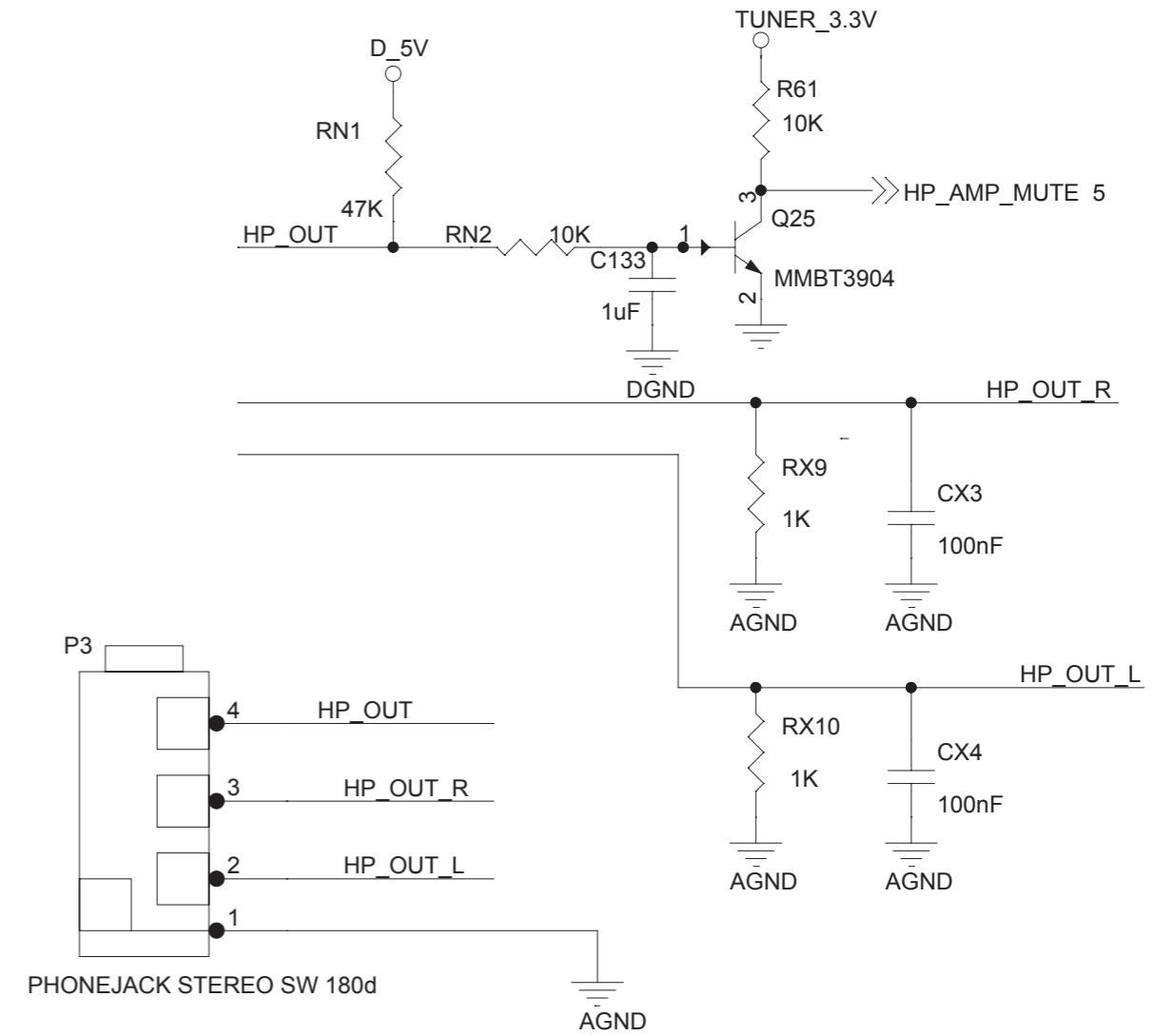
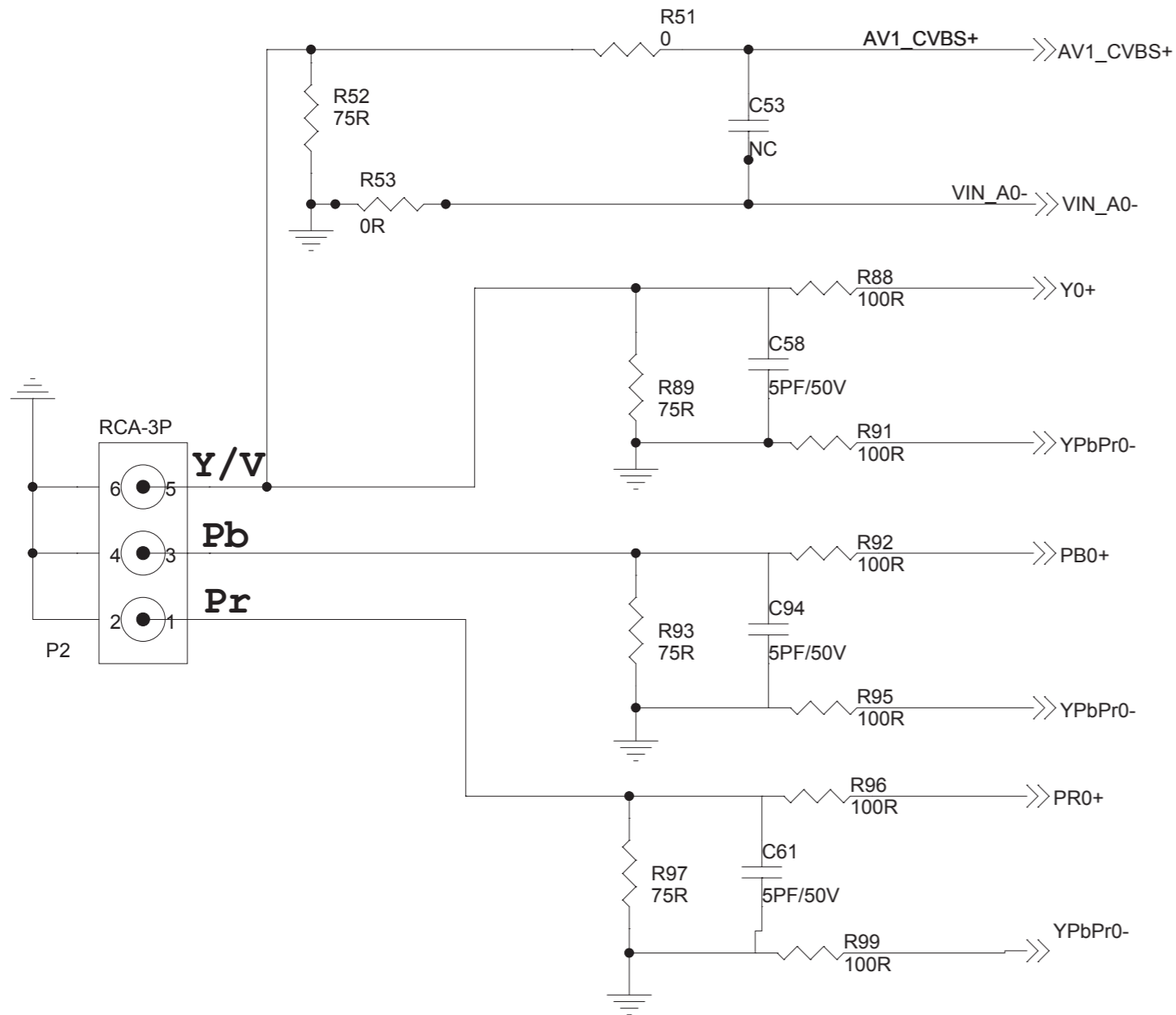

ESQUEMAS ELÉTRICOS

PCI Principal (Todos Modelos)

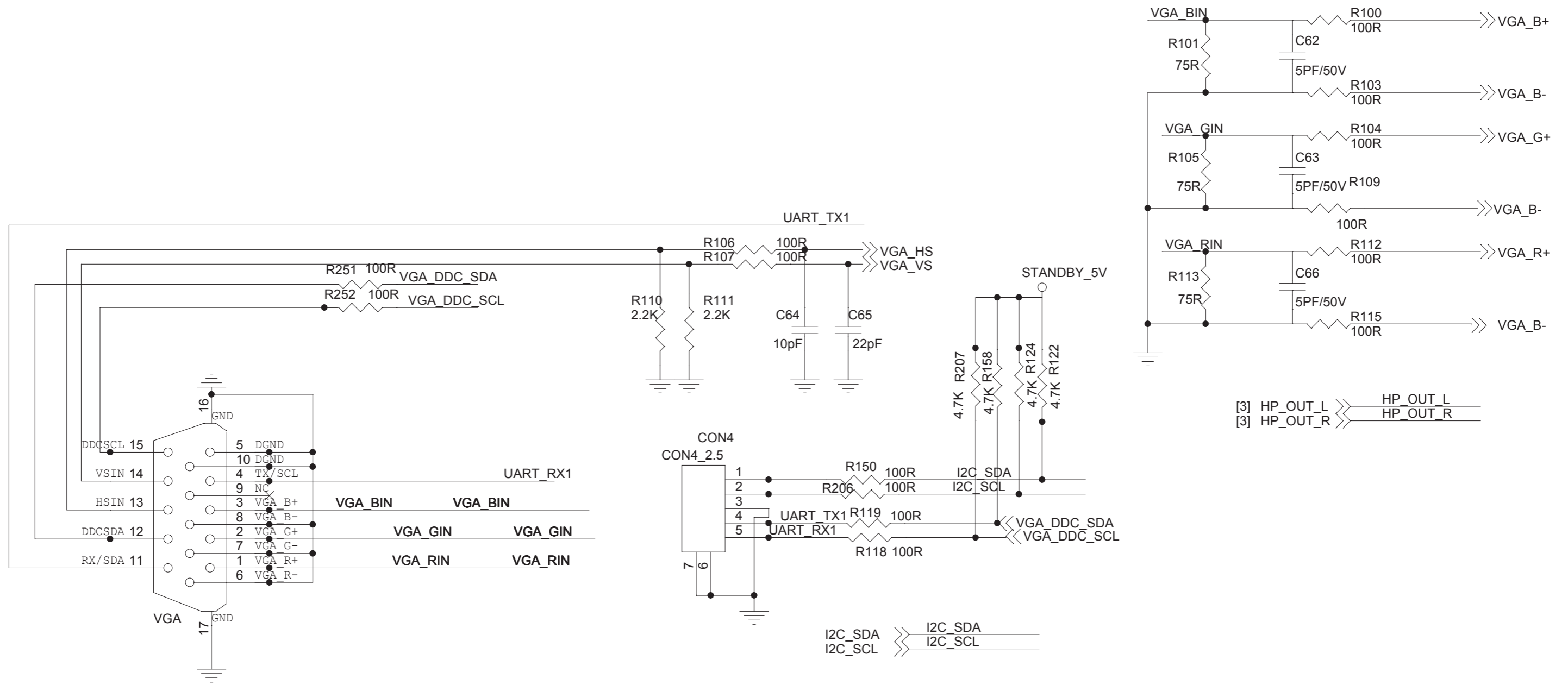

ESQUEMAS ELÉTRICOS

PCI Principal (Todos Modelos)

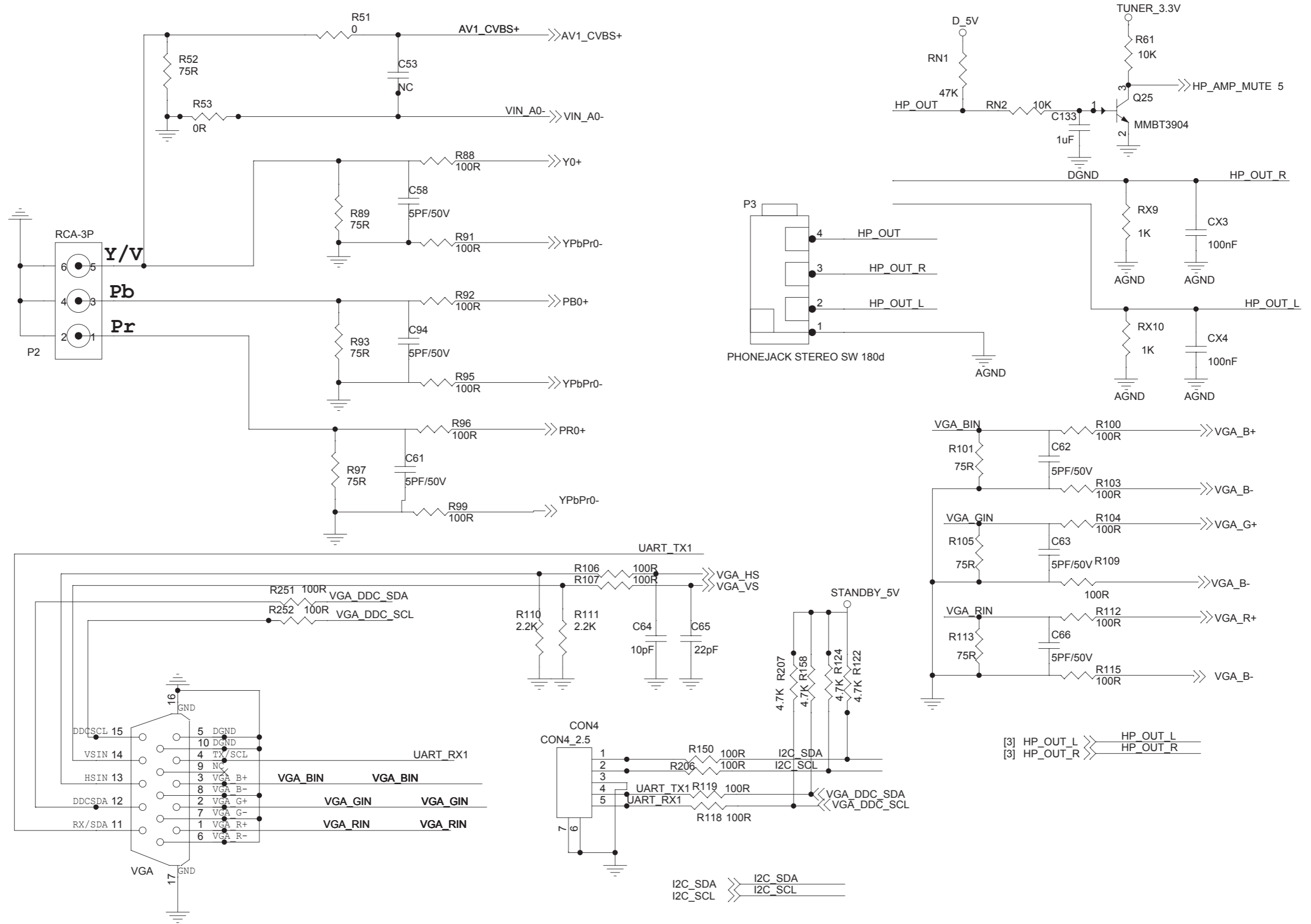

ESQUEMAS ELÉTRICOS

PCI Principal (Todos Modelos)

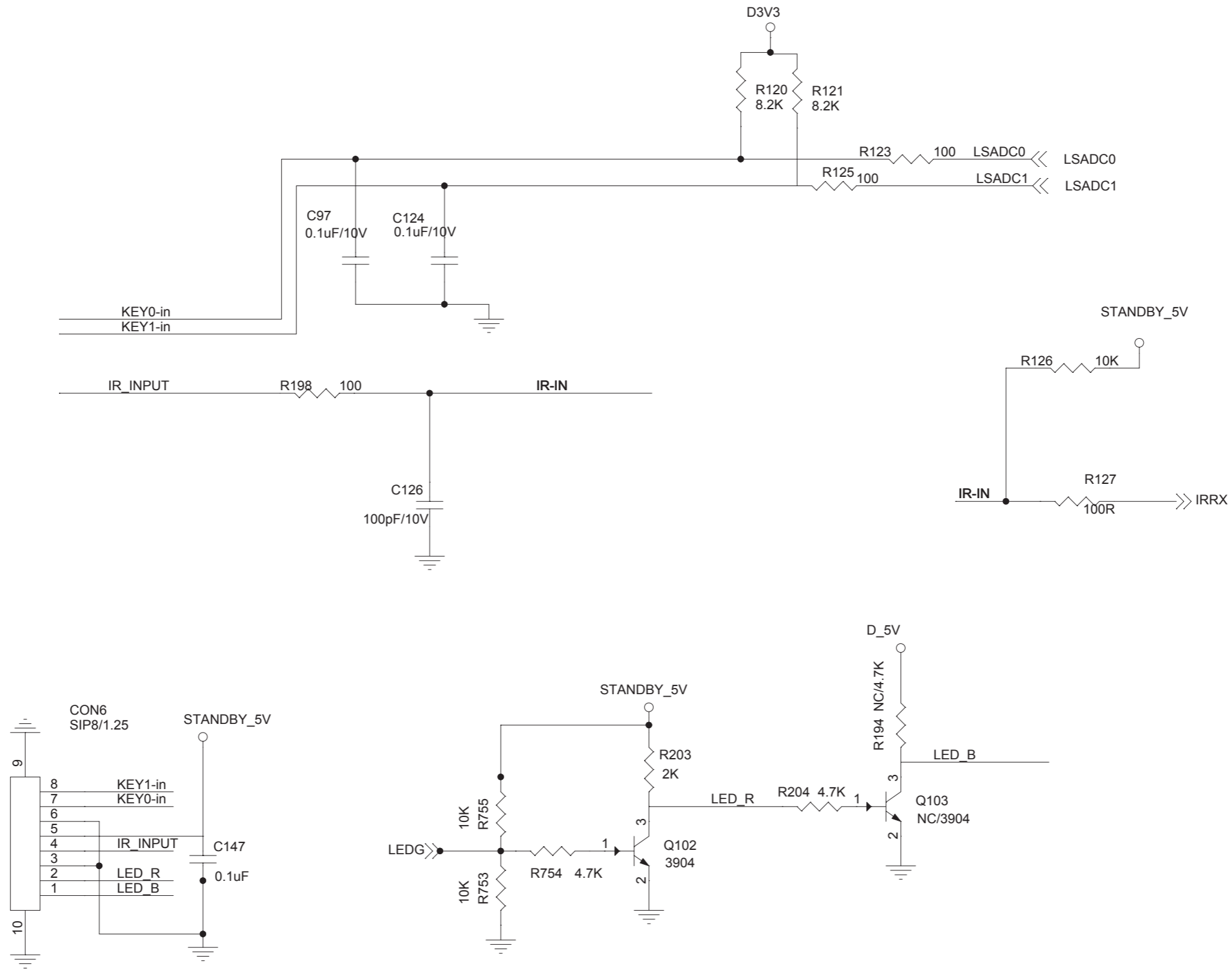

ESQUEMAS ELÉTRICOS

PCI Principal (Todos Modelos)

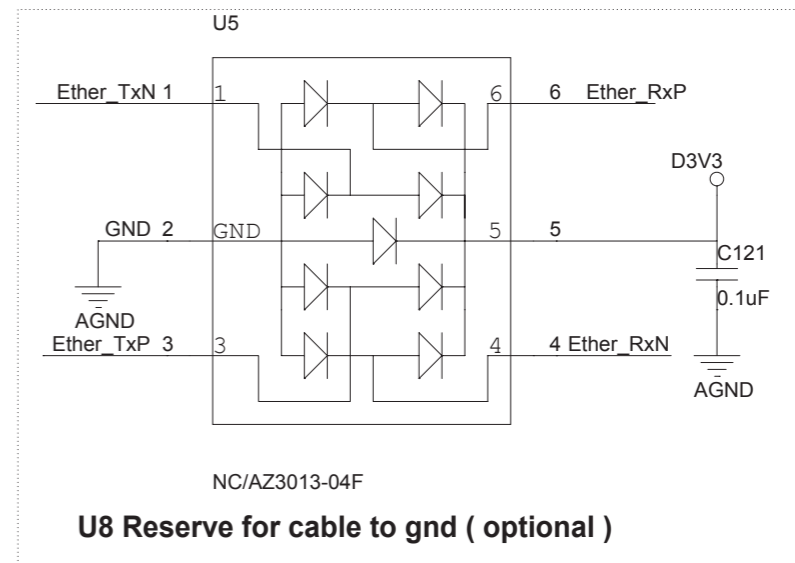
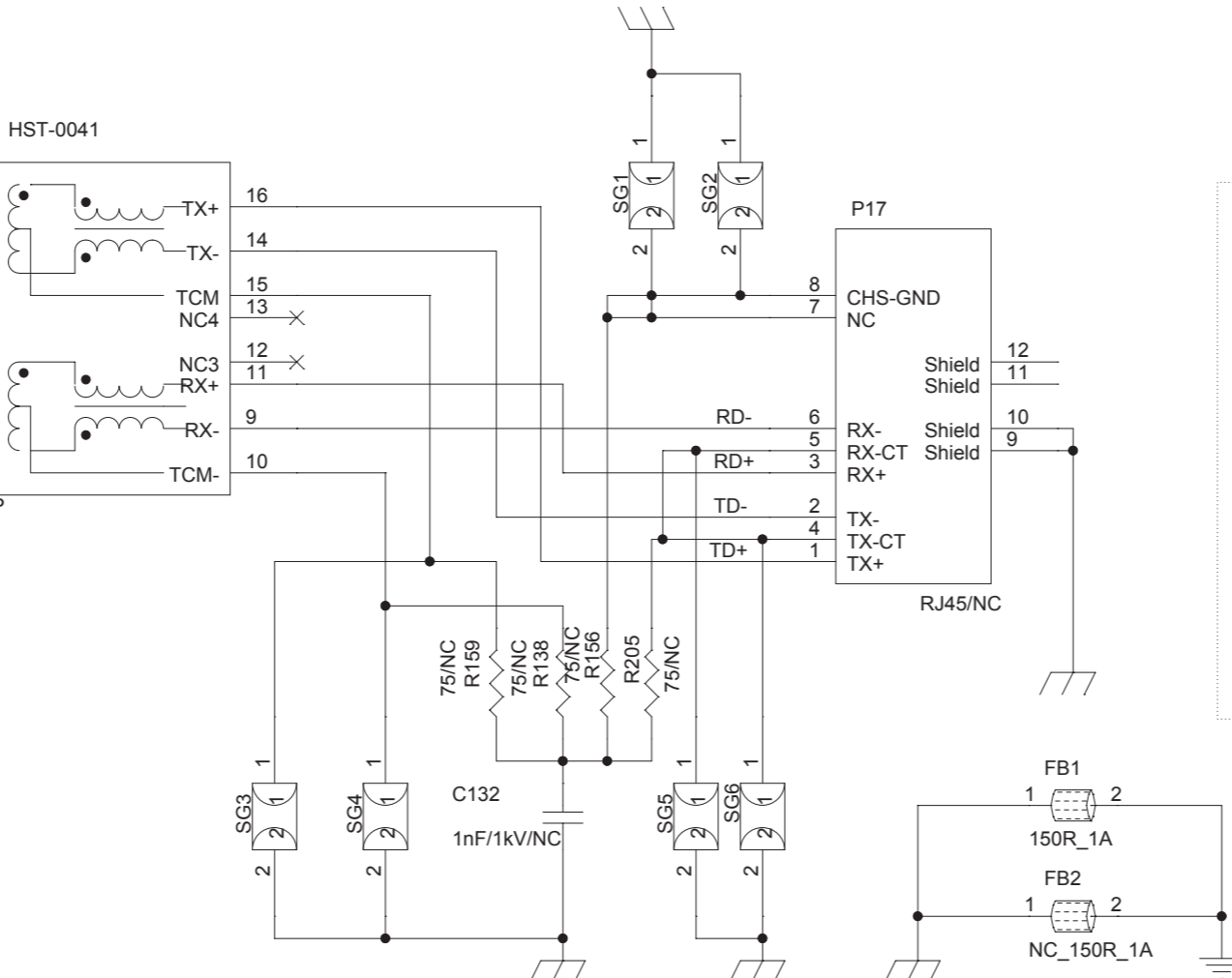
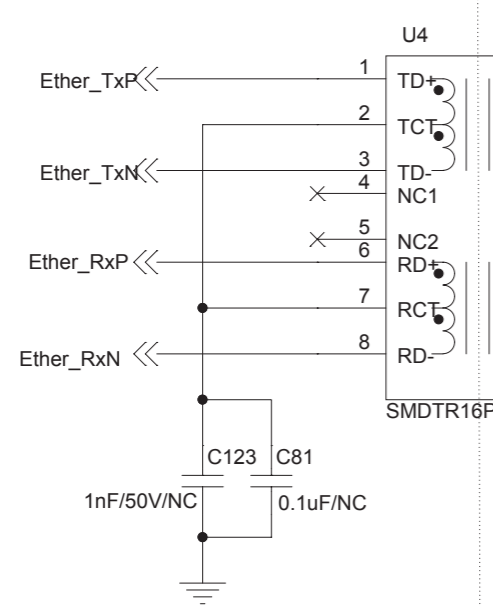
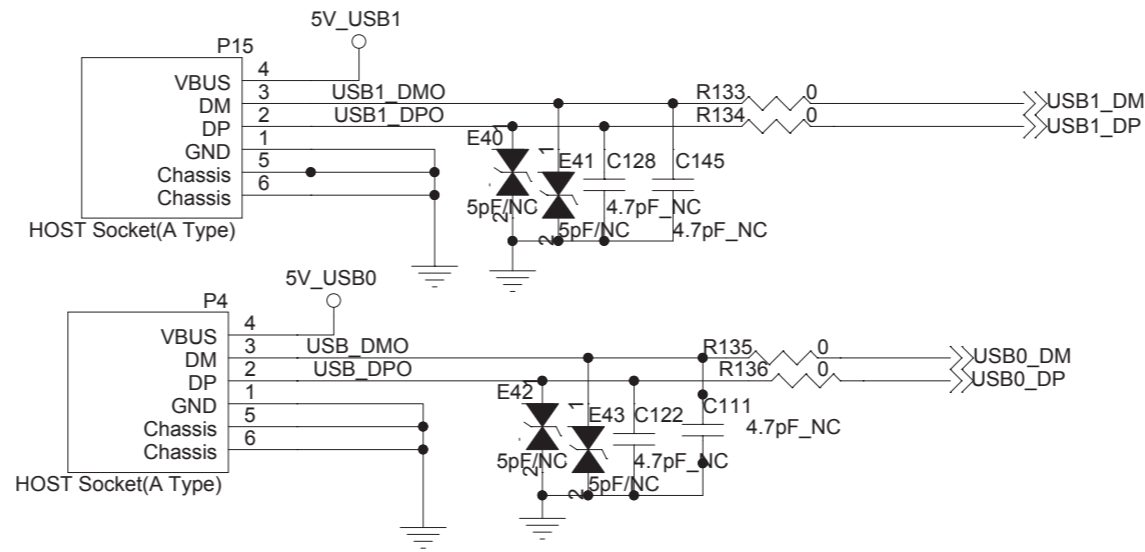
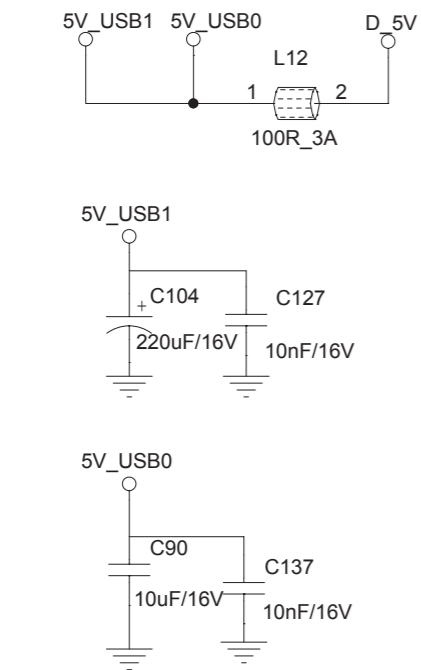

ESQUEMAS ELÉTRICOS

PCI Principal (Todos Modelos)

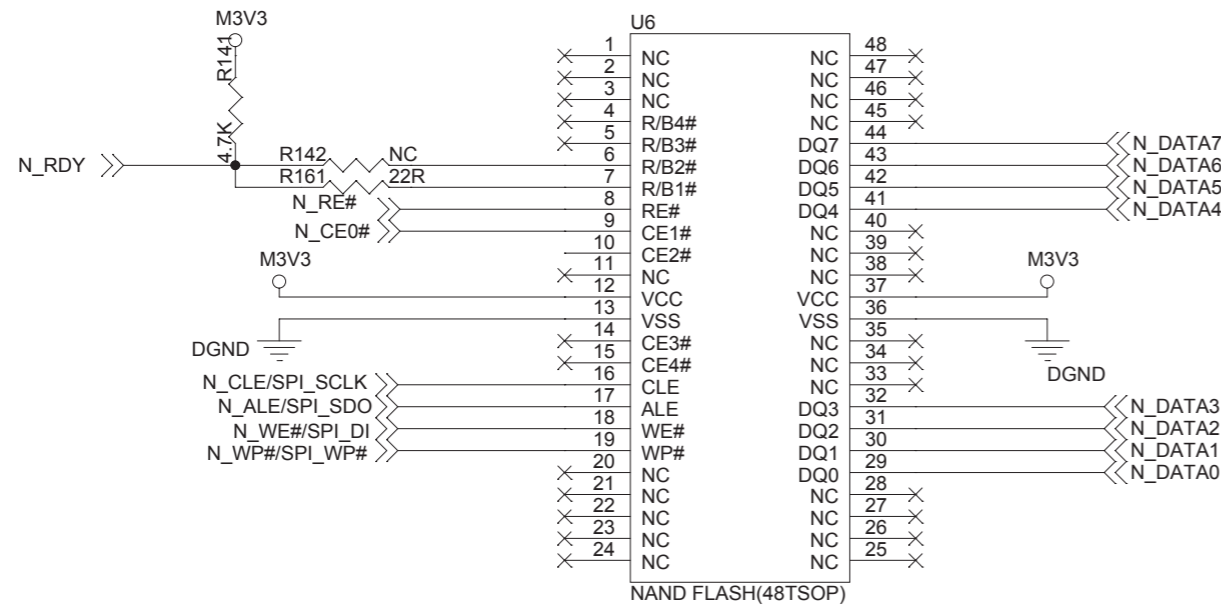

From Main Chip	
[3] N_WP#/SPI_WP#	N_WP#/SPI_WP#
[3] N_ALE/SPI_SDO	N_ALE/SPI_SDO
[3] N_CLE/SPI_SCLK	N_CLE/SPI_SCLK
[3] N_WE#/SPI_DI	N_WE#/SPI_DI
[3] SPI_CS#	SPI_CS#
[3] N_CE1#	N_CE1#
[3] N_CE0#	N_CE0#
[3] N_WE#/SPI_DI	N_WE#/SPI_DI
[3] N_RE#	N_RE#
[3] N_RDY	N_RDY
[3] N_DATA0	N_DATA0
[3] N_DATA1	N_DATA1
[3] N_DATA2	N_DATA2
[3] N_DATA3	N_DATA3
[3] N_DATA4	N_DATA4
[3] N_DATA5	N_DATA5
[3] N_DATA6	N_DATA6
[3] N_DATA7	N_DATA7
[3] EEPROM_WP	EEPROM_WP
[3] I2C_SCL	I2C_SCL
[3] I2C_SDA	I2C_SDA

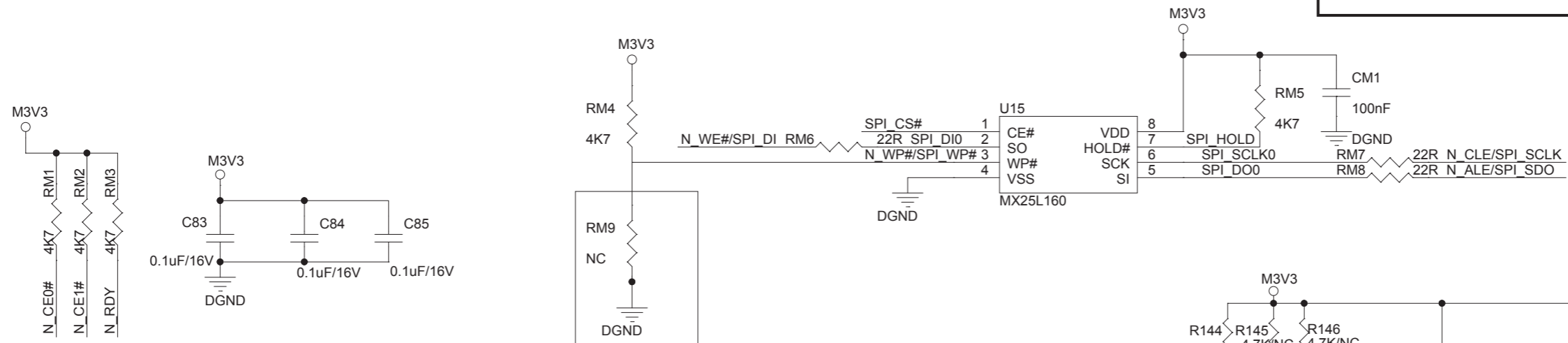

Caution: When Mass produce, RM4 chang to NC, RM9 chang to 4.7K

For Rtice Check

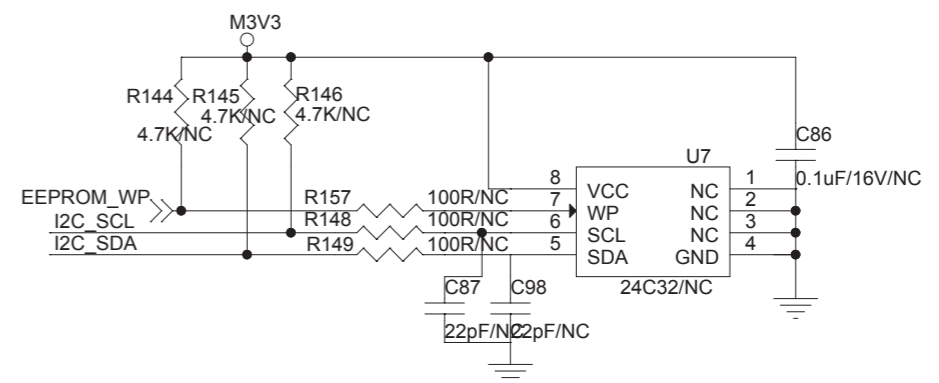
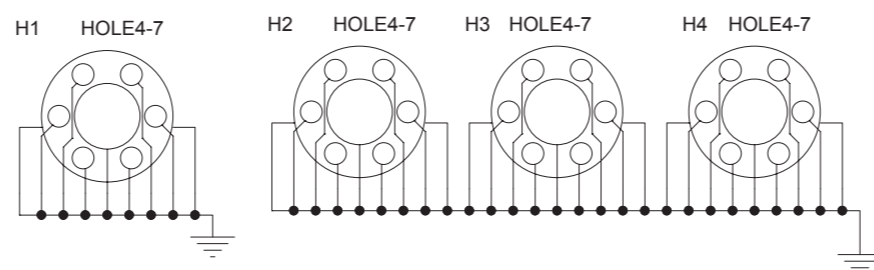

only 12V supply-----5V/3A MAIN POWER

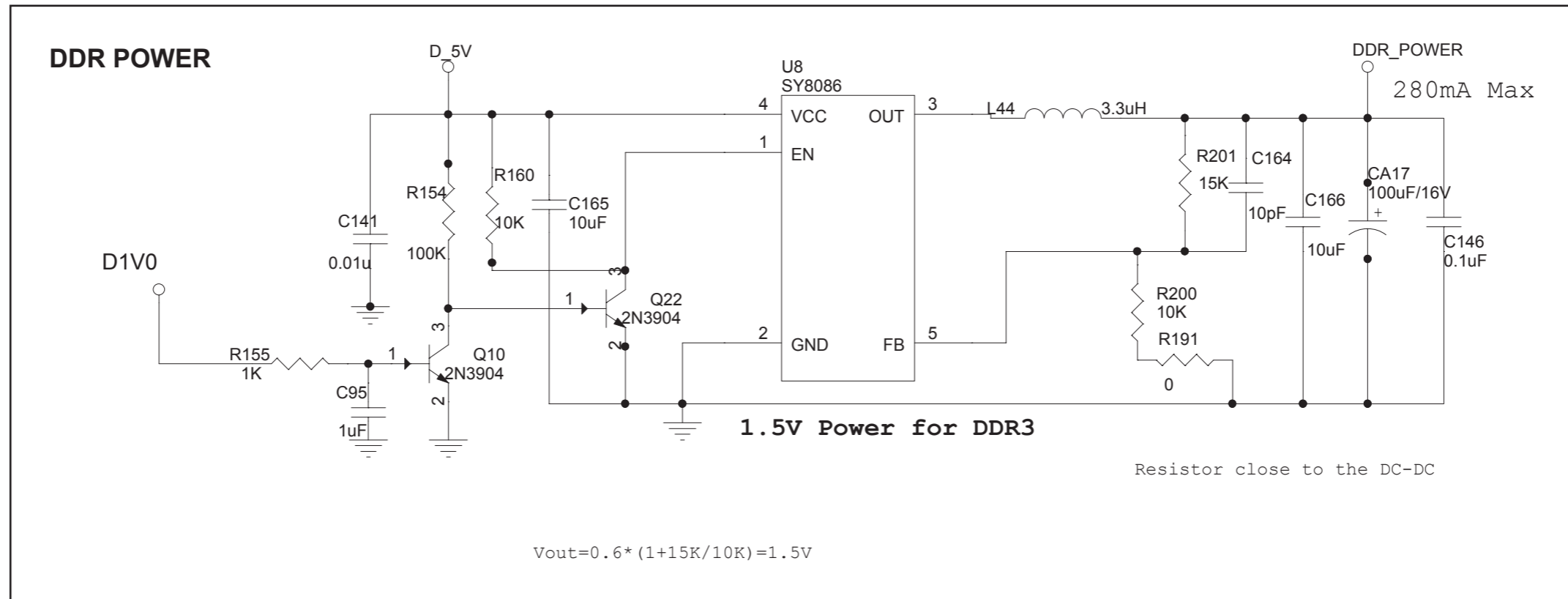
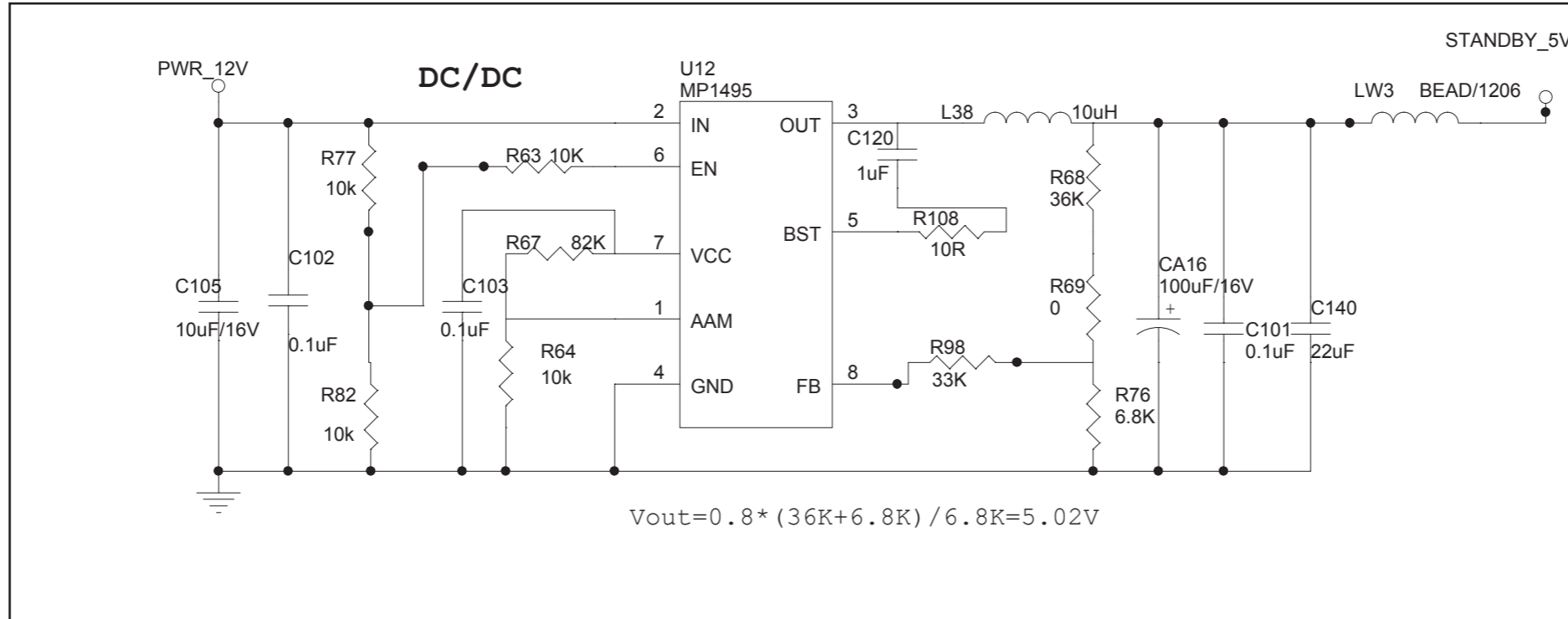

ESQUEMAS ELÉTRICOS

PCI Principal (Todos Modelos)

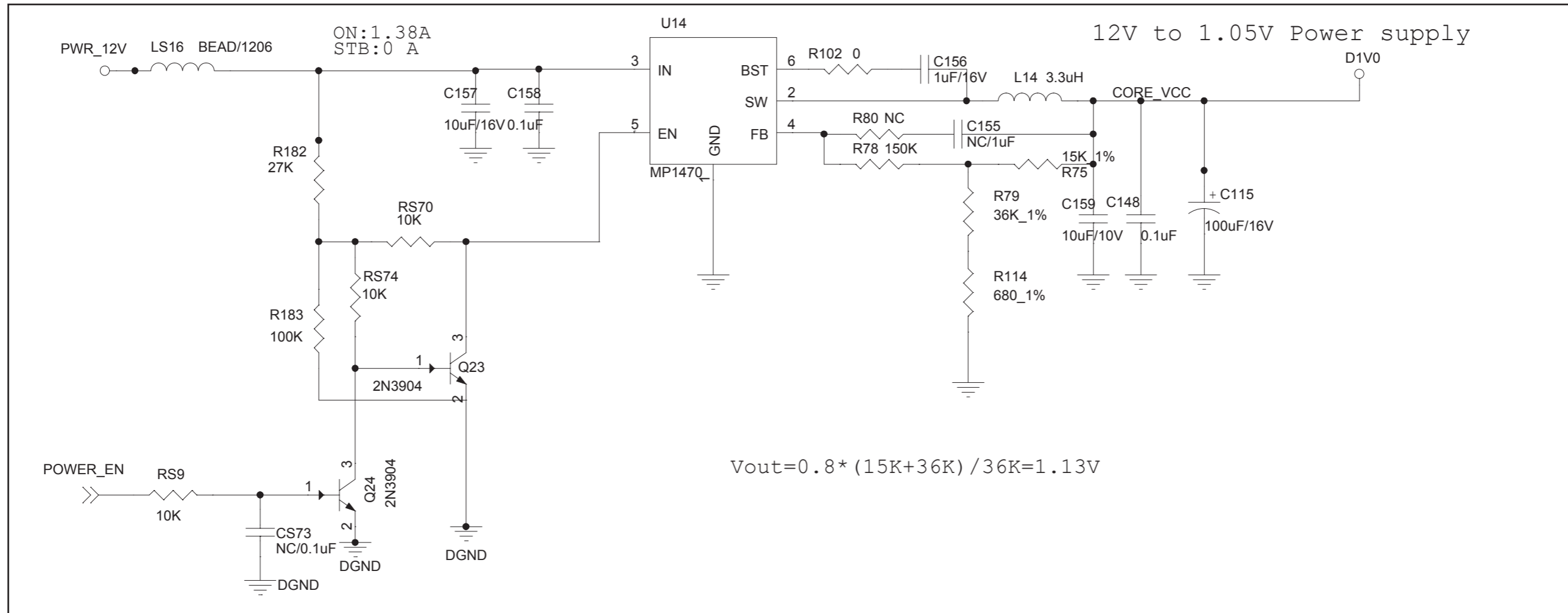
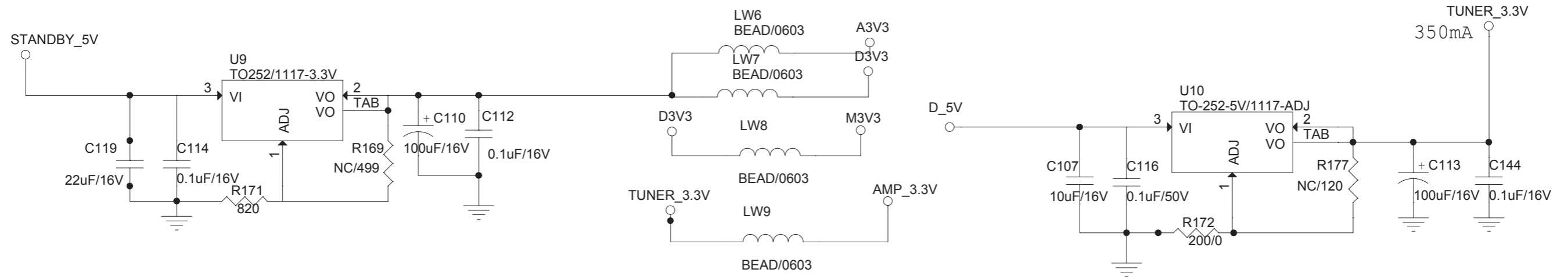

ESQUEMAS ELÉTRICOS

PCI Principal (Todos Modelos)

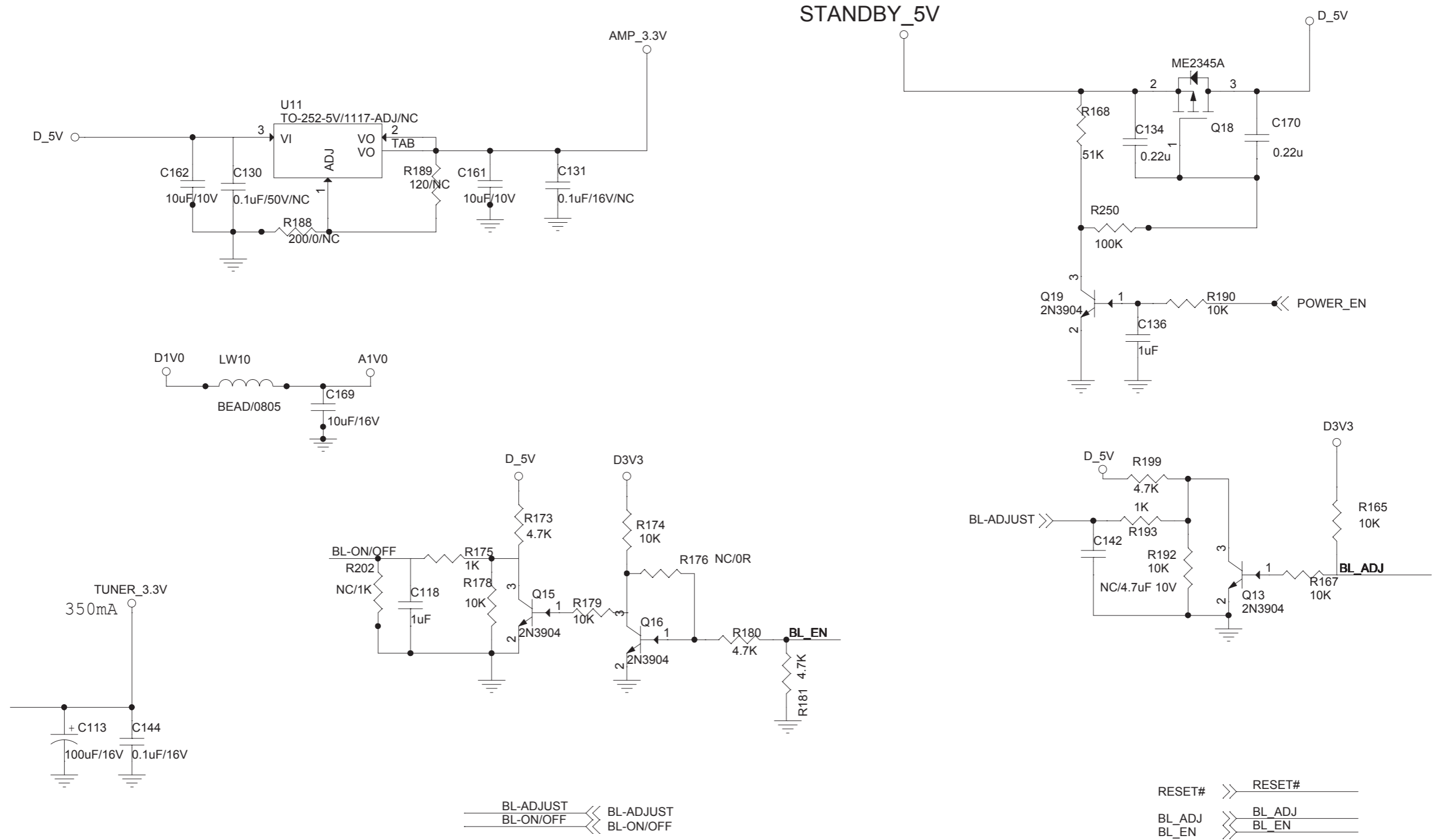

ESQUEMAS ELÉTRICOS

PCI Auxiliar (Todos Modelos)

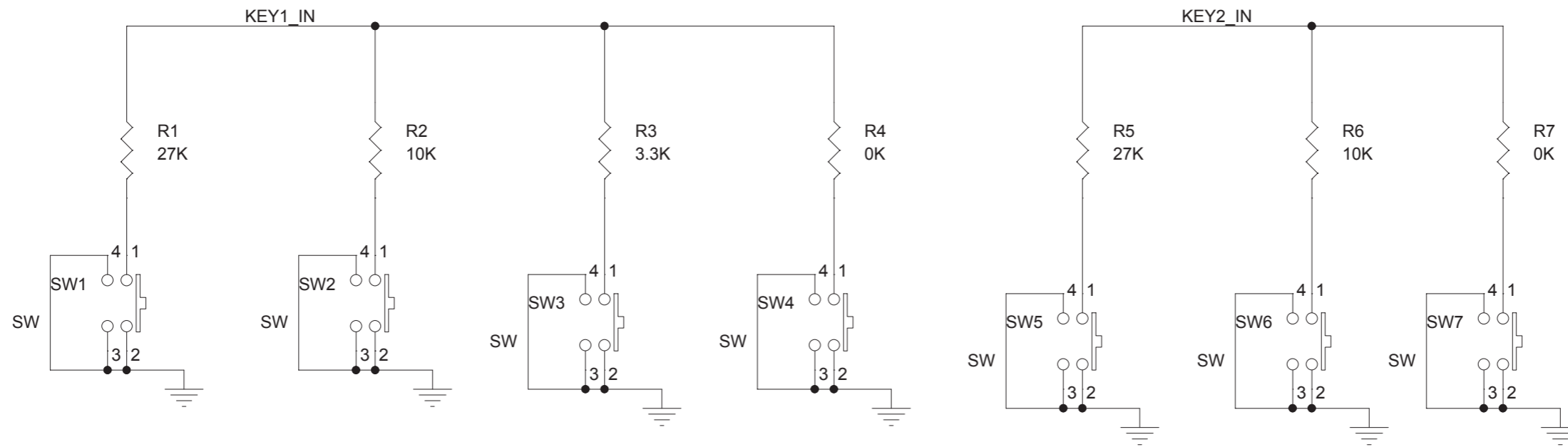
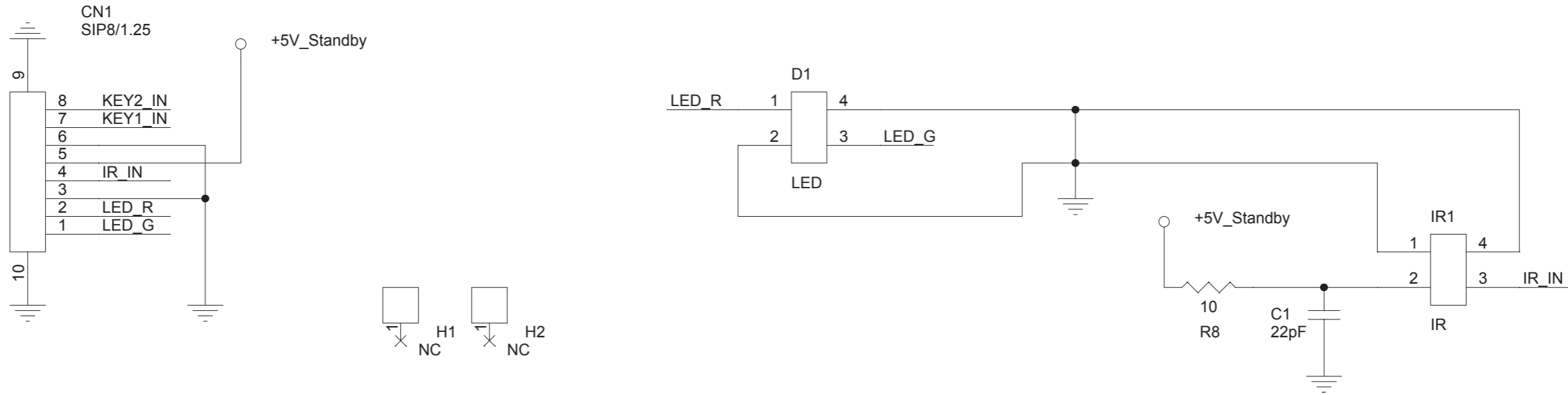

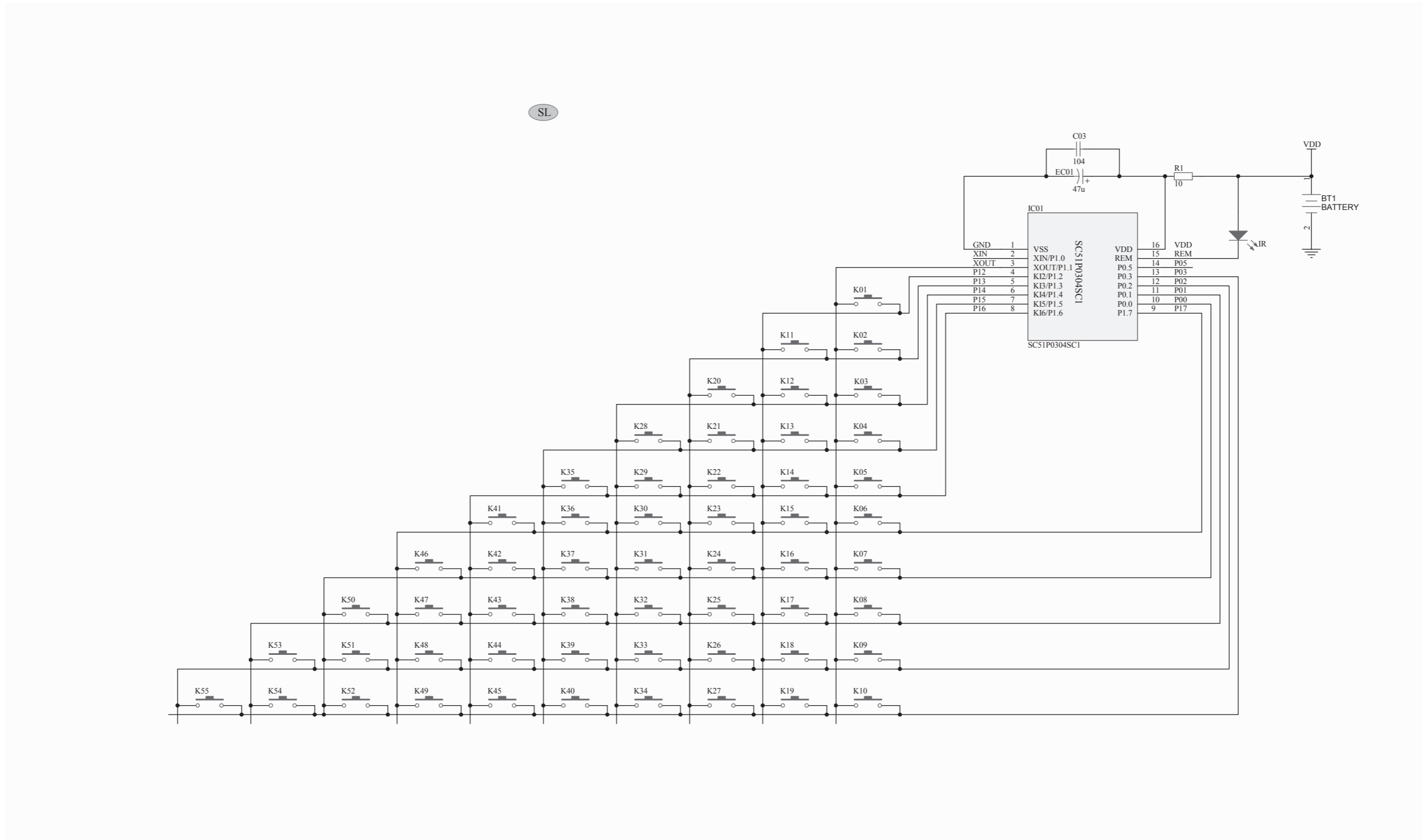

Avenida Arnaldo Rojek, nº 01,
Bairro: Alto da Jordanésia, Cidade: Cajamar, Estado: São Paulo, Cep: 07786-900

SEMP TOSHIBA