

# Airwell

# Service Manual

## DUO 38 DCI / DAKOTA

---

Indoor Units	Outdoor Units
WDI 7	DUO 38 DCI
WDI 9	
WDI 12	



---

**REFRIGERANT**

**R410A**

**HEAT PUMP**

SM DUO38I 1-A.2 GB

**JUNE – 2009**

**LIST OF EFFECTIVE PAGES**

**Note:** Changes in the pages are indicated by a “Revision#” in the footer of each effected page (when none indicates no changes in the relevant page). All pages in the following list represent effected/ non effected pages divided by chapters.

Dates of issue for original and changed pages are:

Original ..... 0 ..... January 2006

Total number of pages in this publication is 56 consisting of the following:

Page No.	Revision No. #		Page No.	Revision No. #		Page No.	Revision No. #
----------	----------------	--	----------	----------------	--	----------	----------------

Title ..... 1  
 A ..... 1  
 i ..... 1  
 1-1 ..... 1  
 2-1 - 2-4 ..... 2  
 3-1 - 3-1 ..... 1  
 4-1 - 4-2 ..... 1  
 5-1 - 5-9 ..... 1  
 6-1 - 6-2 ..... 1  
 7-1 ..... 2  
 8-1 ..... 1  
 9-1 - 9-2 ..... 1  
 10-1 ..... 1  
 11-1-11-18 ..... 1  
 12-1-12-6 ..... 1  
 13-1-13-2 ..... 2  
 Appendix -A ..... 1

- Zero in this column indicates an original page.

\*Due to constant improvements please note that the data on this service manual can be modified with out notice.

\*\*Photos are not contractual

**Table of Contents**

1.	INTRODUCTION .....	1-1
2.	PRODUCT DATA SHEET .....	2-1
3.	RATING CONDITIONS .....	3-1
4.	OUTLINE DIMENSIONS .....	4-1
5.	PERFORMANCE DATA .....	5-1
6.	PRESSURE CURVES .....	6-1
7.	ELECTRICAL DATA.....	7-1
8.	WIRING DIAGRAMS .....	8-1
9.	REFRIGERATION DIAGRAMS .....	9-1
10.	TUBING CONNECTIONS.....	10-1
11.	CONTROL SYSTEM .....	11-1
12.	TROUBLESHOOTING .....	12-1
13.	EXPLODED VIEWS AND SPARE PARTS LISTS.....	13-1
14.	APPENDIX A .....	14-1

# 1. INTRODUCTION

## 1.1 General

The new DUO 3.8 DCI Outdoor Unit is a high efficiency multi split inverter unit, supporting Indoor Units capacity range of - 2.2, 2.5 and 3.5 Kw.

## 1.2 Main Features

- DC Inverter
- R410A
- High COP (A class energy rating)
- Pre-Charged
- Base heater connection.
- Cooling operation at outdoor temperature down to -10°C.
- Heating operation at outdoor temperature down to -15°C.
- 10 LED's, shows both indoor and outdoor diagnostics.
- Variable Speed DC Inverter outdoor fan.
- M2L diagnostics software cable Port ( for PC).
- Low noise level

## 1.3 Tubing Connections

Flare type interconnecting tubing to be produced on site.

For further details please refer to APPENDIX A on this manual, and to the relevant indoor service Manual,

## 1.4 Inbox Documentation

Each indoor unit is supplied with its own installation and operation manuals.

## 1.5 Matching Table

### 1.5.1 R410A

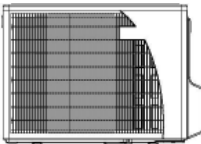
OUTDOOR UNITS		INDOOR UNITS			
					
	MODEL	REFRIGERANT	WDI 7 DCI	WDI 9 DCI	WDI 12 DCI
	DUO 38 DCI	R410A	√	√	√

**2. PRODUCT DATA SHEET**

**2.1 Outdoor Unit DUO 38 DCI / WDI Specifications.**

Model Indoor Unit		<b>WDI 7 9 12</b>		
Model Outdoor Unit		<b>DCI DUO 38 R410A</b>		
Installation Method of Pipe		Flared		
<b>Characteristics</b>	<b>Units</b>	<b>Cooling</b>	<b>Heating</b>	
Capacity <sup>(4)</sup>	Btu/hr	13300(4090-18750)	15350(4090-21140)	
	kW	3.90(1.50-5.50)	4.50(1.20-6.20)	
Power input <sup>(4)</sup>	kW	1.1(0.45-1.80)	1.24(0.45-1.80)	
EER (Cooling) or COP(Heating) <sup>(4)</sup>	W/W	3.55	3.61	
Energy efficiency class		A	A	
Power supply	V/Ph/Hz	220-240V/Single/50/60Hz		
Rated current	A	4.8	5.4	
Starting current	A	10.5		
Circuit breaker rating	A	15		
<b>OUTDOOR</b>	Refrigerant control	EEV		
	Compressor type,model	Single Rotary DC Inverter,Panasonic 5RS102XAB		
	Fan type & quantity	Propeller(direct) x 1		
	Fan speeds	H/L	RPM	920/500
	Air flow	H/L	m3/hr	2160
	Sound power level	H/L	dB(A)	62
	Sound pressure level <sup>(3)</sup>	H/L	dB(A)	52
	Dimensions	WxHxD	mm	795*290*610
	Weight		kg	38
	Package dimensions	WxHxD	mm	945*395*655
	Packaged weight		kg	40
	Units per pallet		Units	9 units per pallet
	Stacking height		units	3 levels
	Refrigerant type			R410A
	Refrigerant chargless distance		kg/m	1.2/7.5
	Additional charge per 1 meter		g/m	No need
Connections between units	Liquid line	In.(mm)	1/4"(6.35)	
	Suction line	In.(mm)	3/8"(9.53)	
	Max.tubing length	m.	Max.30	
	Max.height difference	m.	Max. 10	
Operation control type		Remote control		
Heating elements	kW			
Others				

(1)Airflow in ducted units;at nominal external static pressure.

(2)Sound power in ducted units is measured at air discharge.

(3)Sound pressure level measured at 1-meter distance from unit.

(4)Rating conditions in accordance to ISO 5151 and ISO 13253 (for ducted units).

## 2.2 Indoor Units Data

### 2.2.1 WDI 7 DCI Specifications

Model Indoor Unit / Type				WDI 7 DCI / Wall Mounted		
Installation Method				FLARE		
Power Supply		V/Ph/Hz		220-240 / 1/ 50/60		
<b>INDOOR</b>	Fan Type & Quantity			Crossflow *1		
	Airflow <sup>(2)</sup> Cooling / Heating	H/M/L	m <sup>3</sup> /hr	400	350	300
	Sound Power Level <sup>(3)</sup> Cooling / Heating	L - H	dB (A)	49/46/43		
	Sound Pressure Level <sup>(4)</sup> Cooling / Heating	L - H	dB (A)	36/33/30		
	Condensate Drain Tube I.D.		mm	16		
	Dimensions	W/H/D	mm	680	250	185
	Weight		kg	7		
	Package Dimensions	W/H/D	mm	740	320	265
	Stacking Height		Units	9 LEVELS		
	Heating Elements		kW	N/A		
Moisture Removal		L/hr	1			

### 2.2.2 WDI 9 DCI Specifications

Model Indoor Unit / Type				WDI 9 DCI / Wall Mounted		
Installation Method				FLARE		
Power Supply		V/Ph/Hz		220-240 / 1/ 50/60		
<b>INDOOR</b>	Fan Type & Quantity			Crossflow *1		
	Airflow <sup>(2)</sup> Cooling / Heating	H/M/L	m <sup>3</sup> /hr	420	350	270
	Sound Power Level <sup>(3)</sup> Cooling / Heating	L - H	dB (A)	52/48/45		
	Sound Pressure Level <sup>(4)</sup> Cooling / Heating	L - H	dB (A)	39/35/32		
	Condensate Drain Tube I.D.		mm	16		
	Dimensions	W/H/D	mm	680	250	185
	Weight		kg	7		
	Package Dimensions	W/H/D	mm	740	320	260
	Stacking Height		Units	9 LEVELS		
	Heating Elements		kW	N/A		
Moisture Removal		L/hr	1.0			

- (1) Rating conditions in accordance with ISO 5151 and ISO 13253 (for ducted units) and EN14511.
- (2) Airflow in ducted units; at nominal external static pressure.
- (3) Sound power in ducted units is measured at air discharge.
- (4) Sound pressure level measured at 1 meter distance from unit.

**2.2.3 WDI 12 DCI Specifications**

Model Indoor Unit / Type				<b>WDI 12 DCI / Wall Mounted</b>		
Installation Method				FLARE		
Power Supply		V/Ph/Hz		220-240 / 1/ 50/60		
<b>INDOOR</b>	Fan Type & Quantity			Crossflow *1		
	Airflow <sup>(2)</sup> Cooling / Heating	H/M/L	m <sup>3</sup> /hr	550	450	350
	Sound Power Level <sup>(3)</sup> Cooling / Heating	L - H	dB (A)	56/46/42		
	Sound Pressure Level <sup>(4)</sup> Cooling / Heating	L - H	dB (A)	39/33/29		
	Condensate Drain Tube I.D.		mm	16		
	Dimensions	W/H/D	mm	840	250	185
	Weight		kg	8.0		
	Package Dimensions	W/H/D	mm	930	320	265
	Stacking Height		Units	9 LEVELS		
	Heating Elements		kW	N/A		
Moisture Removal		L/hr	1.5			

- (1) Rating conditions in accordance with ISO 5151 and ISO 13253 (for ducted units) and EN14511.
- (2) Airflow in ducted units; at nominal external static pressure.
- (3) Sound power in ducted units is measured at air discharge.
- (4) Sound pressure level measured at 1 meter distance from unit.

**2.2.4 Indoor Units Combinations**

Indoor Units Combinations	Cooling				Heating			
	Room A	Room B	Total Capacity	Power Input	Room A	Room B	Total Capacity	Power Input
	[W]	[W]	[W]	[W]	[W]	[W]	[W]	[W]
7	2200	-	2200 (1500 - 2600)	675 (450 - 850)	2500	-	2500 (1200 - 3100)	750 (450 - 1000)
9	2500	-	2500 (1500 - 3000)	750 (450 - 980)	2800	-	2800 (1200 - 3500)	910 (450 - 1220)
12	3500	-	3500 (1500 - 4100)	1030 (450 - 1250)	3600	-	3600 (1200 - 4100)	1030 (450 - 1150)
7+7	1850	1850	3700 (1500 - 4700)	1000 (450-1800)	2150	2150	4300 (1200 - 5200)	1200 (450 - 1800)
7+9	1850	1950	3800 (1500 - 4800)	1050 (450 - 1800)	2150	2250	4400 (1200 - 5300)	1240 (450 - 1800)
7+12	1850	3050	4900 (1500 - 5200)	1350 (450 - 1800)	2150	3250	5400 (1200 - 5900)	1520 (450 - 1800)
9+9	1950	1950	3900 (1500 - 5500)	1100 (450 - 1800)	2250	2250	4500 (1200 - 6200)	1280 (450 - 1800)
9+12	1950	3050	5000 (1500 - 5500)	1400 (450 - 1800)	2250	3250	5500 (1200 - 6200)	1560 (450 - 1800)

### 3. RATING CONDITIONS

Standard conditions in accordance with ISO 5151, ISO 13253 (for ducted units) and EN 14511.

**Cooling:**

Indoor: 27°C DB 19°C WB

Outdoor: 35°C DB

**Heating:**

Indoor: 20°C DB

Outdoor: 7°C DB 6°C WB

#### 3.1 Operating Limits

		Indoor	Outdoor
<b>Cooling</b>	Upper limit	32°C DB 23°C WB	46°C DB
	Lower limit	21°C DB 15°C WB	-10°C DB
<b>Heating</b>	Upper limit	27°C DB	24°C DB 18°C WB
	Lower limit	10°C DB	-15°C DB -16°C WB
<b>Voltage</b>	1PH	198 – 264 V	
	3PH	N/A	



## 4. OUTLINE DIMENSIONS

### 4.1 Indoor Unit: WDI 7, WDI 9 DCI

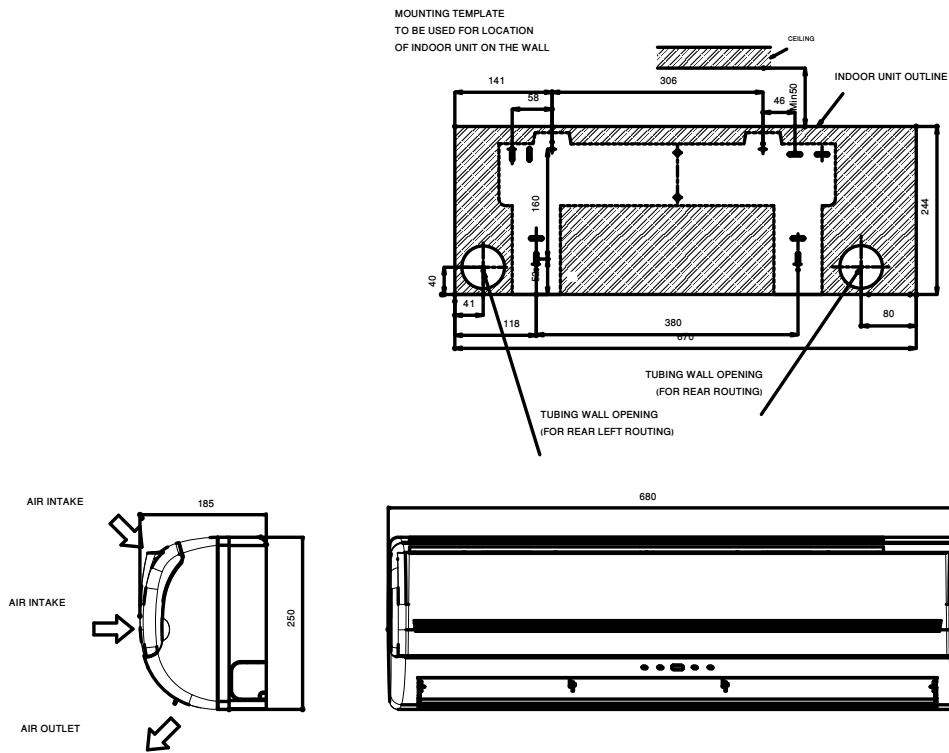

### 4.2 Indoor Unit: WDI 12 DCI

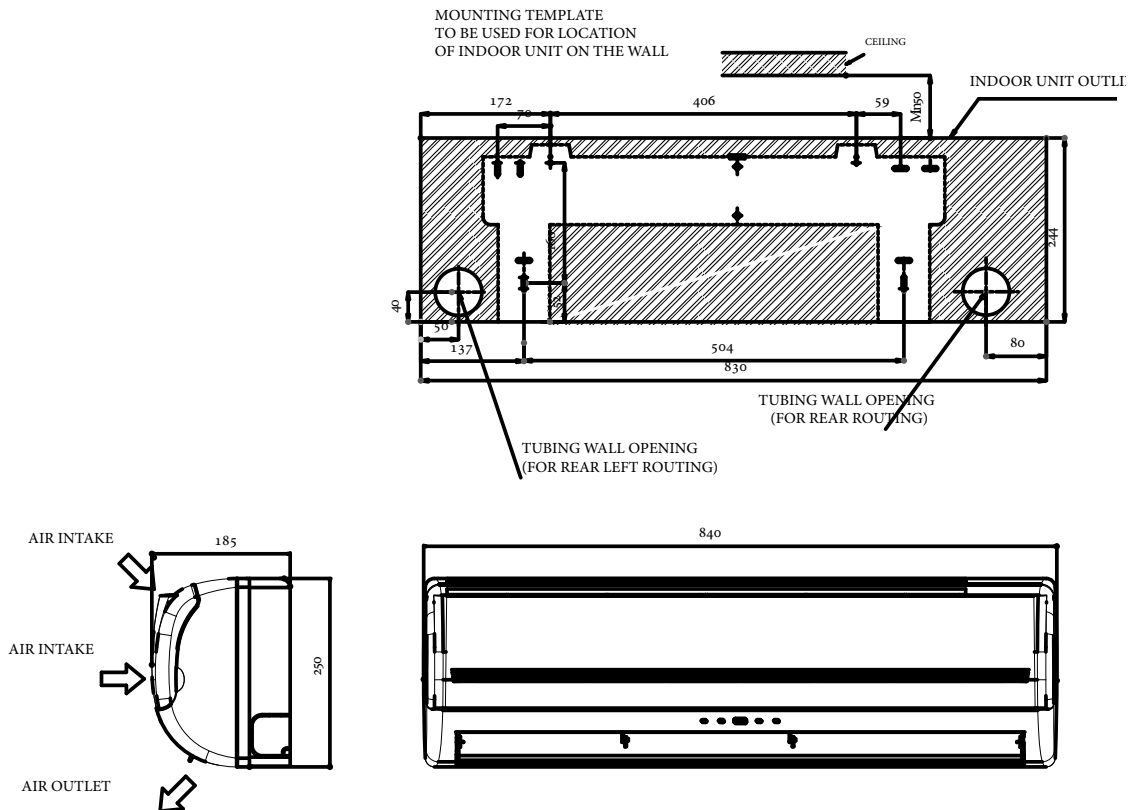

**4.3 Outdoor Unit: DUO 38 DCI**

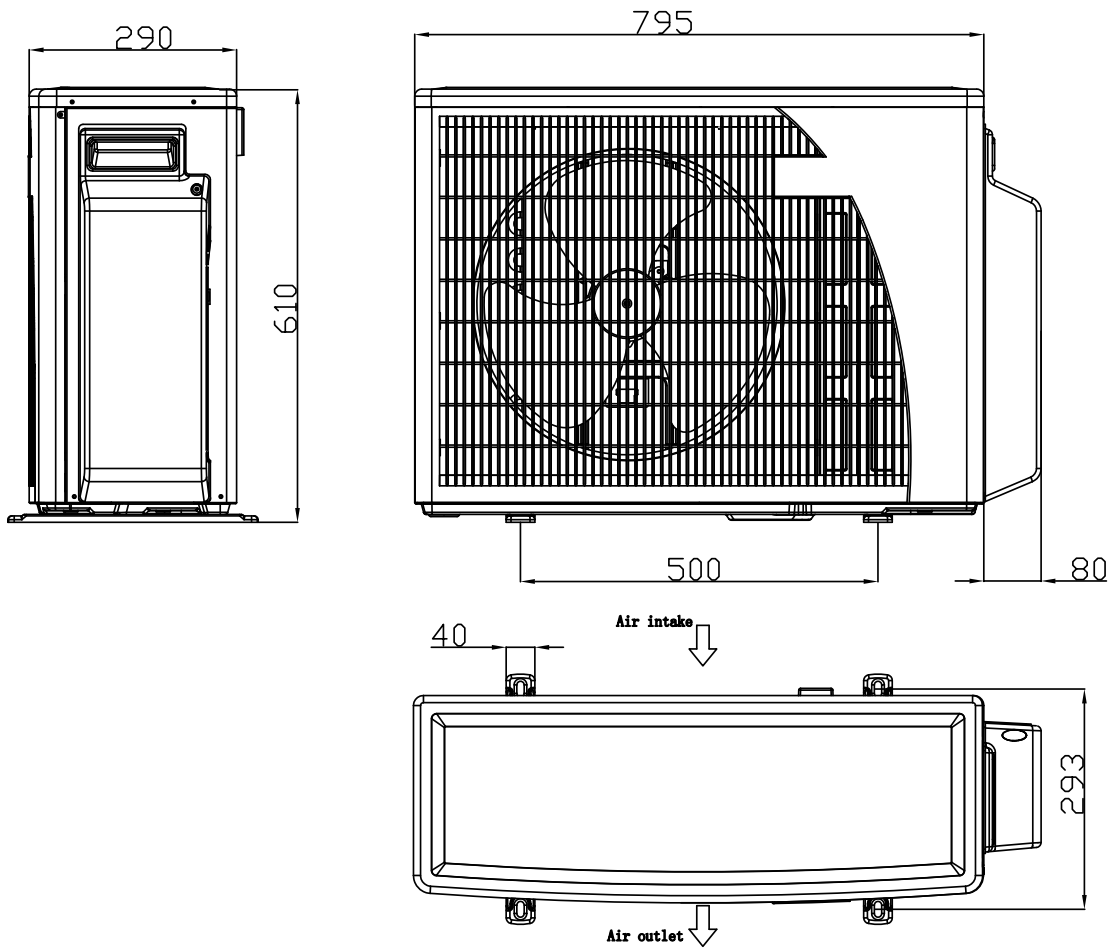

## 5. PERFORMANCE DATA

### 5.1 WDI 7-7 DCI

#### 5.1.1 Cooling Capacity (kW) - Run Mode (Unit A or B)

230[V] : Indoor Fan at High Speed.

		ID COIL ENTERING AIR DB/WB TEMPERATURE [0C]				
OD COIL ENTERING AIR DB TEMPERATURE [0C]	DATA	22/15	24/17	27/19	29/21	32/23
-10 - 20 (protection range)	TC	80 - 110 % of nominal				
	SC	80 - 105 % of nominal				
	PI	25 - 50 % of nominal				
25	TC	1.98	2.10	2.22	2.33	2.45
	SC	1.53	1.57	1.61	1.64	1.68
	PI	0.39	0.40	0.41	0.42	0.43
30	TC	1.80	1.92	2.03	2.15	2.26
	SC	1.46	1.49	1.53	1.56	1.60
	PI	0.44	0.45	0.45	0.46	0.47
35	TC	1.62	1.73	<b>1.85</b>	1.97	2.08
	SC	1.38	1.41	<b>1.45</b>	1.49	1.52
	PI	0.48	0.49	<b>0.50</b>	0.51	0.52
40	TC	80%-92% of nominal				
	SC	80%-92% of nominal				
	PI	80%-100% of nominal				
46	TC	70%-85% of nominal				
	SC	70%-85% of nominal				
	PI	90%-100% of nominal				

#### LEGEND

- TC – Total Cooling Capacity, kW
- SC – Sensible Capacity, kW
- PI – Power Input, kW
- WB – Wet Bulb Temp., (°C)
- DB – Dry Bulb Temp., (°C)
- ID – Indoor
- OD – Outdoor

#### 5.1.2 Capacity Correction Factors

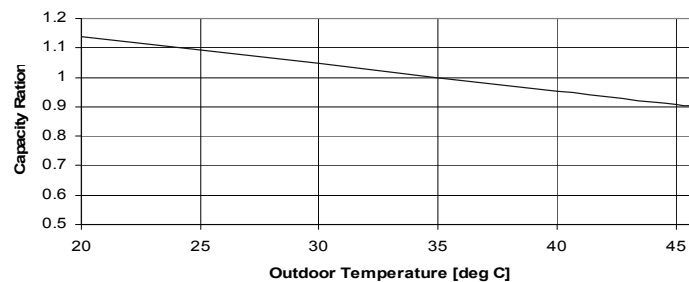

**5.1.3 Heating Capacity (kW) - Run Mode(Unit A or B)**

**230[V] : Indoor Fan at High Speed.**

OD COIL ENTERING AIR DB/WB TEMPERATURE [C°]	DATA	ID COIL ENTERING AIR DB TEMPERATURE [C°]		
		15	20	25
-15/-16	TC	1.15	1.07	1.00
	PI	0.38	0.44	0.49
-10/-12	TC	1.37	1.30	1.23
	PI	0.44	0.50	0.55
-7/-8	TC	1.54	1.47	0.55
	PI	0.49	0.54	0.60
-1/-2	TC	1.63	1.56	1.49
	PI	0.51	0.56	0.62
2/1	TC	1.68	1.61	1.54
	PI	0.52	0.58	0.63
7/6	TC	2.22	<b>2.15</b>	2.08
	PI	0.54	<b>0.60</b>	0.66
10/9	TC	2.31	2.24	2.17
	PI	0.57	0.63	0.68
15/12	TC	2.40	2.33	2.26
	PI	0.60	0.65	0.71
15-24 (Protection Range)	TC	85 - 105 % of nominal		
	PI	80 - 120 % of nominal		

**LEGEND**

- TC – Total Cooling Capacity, kW
- PI – Power Input, kW
- WB – Wet Bulb Temp., (°C)
- DB – Dry Bulb Temp., (°C)
- ID – Indoor
- OD – Outdoor

**5.1.4 Capacity Correction Factors**

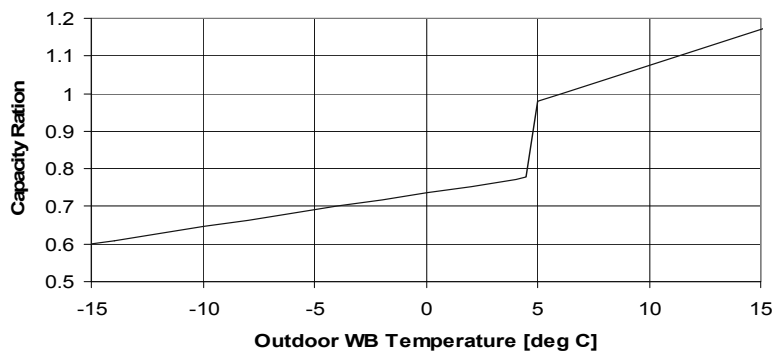

5.2 WDI 9-9 DCI

5.2.1 Cooling Capacity (kW) - Run Mode (Unit A or B)

230[V] : Indoor Fan at High Speed.

OD COIL ENTERING AIR DB TEMPERATURE [°C]		ID COIL ENTERING AIR DB/WB TEMPERATURE [°C]				
		DATA	22/15	24/17	27/19	29/21
-10 - 20 (protection range)	TC	80 - 110 % of nominal				
	SC	80 - 105 % of nominal				
	PI	25 - 50 % of nominal				
25	TC	2.09	2.21	2.34	2.46	2.58
	SC	1.64	1.68	1.72	1.76	1.80
	PI	0.43	0.44	0.45	0.46	0.47
30	TC	1.90	2.02	2.14	2.27	2.39
	SC	1.56	1.59	1.63	1.67	1.71
	PI	0.48	0.49	0.50	0.51	0.52
35	TC	1.71	1.83	<b>1.95</b>	2.07	2.19
	SC	1.47	1.51	<b>1.55</b>	1.59	1.63
	PI	0.53	0.54	<b>0.55</b>	0.56	0.57
40 (protection range)	TC	80%-92% of nominal				
	SC	80%-92% of nominal				
	PI	80%-100% of nominal				
46 (protection range)	TC	70%-85% of nominal				
	SC	70%-85% of nominal				
	PI	90%-100% of nominal				

**LEGEND**

- TC – Total Cooling Capacity, kW
- SC – Sensible Capacity, kW
- PI – Power Input, kW
- WB – Wet Bulb Temp., (°C)
- DB – Dry Bulb Temp., (°C)
- ID – Indoor
- OD – Outdoor

5.2.2 Capacity Correction Factors

Cooling Capacity Ratio Vs. Outdoor Temperature

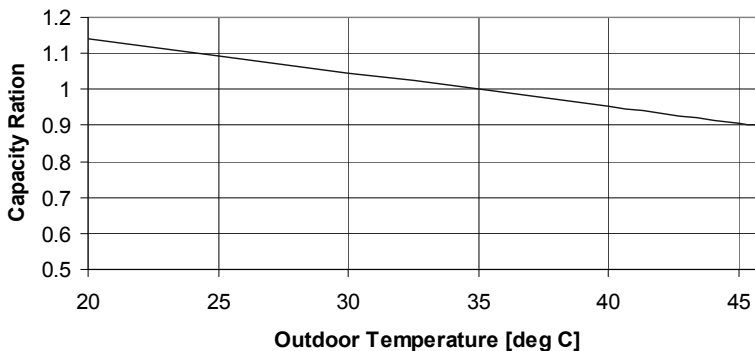

**5.2.3 Heating Capacity (kW) - Run Mode(Unit A or B)**

230[V] : Indoor Fan at High Speed.

OD COIL ENTERING AIR DB/WB TEMPERATURE [°C]	DATA	ID COIL ENTERING AIR DB TEMPERATURE [°C]		
		15	20	25
-15/-16	TC	1.20	1.12	1.05
	PI	0.41	0.47	0.53
-10/-12	TC	1.44	1.36	1.29
	PI	0.47	0.53	0.59
-7/-8	TC	1.61	1.54	1.47
	PI	0.52	0.58	0.64
-1/-2	TC	1.70	1.63	1.55
	PI	0.54	0.60	0.66
2/1	TC	1.76	1.69	1.61
	PI	0.56	0.62	0.68
7/6	TC	2.32	2.25	2.18
	PI	0.58	0.64	0.70
10/9	TC	2.42	2.34	2.27
	PI	0.61	0.67	0.73
15/12	TC	2.51	2.43	2.36
	PI	0.64	0.69	0.75
15-24 (Protection Range)	TC	85 - 105 % of nominal		
	PI	80 - 120 % of nominal		

**LEGEND**

- TC – Total Cooling Capacity, kW
- PI – Power Input, kW
- WB – Wet Bulb Temp., (°C)
- DB – Dry Bulb Temp., (°C)
- ID – Indoor
- OD – Outdoor

**1.3.4 Capacity Correction Factors**

Heating Capacity Ratio Vs. Outdoor Temperature

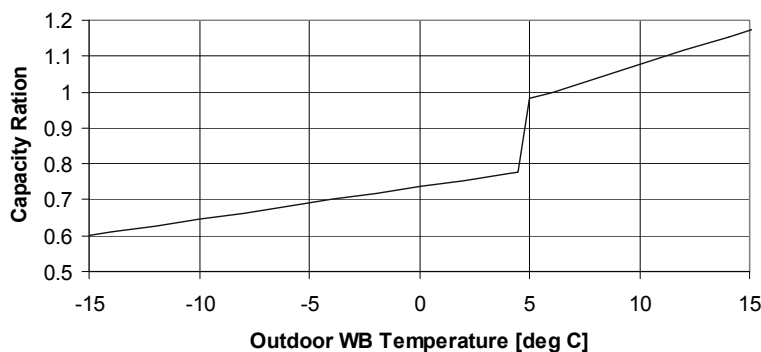

5.3 WDI 9-12

5.3.1 Cooling Capacity (kW) - Run Mode(Unit A or B)

230[V] : Indoor Fan at High Speed.

OD COIL ENTERING AIR DB TEMPERATURE [°C]		DATA	ID COIL ENTERING AIR DB/WB TEMPERATURE [°C]				
			22/15	24/17	27/19	29/21	32/23
-10 - 20 (protection range)	TC	80 - 110 % of nominal					
	SC	80 - 105 % of nominal					
	PI	25 - 50 % of nominal					
25	TC	3.27	3.46	3.65	3.84	4.04	
	SC	2.22	2.27	2.33	2.38	2.43	
	PI	0.67	0.68	0.70	0.71	0.72	
30	TC	2.97	3.16	3.35	3.54	3.73	
	SC	2.11	2.16	2.21	2.27	2.32	
	PI	0.75	0.76	0.77	0.79	0.80	
35	TC	2.67	2.86	<b>3.05</b>	3.24	3.43	
	SC	1.99	2.05	<b>2.10</b>	2.15	2.21	
	PI	0.82	0.84	<b>0.85</b>	0.86	0.88	
40	TC	80%-92% of nominal					
	SC	80%-92% of nominal					
	PI	80%-100% of nominal					
46	TC	70%-85% of nominal					
	SC	70%-85% of nominal					
	PI	90%-100% of nominal					

**LEGEND**

- TC – Total Cooling Capacity, kW
- SC – Sensible Capacity, kW
- PI – Power Input, kW
- WB – Wet Bulb Temp., (°C)
- DB – Dry Bulb Temp., (°C)
- ID – Indoor
- OD – Outdoor

5.3.2 Capacity Correction Factors

Cooling Capacity Ratio Vs. Outdoor Temperature

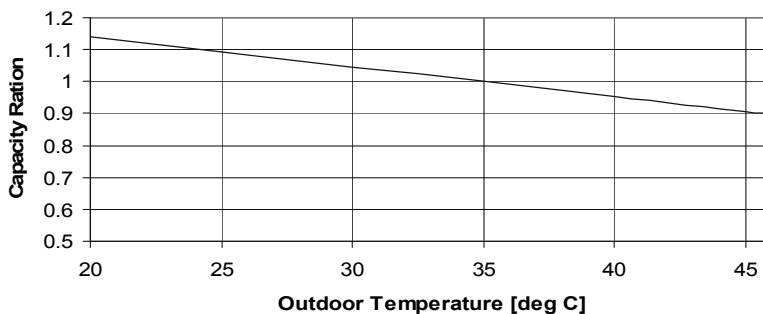

**5.3.3 Heating Capacity (kW) - Run Mode(Unit A or B)**  
**230[V] : Indoor Fan at High Speed.**

OD COIL ENTERING AIR DB/WB TEMPERATURE [°C]	DATA	ID COIL ENTERING AIR DB TEMPERATURE [°C]		
		15	20	25
-15/-16	TC	1.73	1.62	1.52
	PI	0.59	0.67	0.76
-10/-12	TC	2.07	1.97	1.86
	PI	0.68	0.76	0.85
-7/-8	TC	2.33	2.22	2.12
	PI	0.75	0.83	0.91
-1/-2	TC	2.46	2.35	2.25
	PI	0.78	0.86	0.95
2/1	TC	2.55	2.44	2.33
	PI	0.80	0.89	0.97
7/6	TC	3.36	3.25	3.14
	PI	0.84	0.92	1.00
10/9	TC	3.49	3.38	3.28
	PI	0.87	0.96	1.04
15/12	TC	3.62	3.52	3.41
	PI	0.91	1.00	1.08
15-24 (Protection Range)	TC	85 - 105 % of nominal		
	PI	80 - 120 % of nominal		

**LEGEND**

- TC – Total Cooling Capacity, kW
- PI – Power Input, kW
- WB – Wet Bulb Temp., (°C)
- DB – Dry Bulb Temp., (°C)
- ID – Indoor
- OD – Outdoor

**5.3.4 Capacity Correction Factors**

Cooling Capacity Ratio Vs. Outdoor Temperature

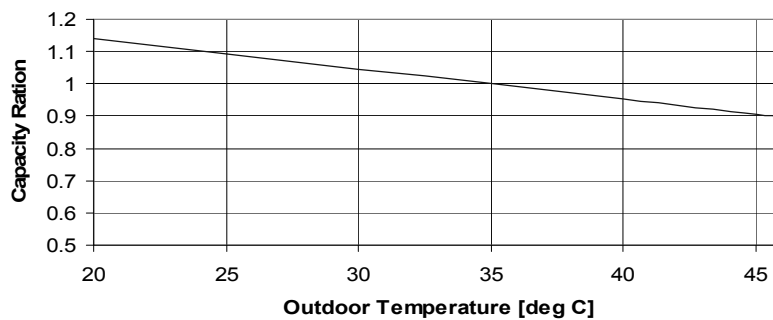



**5.4 Capacity Correction Factor Due to Tubing Length (OneWay)**

**5.4.1 WDI 7 / 9 / 12 DCI**

**5.4.2 Cooling**

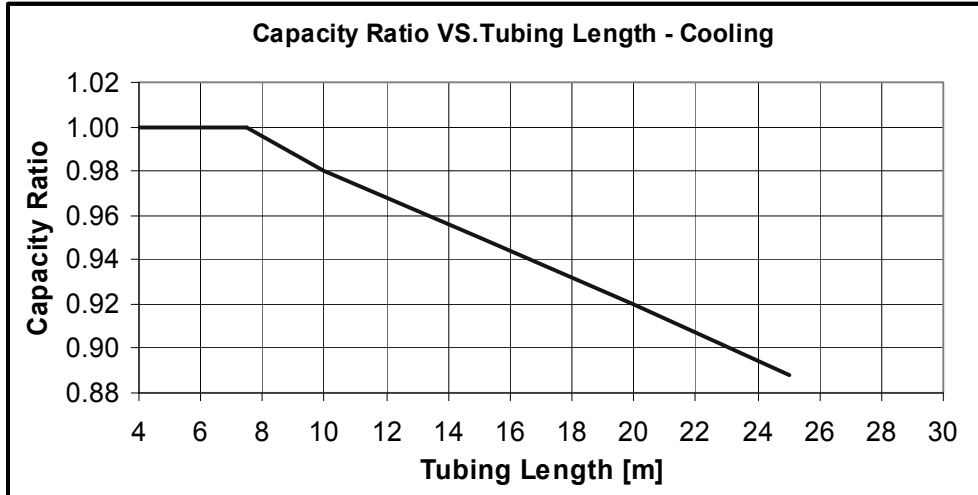

**5.4.3 Heating**

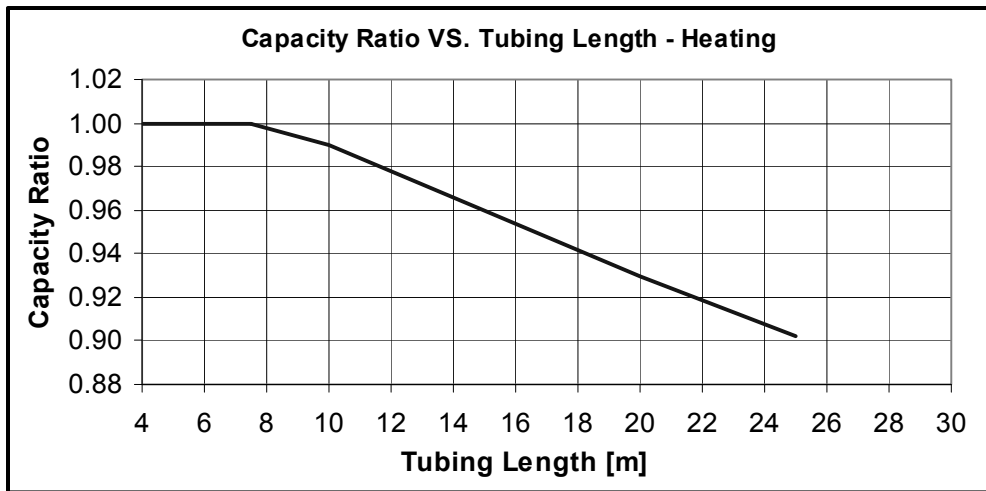

**6. PRESSURE CURVES**

**6.1 Model: WDI 7-7, WDI 9-9 DUO 38 DCI**

**6.1.1 Cooling – Test Mode**

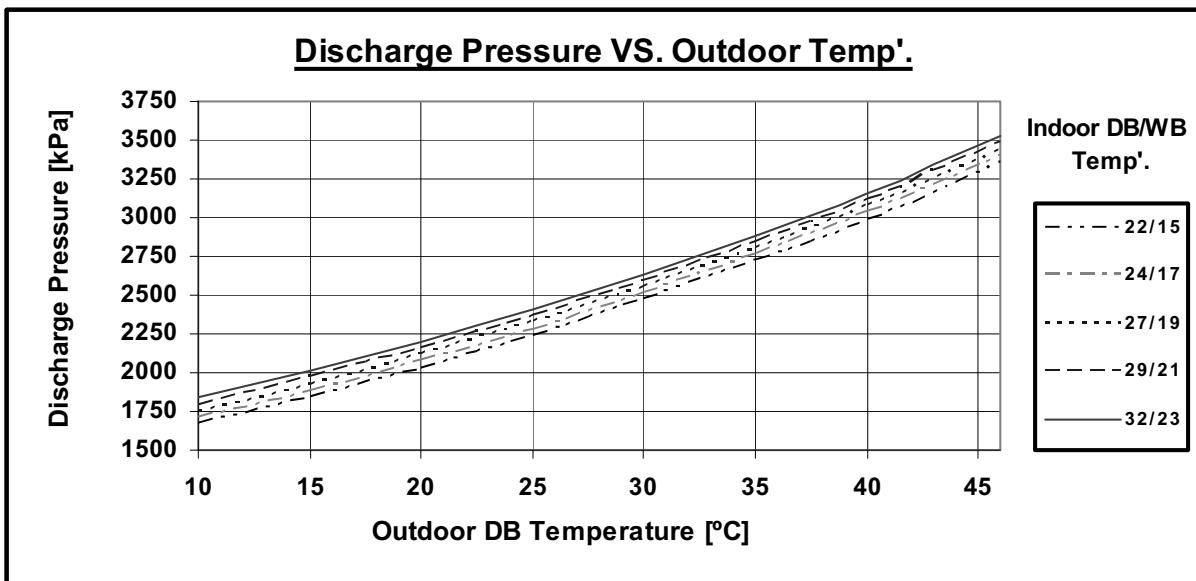
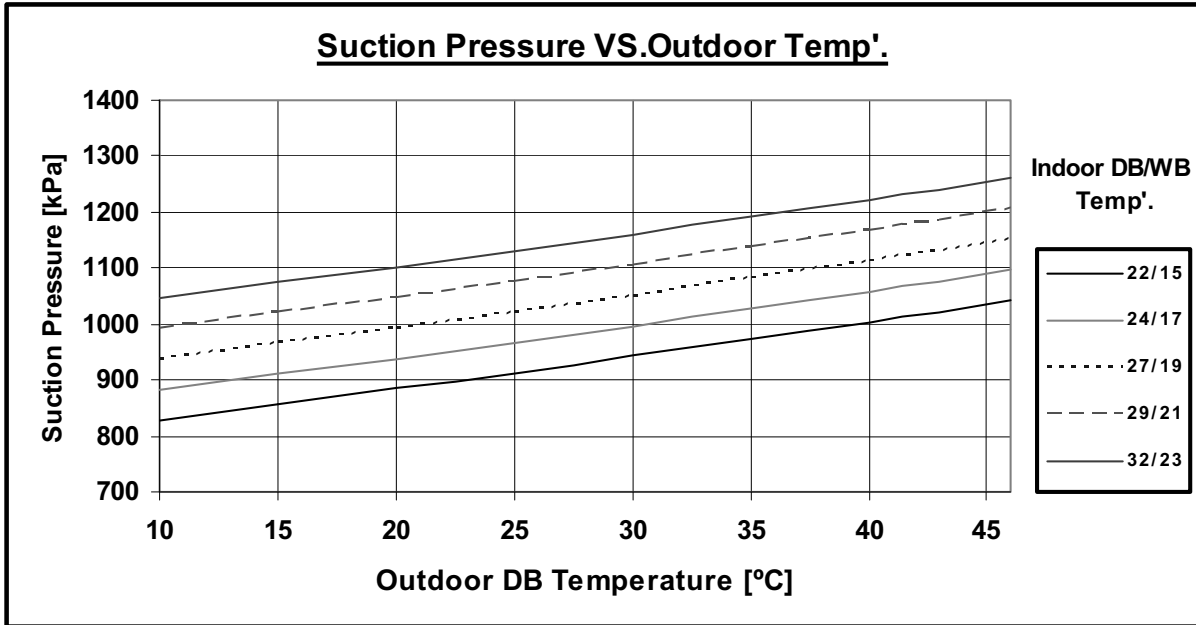

6.1.2 Heading – Test Mode

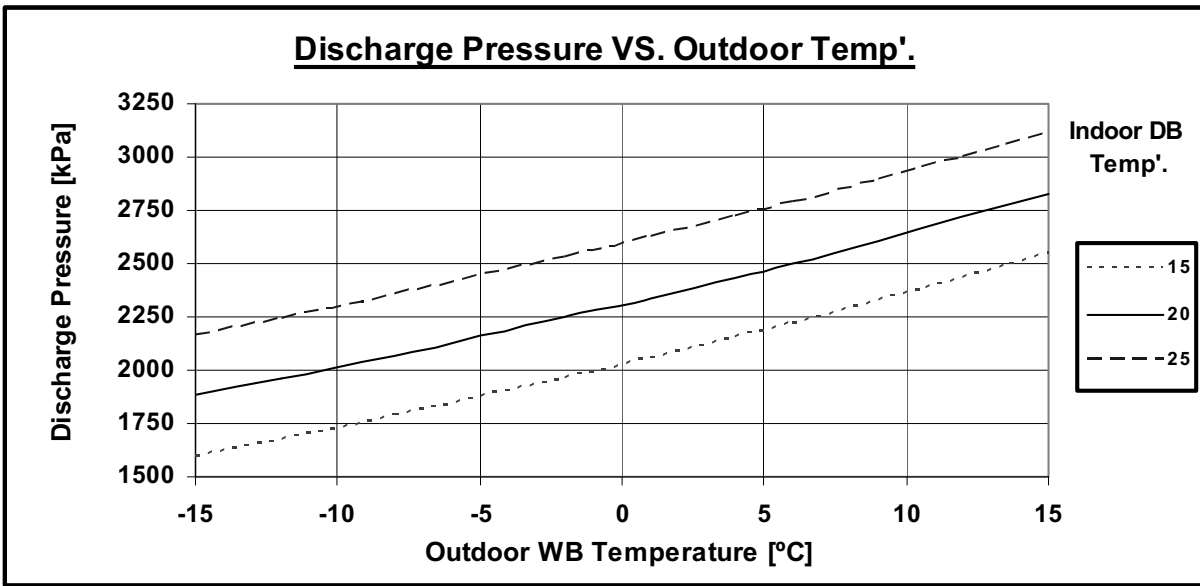
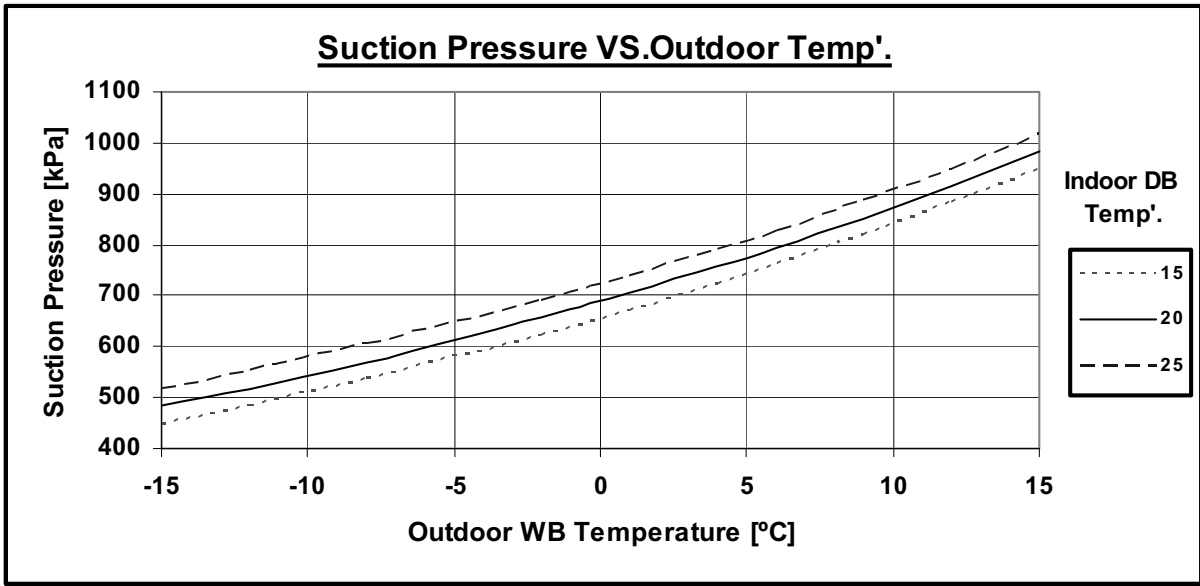

6.2 Model: WDI 9-12 DUO 38 DCI

6.2.1 Cooling – Test Mode

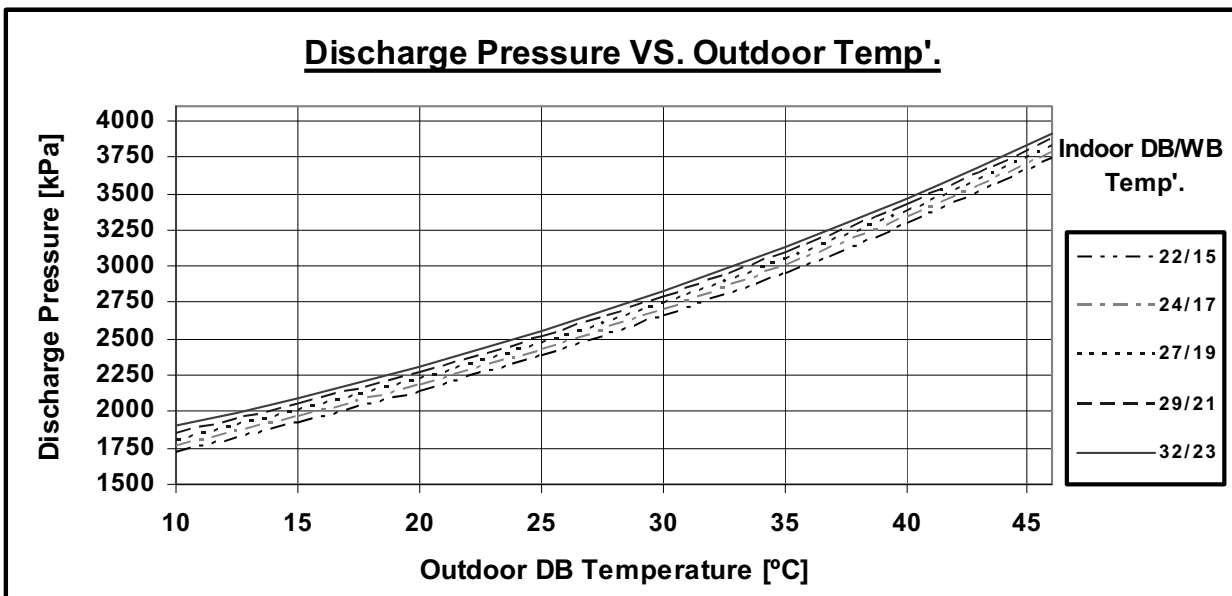
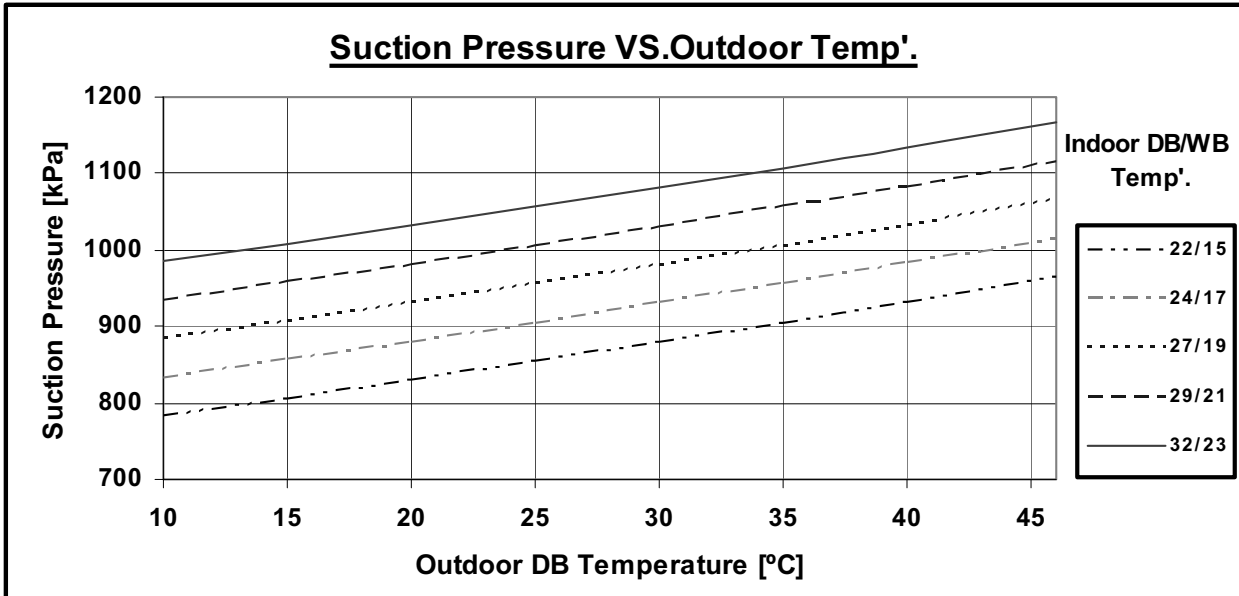

6.1.2 Heading – Test Mode

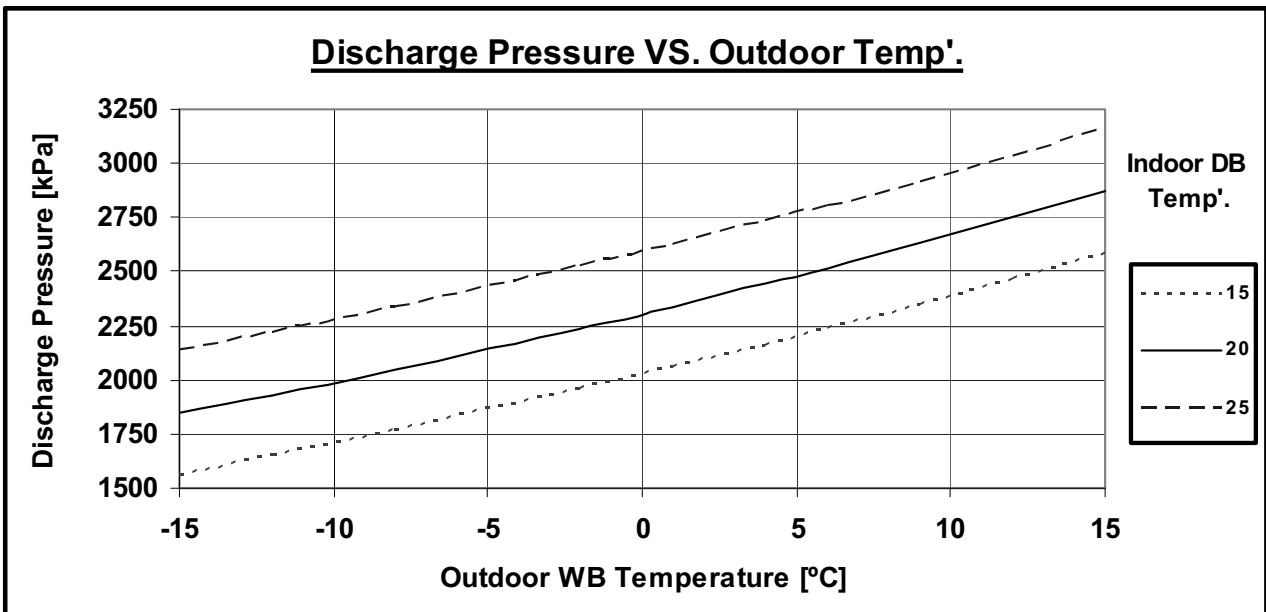
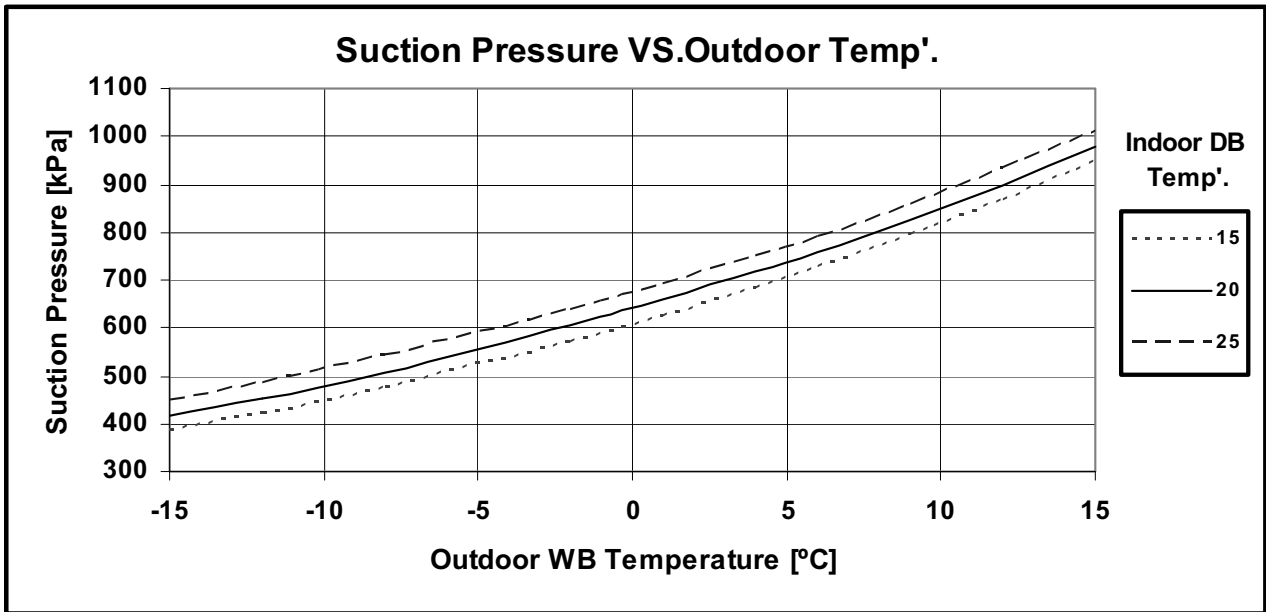

**7. ELECTRICAL DATA**

Power Supply	1 PH, 220-240 VAC, 50/60Hz
Connected to	Outdoor
Maximum Current	13.7 A
Inrush Current	35 A
Starting Current	10 A
Circuit breaker	16 A
Power supply wiring - No. x cross section	3 X 2.5 mm <sup>2</sup>
Interconnecting cable - No. x cross section	2 X 4 X 1.5 mm <sup>2</sup>

Note:

- Inrush current is the current when power is up. (charging the DC capacitors at outdoor unit controller).
- Starting current is the current when starting the compressor

**NOTE**

***Power wiring cord should comply with local laws and electrical regulations requirements.***

# 8. WIRING DIAGRAMS

## 8.1 DUO 38 DCI

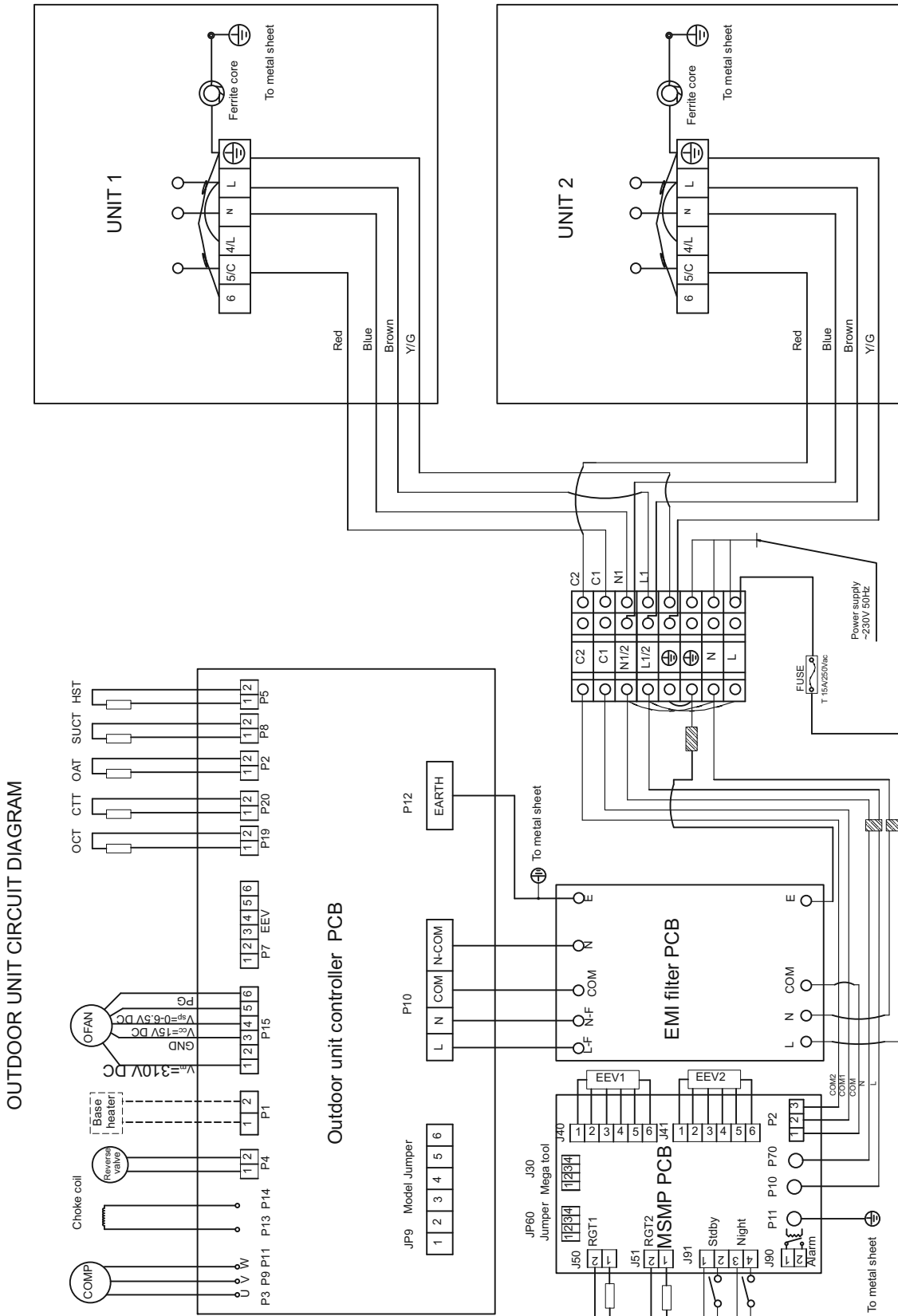

468600029

9. REFRIGERATION DIAGRAMS

9.1 Heat Pump Models

9.1.1 DUO 38 DCI => Cooling Mode

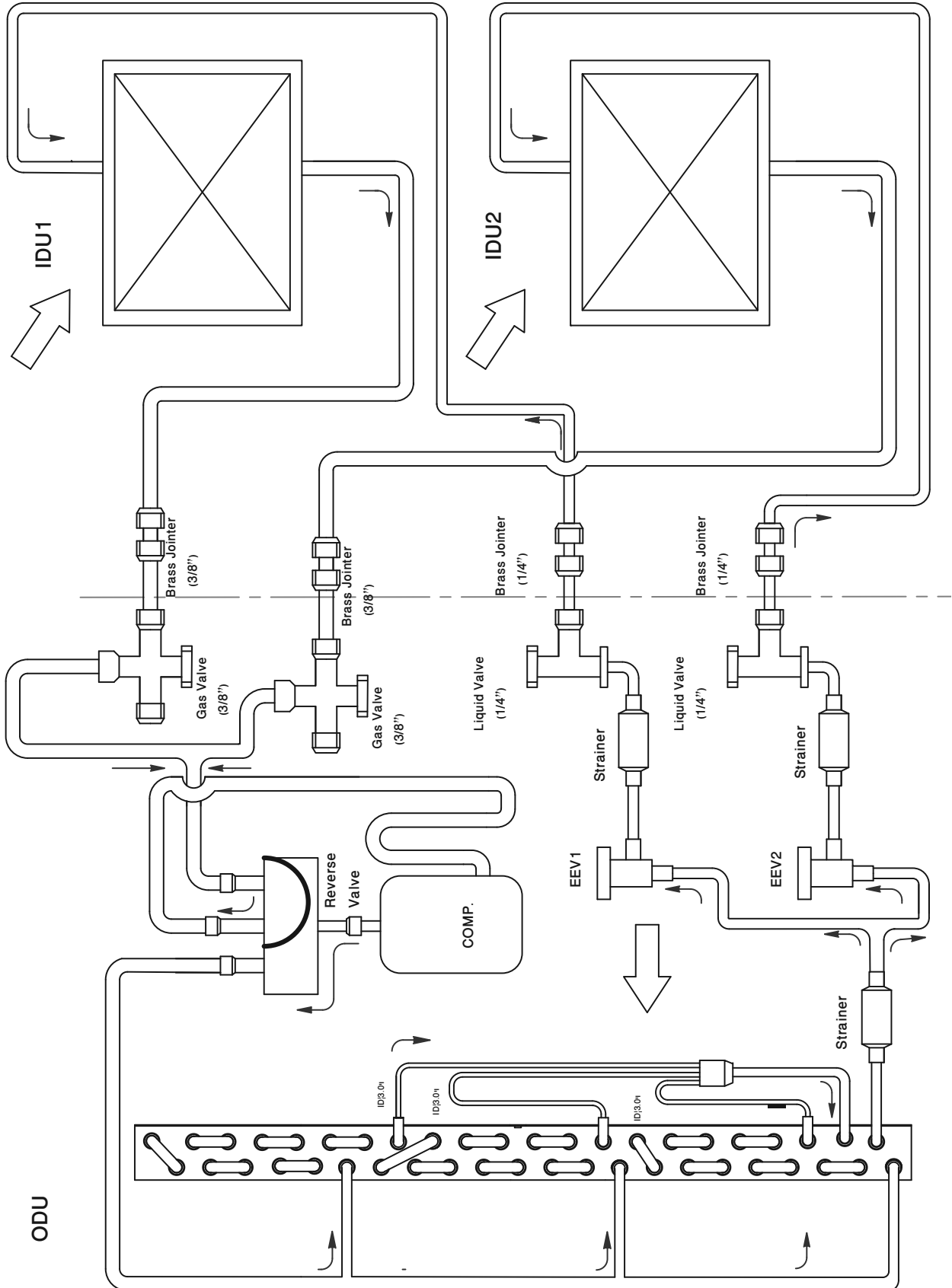



9.1.2 DUO 38 DCI => Heating Mode

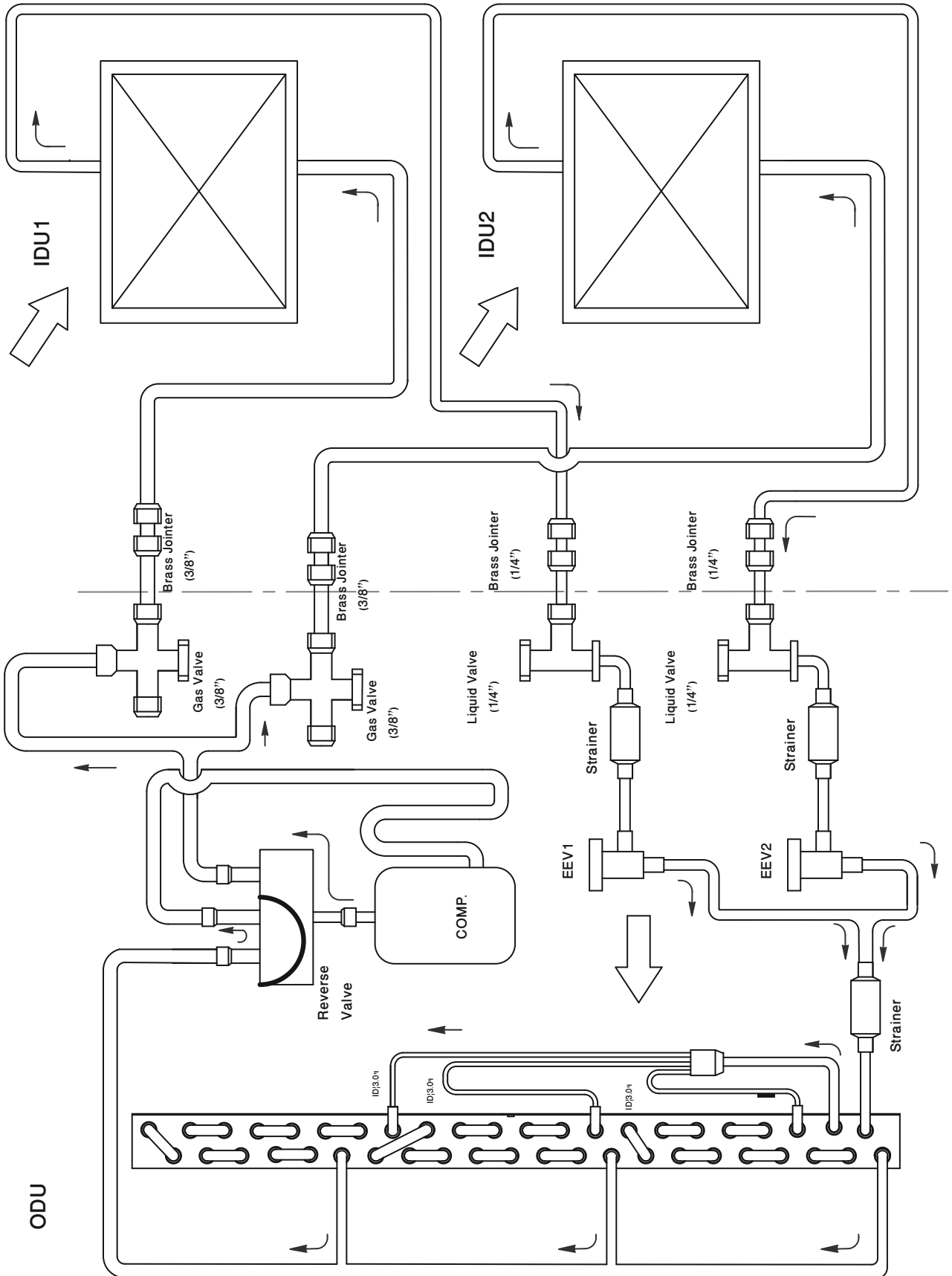

# 10. TUBING CONNECTIONS

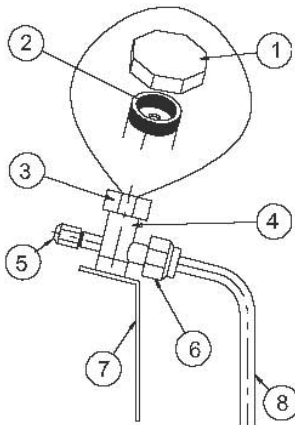
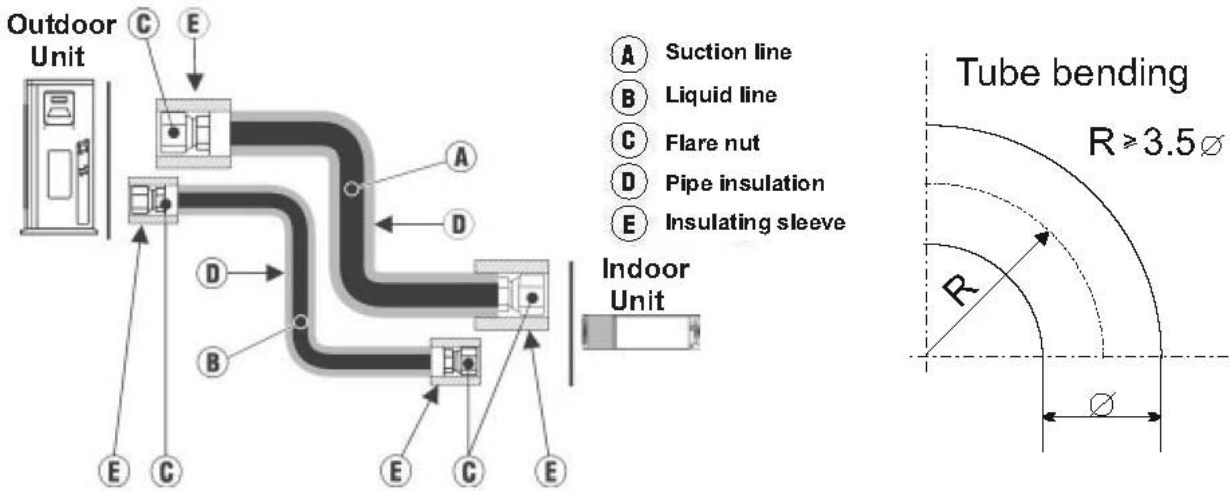

TUBE (Inch)	1/4"	3/8"	1/2"	5/8"	3/4"
<b>TORQUE (Nm)</b>					
<b>Flare Nuts</b>	11-13	40-45	60-65	70-75	80-85
<b>Valve Cap</b>	13-20	13-20	18-25	18-25	40-50
<b>Service Port Cap</b>	11-13	11-13	11-13	11-13	11-13

1. Valve Protection Cap-end
2. Refrigerant Valve Port (use Allen wrench to open/close)
3. Valve Protection Cap
4. Refrigerant Valve
5. Service Port Cap
6. Flare Nut
7. Unit Back Side
8. Copper Tube

When the outdoor unit is installed above the indoor unit an oil trap is required every 5m along the suction line at the lowest point of the riser. In case the indoor unit is installed above the outdoor, no trap is required.

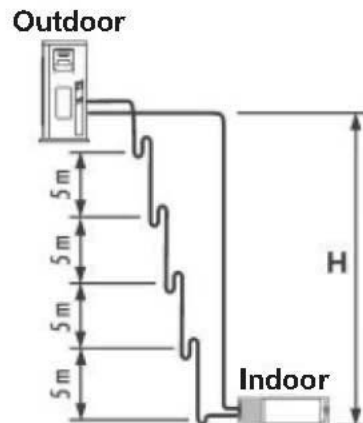

## 11. CONTROL SYSTEM

### 11.1 General Functions and Operating Rules (for single split models)

The DCI software is fully parametric.

All the model dependent parameters are shown in Blue color and with Italic style [*parameter*].

The parameters values are given in the last section of this control logic chapter of the service manual.

### 11.2 System Operation Concept

The control function is divided between indoor and outdoor unit controllers. Indoor unit is the system 'Master', requesting the outdoor unit for cooling/heating capacity supply. The outdoor unit is the system 'Slave' and it must supply the required capacity unless it enters into a protection mode avoiding it from supplying the requested capacity.

The capacity request is transferred via indoor to outdoor communication, and is represented by a parameter called 'NLOAD'. NLOAD is an integer number with values between 0 and 127, and it represents the heat or cool load felt by the indoor unit.

### 11.3 Compressor Frequency Control

#### 11.3.1 NLOAD setting

The NLOAD setting is done by the indoor unit controller, based on a PI control scheme. The actual NLOAD to be sent to the outdoor unit controller is based on the preliminary LOAD calculation, the indoor fan speed, and the power shedding function.

NLOAD limits as a function of indoor fan speed:

Indoor Fan Speed	Maximum NLOAD Cooling	Maximum NLOAD Heating
Low	<i>Max NLOADIF1C</i>	127
Medium	<i>Max NLOADIF2C</i>	127
High	<i>Max NLOADIF3C</i>	127
Turbo	<i>Max NLOADIF4C</i>	127
Auto	<i>Max NLOADIF5C</i>	127

NLOAD limits as a function of power shedding:

Mode	Power Shedding OFF	Power Shedding ON
Cool	No limit	Nominal Cooling
Heat	No limit	Nominal Heating

### 11.3.2 Target Frequency Setting

The compressor target frequency is a function of the NLOAD number sent from the indoor controller and the outdoor air temperature.

Basic Target Frequency Setting:

NLOAD	Target Frequency
127	Maximum frequency
10 < NLOAD < 127	Interpolated value between minimum and maximum frequency
10	Minimum frequency
0	Compressor is stopped

Target frequency limits as a function of outdoor air temperature (OAT):

OAT Range	Cool mode limits	Heat mode limits
OAT < 6	MaxFreqAsOATC	No limit
6 ≤ OAT < 15		MaxFreqAsOAT1H
15 ≤ OAT < 24		MaxFreqAsOAT2H
24 ≤ OAT	No limit	

### 11.3.3 Frequency Changes Control

Frequency change rate is 1 Hz/sec.

### 11.3.4 Compressor Starting Control

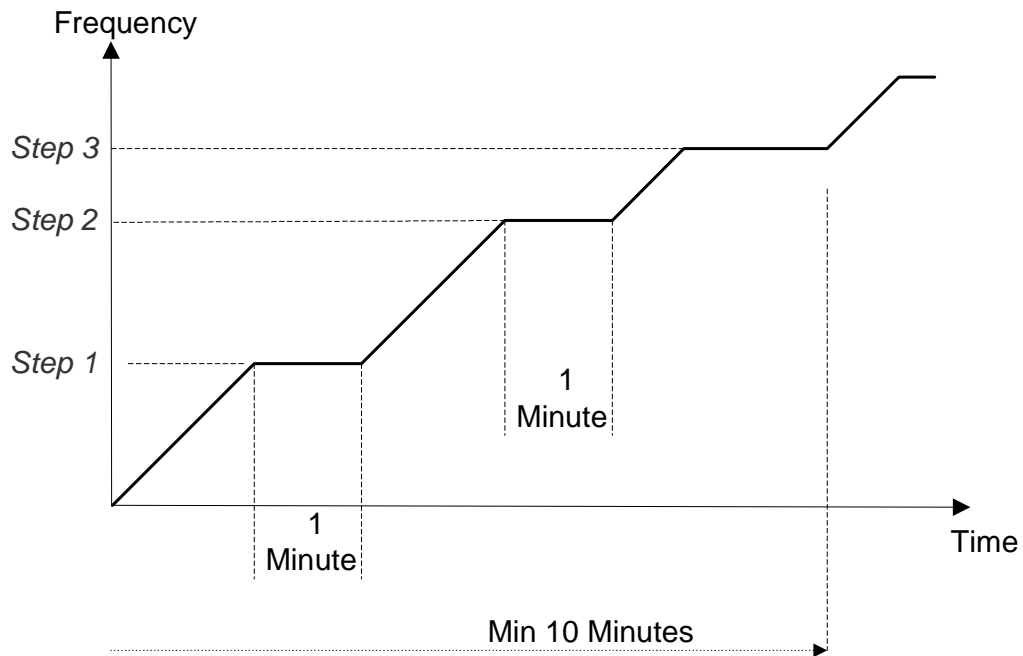

### 11.3.5 Minimum On and Off Time 3 minutes

## 11.4 Indoor Fan Control

10 Indoor fan speeds are determined for each model. 5 speeds for cool/dry/fan modes and 5 speeds for heat mode.

When user sets the indoor fan speed to a fixed speed (Low/ Medium/ High), unit will operate constantly at set speed.

When Auto Fan is selected, indoor unit controller can operate in all speeds. The actual speed is set according to the cool/heat load.

### 11.4.1 Turbo Speed

The Turbo speed is activated during the first 30 minutes of unit operation when auto fan speed is selected and under the following conditions:

- Difference between set point and actual room temperature is bigger then 3 degrees.
- Room temperature > 22 for cooling, or < 25 for heating.

## 11.5 Heating Element Control

Heating element can be started if  $LOAD > 0.8 * MaximumNLOAD$  AND Indoor Coil temperature < 45.

The heating element will be stopped when  $LOAD < 0.5 * MaximumNLOAD$  OR if Indoor Coil temperature > 50.

## 11.6 Outdoor Fan Control

7 outdoor fan speeds are determined for each model. 3 speeds for cool and dry modes, and 3 speeds for heat mode, and a very low speed.

Outdoor fan speed is a function of compressor frequency and outdoor air temperature (OAT).

4 routines for fan control are determined. The control routine selection depends on operation mode, compressor speed, and outdoor air temperature (OAT) and heat sink temperature (HST).

Routine	Conditions
A	Heating with OAT < 15°C or Cooling with OAT > 20°C, or HST > 50°C or Faulty OAT
B	Cooling with 20°C > OAT > 7°C
C	Cooling with 7°C > OAT
D	Heating with OAT > 15°C

Compressor Frequency (CF)	Outdoor Fan Speed			
	Routine A	Routine B	Routine C	Routine D
CF = 0	OFF	OFF	OFF	OFF
$10 \leq CF < OFLowFreq$	Low	Low	Very Low	Low
$OFLowFreq \leq CF < OFMedFreq$	Medium	Low	Very Low	Low
$OFMedFreq \leq CF$	High	Low	Low	Medium

When compressor is switched to OFF and the heat sink temperature is above 55 degrees, the outdoor fan will remain ON in low speed for up to 3 minutes.

## 11.7 EEV (electronic Expansion valve) Control

EEV opening is defined as  $EEV = EEV_{OL} + EEV_{CV}$

- $EEV_{OL}$  is the initial EEV opening as a function of the compressor frequency, operation mode, unit model and capacity.
- $EEV_{CV}$  is a correction value for the EEV opening that is based on the compressor temperature.
- During the first 10 minutes of compressor operation  $EEV_{CV} = 0$ .
- Once the first 10 minutes are over, the correction value is calculated as follow:  $EEV_{CV}(n) = EEV_{CV}(n-1) + EEV_{CTT}$
- $EEV_{CTT}$  is the correction based on the compressor temperature. A target compressor temperature is set depending on frequency and outdoor air temperature, and the actual compressor temperature is compared to the target temperature to set the required correction to the EEV opening.

## 11.8 Reversing Valve (RV) Control

Reversing valve is on in heat mode.

Switching of RV state is done only after compressor is off for over 3 minutes.

## 11.9 Ionizer Control

Ionizer is on when unit is on AND indoor fan is on AND Ionizer power switch (on Ionizer) is on.

## 11.10 Electro Static Filter (ESF) Control

ESF is on when ESF switch is on, Safety switch is pressed, unit is on, AND indoor fan is on.

## 11.11 Base Heater Control

When OAT is connected, Base Heater will be on when unit is in heating and  $OAT < 2^{\circ}C$ .

When OAT is disconnected, Base Heater will be on when unit is in heating.

## 11.12 Fan Mode

In high/ medium/ low indoor fan user setting, unit will operate fan in selected speed.

In Auto Fan user setting, fan speed will be adjusted automatically according to the difference between actual room temperature and user set point temperature.

## 11.13 Cool Mode

NLOAD is calculated according to the difference between actual room temperature and user set point temperature by PI control.

In high/ medium/ low indoor fan user setting, unit will operate fan in selected speed.

In Auto Fan user setting, fan speed will be adjusted automatically according to the calculated NLOAD.

### 11.14 Heat Mode

NLOAD is calculated according to the difference between actual room temperature and user set point temperature by PI control.

In high/ medium/ low indoor fan user setting, unit will operate fan in selected speed.

In AutoFan user setting, fan speed will be adjusted automatically according to the calculated NLOAD.

#### 11.14.1 Temperature Compensation

In wall mounted, ducted, and cassette models, 3 degrees are reduced from room temperature reading (except when in I-Feel mode), to compensate for temperature difference between high and low areas in the heated room, and for coil heat radiation on room thermistor.

The temperature compensation can be enabled/disabled by shortening of J2 on the indoor unit controller.

Model	J2 Shorted	J2 Opened
Wall mounted	Compensation Disabled	Compensation Enabled
Cassette	Compensation Enabled	Compensation Disabled
Ducted	Compensation Enabled	Compensation Disabled
Floor/Ceiling	Compensation Disabled	Compensation Enabled

#### 11.14.2 Indoor Fan Control in Heat Mode

Indoor fan speed depends on the indoor coil temperature:

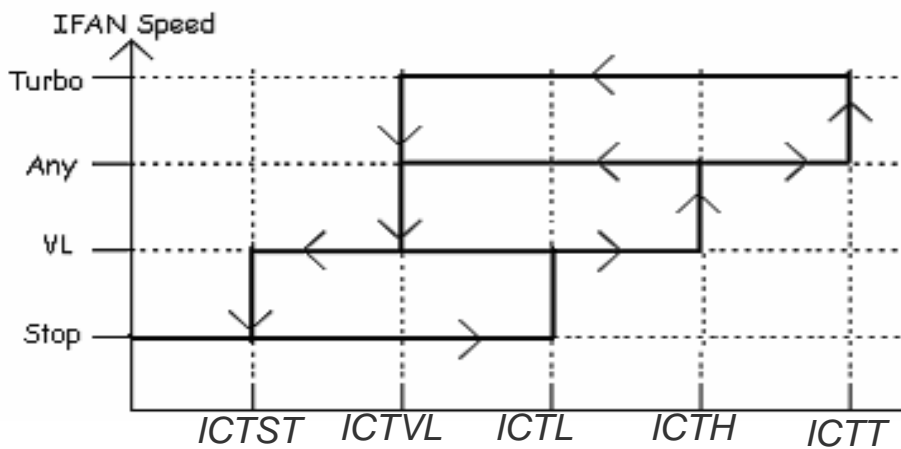

### 11.15 Auto Cool/Heat Mode

When in auto cool heat mode unit will automatically select between cool and heat mode according to the difference between actual room temperature and user set point temperature ( $\Delta T$ ).

Unit will switch from cool to heat when compressor is off for 3 minutes, and  $\Delta T < -3$ .

Unit will switch from heat to cool when compressor is off for 5 minutes, and  $\Delta T < -3$ .

### 11.16 Dry Mode

As long as room temperature is higher than the set point, indoor fan will work in low speed and compressor will work between 0 and *MaxNLOADIF1C* Hz.

When the room temperature is lower than the set point, compressor will be switched OFF and indoor fan will cycle 3 minutes OFF, 1 minute ON.

### 11.17 Protections

There are 5 protection codes.

Normal (Norm) – unit operate normally.

Stop Rise (SR) – compressor frequency can not be raised but does not have to be decreased.

HzDown1 (D1) – Compressor frequency is reduced by 2 to 5 Hz per minute.

HzDown2 (D2) – Compressor frequency is reduced by 5 to 10 Hz per minute.

Stop Compressor (SC) – Compressor is stopped.

#### 11.17.1 Indoor Coil Defrost Protection

ICT	ICT Trend				
	Fast Increasing	Increasing	No change	Decreasing	Fast Decreasing
ICT < -2	SC	SC	SC	SC	SC
-2 ≤ ICT < 0	D1	D1	D2	D2	D2
0 ≤ ICT < 2	SR	SR	D1	D2	D2
2 ≤ ICT < 4	SR	SR	SR	D1	D2
4 ≤ ICT < 6	Norm	Norm	SR	SR	D1
6 ≤ ICT < 8	Norm	Norm	Norm	SR	SR
8 ≤ ICT	Normal				

#### 11.17.2 Indoor Coil over Heating Protection

ICT	ICT Trend				
	Fast Decreasing	Decreasing	No Change	Increasing	Fast Increasing
ICT > 55	SC	SC	SC	SC	SC
53 < ICT ≤ 55	D1	D1	D2	D2	D2
49 < ICT ≤ 53	SR	SR	D1	D2	D2
47 < ICT ≤ 49	SR	SR	SR	D1	D2
45 < ICT ≤ 47	Norm	Norm	SR	SR	D1
43 < ICT ≤ 45	Norm	Norm	Norm	SR	SR
ICT ≤ 43	Normal				



**11.17.3 Compressor over Heating Protection**

Compressor temperature can be in one of 5 control zones (4 in protection, and 1 normal), t.

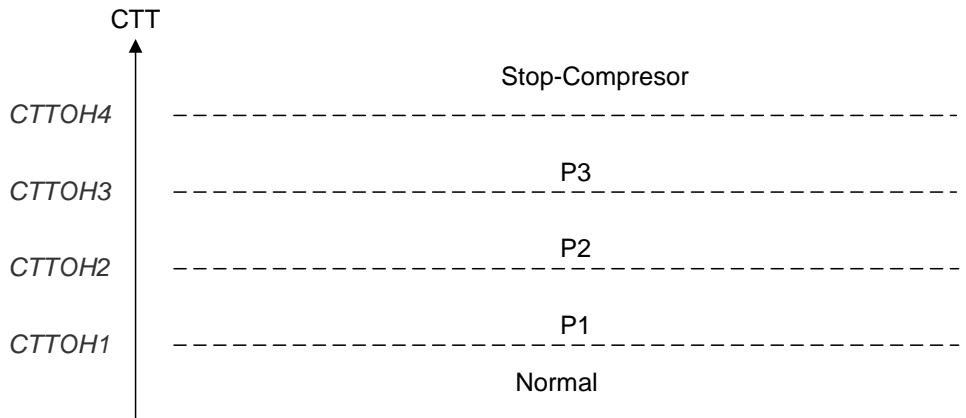

Control Status	Compressor Temperature Increases	Else
P1	Norm	SR
P2	D1	SR
P3	D2	D1
Stop Compressor	SC	

**11.17.4 Compressor over Current Protection**

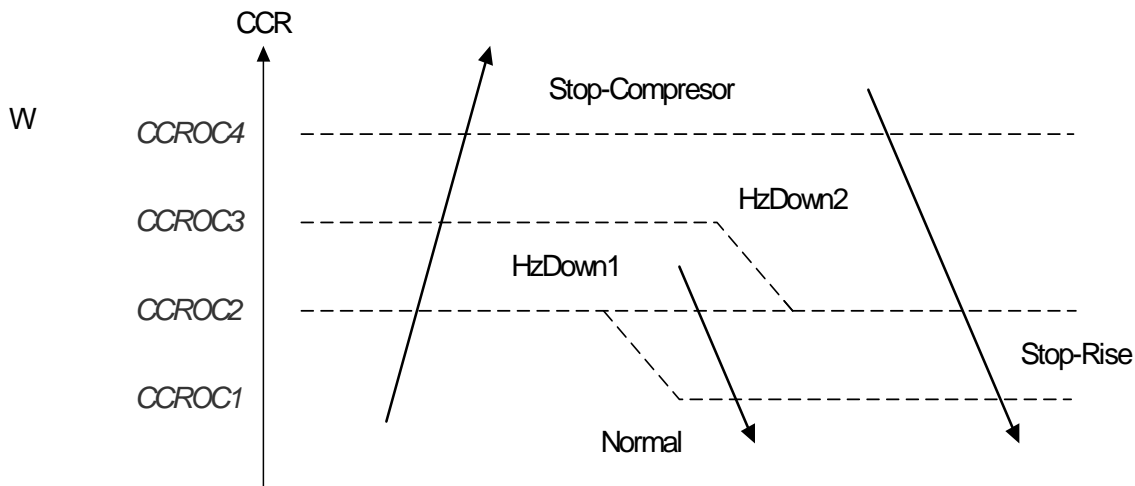

**11.17.5 Heat Sink Over Heating Protection (NA for DCI 25 and 35)**

HST	HST Trend		
	Decreasing	No Change	Increasing
HST > 90	SC	SC	SC
85 < HST ≤ 90	D1	D2	D2
82 < HST ≤ 85	SR	D1	D2
80 < HST ≤ 82	SR	SR	D1
78 < HST ≤ 80	Norm	Norm	SR
HST ≤ 78	Normal		

**11.17.6 Outdoor Coil Deicing Protection****11.17.6.1 Deicing Starting Conditions**

Deicing operation will start when either one of the following conditions exist:

- Case 1: OCT < OAT – 8 AND TLD > DI
- Case 2: OCT < OAT – 12 AND TLD > 30 minutes.
- Case 3: OCT is Invalid AND TLD > DI
- Case 4: Unit is just switched to STBY AND OCT < OAT – 8
- Case 5: NLOAD = 0 AND OCT < OAT -8

OCT – Outdoor Coil Temperature

OAT – Outdoor Air Temperature

TLD – Time from Last Deicing

DI – Deicing Interval (Time Interval between Two Deicing)

Deicing interval time when compressor is first started in heat mode, is 10 minutes if OCT < -2, and is 40 minutes in other cases.

Deicing interval time is changed (increased/ decreased in 10 minutes steps) as a function of deicing time. If deicing time is shorter than former deicing time, the deicing interval time will be increased. If deicing time is longer than former deicing time, the deicing interval time will be decreased.

11.17.6.2 Deicing Protection Procedure

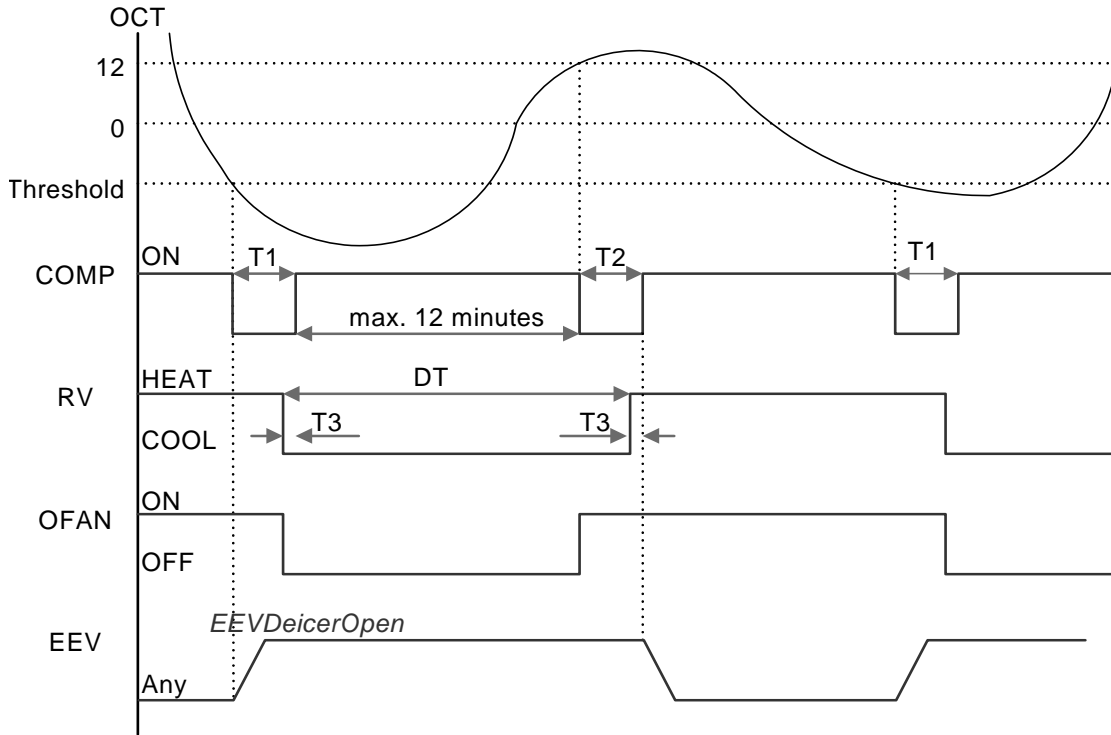

$T_1 = T_2 = 36$  seconds,  $T_3 = 6$  seconds

11.17.7 Condensate Water Over Flow Protection

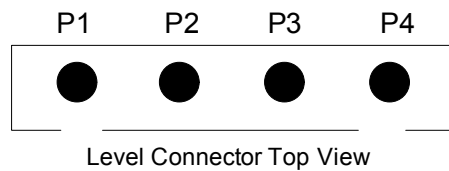

Each of the pins P1, P2, P3 can have two options:

- 1 – When it is shorted with P4
- 0 – When it is not shorted to P4

11.17.7.1 Levels Logic (used in floor/ceiling models)

P2	P3	Level
0	0	L0
1	0	L1
1	1	L2&3
0	1	L4

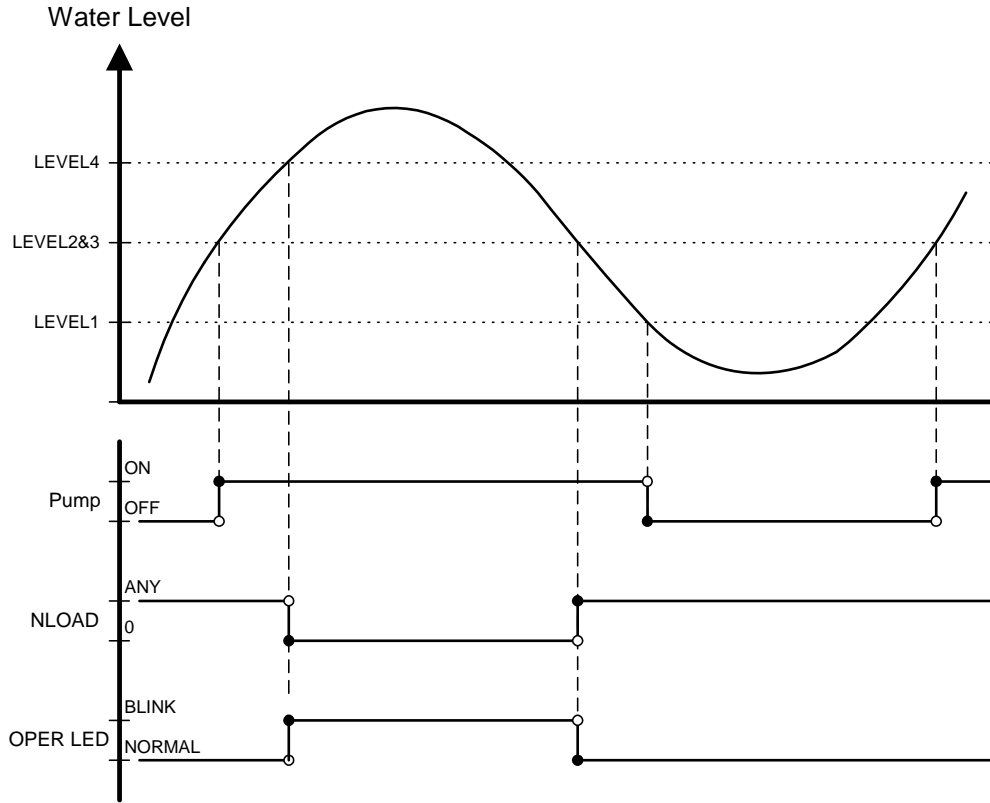

**11.17.7.2 1 Level Logic (used in all models except for floor/ceiling models)**

P2	P3	Level
Don't care	1	Normal
Don't care	0	Overflow

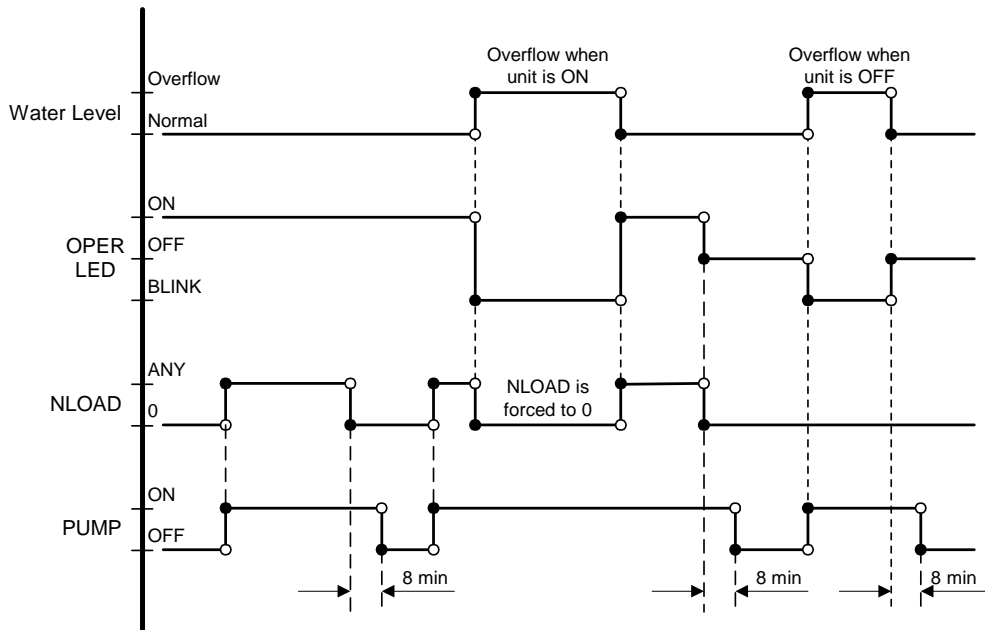

### 11.18 Indoor Unit Dry Contact

Indoor unit Dry contact has two alternative functions that are selected by J8.

Function		Contact = Open	Contact = Short
J8 = Open	Presence Detector Connection	No Limit	Forced to STBY
J8 = Short	Power Shedding Function	No Limit	Limit NLOAD

### 11.19 Operating the Unit from the Mode Button

Forced operation allows starting, stopping and operating in Cooling or Heating, in pre-set temperature according to the following table:

Forced operation Mode	Pre-set Temperature
Cooling	20°C
Heating	28°C

### 11.20 On Unit Controls and Indicators

#### 11.20.1 Indoor Unit Controller Controls and Indicators for All Models Except for Floor/Ceiling model

<b>STAND BY INDICATOR</b>	1. Lights up when the Air Conditioner is connected to power and ready to receive the R/C commands
<b>OPERATION INDICATOR</b>	1. Lights up during operation. 2. Blinks for 300 msec., to announce that a R/C infrared signal has been received and stored. 3. Blinks continuously during protections (according to the relevant spec section).
<b>TIMER INDICATOR</b>	Lights up during Timer and Sleep operation.
<b>FILTER INDICATOR</b>	Lights up when Air Filter needs to be cleaned.
<b>COOLING INDICATOR</b>	Lights up when system is switched to Cool Mode by using the Mode Switch <u>on the unit</u> .
<b>HEATING INDICATOR</b>	Lights up when system is switched Heat Mode by using the Mode Switch <u>on the unit</u> .
<b>Mode SWITCH (COOL/HEAT/OFF)</b>	Every short pressing , the next operation mode is selected, in this order : SB → Cool Mode → Heat Mode → SB → ... In long pressing system enters diagnostic mode.
<b>RESET / FILTER SWITCH</b>	For short pressing: When Filter LED is on - turn off the FILTER INDICATOR after a clean filter has been reinstalled. When Filter LED is off – enable/disable the buzzer announcer, if selected.

**11.20.2 Indoor Unit Controls and Indicators for LCD Display**

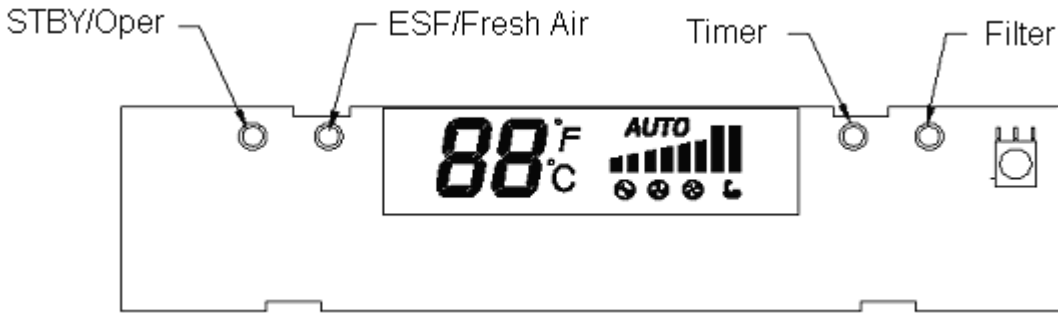

	STBY	Cool	Heat	Auto	Fan	Dry
<b>88</b>	OFF	SPT(1*)	SPT(1*)	SPT(1*)	SPT(1*)	SPT(1*)
<b>°C</b>	OFF(2*)	ON(2*)	ON(2*)	ON(2*)	ON(2*)	ON(2*)
<b>°F</b>	OFF(2*)	OFF(2*)	OFF(2*)	OFF(2*)	OFF(2*)	OFF(2*)
(Low)	OFF	User setting IFAN speed	User setting IFAN speed	User setting IFAN speed	User setting IFAN speed	User setting IFAN speed
(Med)	OFF					
(High)	OFF					
(Turbo)	OFF					
<b>AUTO</b> (Auto)	OFF					
<b>Backlight(red)</b>	OFF	OFF	ON(3*)	ON(3*)	ON(3*)	OFF
<b>Backlight(green)</b>	OFF	ON(3*)	OFF	ON(3*)	ON(3*)	ON(3*)

**11.20.3 Outdoor Unit Controller Indicators**

Unit has three LED's.

SB LED is ON when power is ON (230 VAC, even when no communication).

STATUS LED is ON when COMP is ON, and Blinks according to diagnostics mode definitions when either fault or protection occurs.

FAULT LED Blinks according to diagnostics mode definitions when either fault or protection occurs.

## 11.21 Jumper Settings

### 11.21.1 Indoor Unit Controller

0 = Open Jumper (disconnect jumper).

1 = Close Jumper (connect jumper).

Self test Jumper – J1

<b>OPERATION</b>	J1
<b>SELF-TEST</b>	1
<b>NORMAL</b>	0

### Compensation Jumper – J2

Model	J2 (Default)	Compensation
Wall Mounted	0	Activated
Floor/Ceiling	1	Deactivated
Ducted/cassette	1	Activated

### Family selection Jumper – J3, J4 and J5

Family	J5	J4	J3
Reserved	0	0	0
Reserved	0	0	1
Reserved	0	1	0
Wall Mounted (WNG/FLO)	0	1	1
Floor/Ceiling (PXD)	1	0	0
Reserved	1	0	1
Ducted (LS)	1	1	0
Cassette (K)	1	1	1

IDU Model	Jumper Setting					
	J8	J7	J6	J5	J4	J3
<b>WNG25</b>	0	0	0	0	1	1
<b>WNG35</b>	0	1	0	0	1	1
<b>WNG50</b>	0	0	1	0	0	0
<b>WNG60</b>	0	1	1	0	0	0
<b>WNG80</b>	0	0	1	0	0	1
<b>PXD25</b>	0	0	0	1	0	0
<b>PXD35</b>	0	1	0	1	0	0
<b>PXD50</b>	1	0	0	1	0	0
<b>K25</b>	0	0	0	1	1	1
<b>K35</b>	0	1	0	1	1	1
<b>K50</b>	1	0	0	1	1	1
<b>LS35</b>	0	1	0	1	1	0

For wall mounted units Jumpers j7, j8 can be configured by service. All other jumpers on the above table are factory default (cannot be changed by service).

For unit types as Cassettes, floor ceiling, and ducted, jumpers are set by a model plug.

**Model selection Jumper – J6, J7**

Model	J7	J6
9000 Btu/hr	0	0
12000 Btu/hr	0	1
18000 Btu/hr	1	0
24000 Btu/hr	1	1

**J8- Clock/Power Shedding**

Operation	J8
Clock	0
Power Shedding	1

**J9 – IFAN Cycling Disabling**

Display Mode (wall mounted units only)	J9
LCD	0
LED	1

**11.21.2 Outdoor Unit Controller**

**11.21.2.1 JP9 JUMPER LAYOUT**

Reserved (PIN 9)	ODU3 (PIN 7)	ODU2 (PIN 5)	ODU1 (PIN 3)	ODU0 (PIN 1)
GND (PIN 10)	GND (PIN 8)	GND (PIN 6)	GND (PIN 4)	GND (PIN 2)

**11.21.3 ODU MODEL SELECTION**

ODU3	ODU2	ODU1	ODU0	ODU Model
OFF	OFF	OFF	OFF	Reserved
OFF	OFF	OFF	ON (PIN1 & PIN2)	A (DCI 25)
OFF	OFF	ON (PIN3 & PIN4)	OFF	B (DCI 35)
OFF	OFF	ON (PIN3 & PIN4)	ON (PIN1 & PIN2)	C (DCI 50)
OFF	ON (PIN5 & PIN6)	OFF	OFF	D
OFF	ON (PIN5 & PIN6)	OFF	ON (PIN1 & PIN2)	E (Duo)
OFF	ON (PIN5 & PIN6)	ON (PIN3 & PIN4)	OFF	F
OFF	ON (PIN5 & PIN6)	ON (PIN3 & PIN4)	ON (PIN1 & PIN2)	G
ON (PIN7 & PIN8)	OFF	OFF	OFF	H
ON (PIN7 & PIN8)	OFF	OFF	ON (PIN1 & PIN2)	I
ON (PIN7 & PIN8)	OFF	ON (PIN3 & PIN4)	OFF	J
ON (PIN7 & PIN8)	OFF	ON (PIN3 & PIN4)	ON (PIN1 & PIN2)	K
ON (PIN7 & PIN8)	ON (PIN5 & PIN6)	OFF	OFF	L
ON (PIN7 & PIN8)	ON (PIN5 & PIN6)	OFF	ON (PIN1 & PIN2)	M
ON (PIN7 & PIN8)	ON (PIN5 & PIN6)	ON (PIN3 & PIN4)	OFF	N
ON (PIN7 & PIN8)	ON (PIN5 & PIN6)	ON (PIN3 & PIN4)	ON (PIN1 & PIN2)	O



## 11.22 Test Mode

### 11.22.1 Entering Test Mode

System can enter Test mode in two ways:

- Automatically when the following conditions exists for 30 minutes continuously:
  - Mode = Cool, Set point = 16, Room temperature =  $27\pm 1$ , Outdoor temperature =  $35\pm 1$

Or

- Mode = Heat, Set point = 30, Room temperature =  $20\pm 1$ , Outdoor temperature =  $7\pm 1$
- Manually when entering diagnostics with the following settings:
  - Mode = Cool, Set point = 16
  - Mode = Heat, Set point = 30

### 11.22.2 Unit Operation in Test Mode

In test mode, the unit will operate in fixed settings according to the indoor fan speed setting :

Indoor Fan Speed Setting	Unit Setting
Low	Minimum Capacity Setting
High	Nominal Capacity Setting
Auto	Maximum Capacity Setting

During test mode, protections are disabled, except for stop compressor status.

## 11.23 Additional Functions and Operating Rules (for DUAL split models)

The DCI SW is fully parametric.

All the model dependent parameters are shown in Blue color and with Italic style [*parameter*].

The parameters values are given in the last section of this control logic chapter of the service manual.

### 11.23.1 System Control Concept

All indoor unit related items control remains the same as in single split applications.

All outdoor unit related control logic remains the same as in single split applications.

The MSMP controller is responsible only for the following control:

- Setting of system operation mode (cool/heat)
- Setting the NLOAD for the outdoor units
- Controlling of the EEV's
- Dry contacts control

### 11.23.2 Compressor Frequency Control

### 11.23.3 Outdoor Unit NLOAD setting

The MSMP controller gets the NLOAD from each of the indoor units, and sends a combined NLOAD to the outdoor unit control. The combined NLOAD is a weighted average of the indoor units NLOAD.

The weight of the indoor units as a function of their nominal capacity:

Indoor Unit Capacity [kW] (kBtu/hr)	Capacity Code
2.5 (9000)	1
3.5 (12000)	1.5
5.0 (18000)	2
7.2 (24000)	3

**11.23.4 EEV (electronic Expansion valve) Control**

EEV opening is defined as  $EEV = EEV_{OL} + EEV_{CV}$

- $EEV_{OL}$  is the initial EEV opening as a function of the compressor frequency, operation mode, unit model and capacity.
- $EEV_{CV}$  is a correction value for the EEV opening that is based in cooling mode on the relevant indoor unit super heat and compressor temperature.
- During the first 10 minutes of compressor operation  $EEV_{CV} = 0$ .

**11.23.5 System Mode Setting and Reversing Valve (RV) Control**

The first indoor unit that is causing the system to be turned ON sets the system mode.

**11.23.6 Indoor Units Operation when Indoor Unit Mode is Different than Outdoor Unit Mode**

- Open louvers according to user selection.
- Indoor fan is forced to OFF.

**11.24 Dry Contacts Control**

Dry Contact	Contact = Open	Contact = Short
STBY	No Limit	System is Forced to STBY
Night	No Limit	Outdoor fan speed reduced to low in cooling mode

A dry contact output for Alarm will be shorted when any failure exists in the system.

## 11.25 SW Parameters

### 11.25.1 Indoor Units SW Parameters

General Parameters for All Models:

**Parameters defining the indoor fan speed as a function of Indoor Coil temperature in heat mode (ICT):**

ICTST Speed	ICT to stop indoor fan	25
ICTVLSpeed	ICT to go down to very low speed	28
ICTLSpeed	ICT to start in very low speed	30
ICTHSpeed	ICT to start in increase speed from very low	32
ICTTSpeed	ICT to enable Turbo fan speed	40

Model Depended Parameters:

Parameter name	Wall Mounted Models			
	DCI 25	DCI 35		
<b>NLOAD limits as a function of selected indoor fan speed</b>				
MaxNLOADIF1C	40	40		
MaxNLOADIF2C	53	53		
MaxNLOADIF3C	120	120		
MaxNLOADIF4C	127	127		
MaxNLOADIF5C	127	127		
<b>Indoor Fan speeds</b>				
IFVLOWC	700	700		
IFLOWC	800	800		
IFMEDC	900	950		
IFHIGHC	1050	1100		
IFTURBOC	1150	1200		
IFVLOWH	700	700		
IFLOWH	800	850		
IFMEDH	950	1000		
IFHIGHH	1100	1150		
IFTURBOH	1200	1250		
<b>Nominal Compressor Frequency</b>				
NomLoadC	40	62		
NomLoadH	55	67		
Parameter Name	Cassette Models			
	K 25	K 35	K 35S	K 50
<b>NLOAD limits as a function of selected indoor fan speed</b>				
MaxNLOADIF1C	40	40	40	40
MaxNLOADIF2C	53	56	56	60
MaxNLOADIF3C	120	90	90	90
MaxNLOADIF4C	127	90	90	90
MaxNLOADIF5C	127	90	90	90
<b>Nominal Compressor Frequency</b>				
NomLoadC	40	60	56	63
NomLoadH	55	69	73	80

## 11.25.2 Outdoor Units SW Parameters:

Parameter Name	DCI25	DCI35	DCI 50	DCI50 DUO
<b>Compressor Parameters</b>				
MinFreqC	30	33	20	20
MaxFreqC	64	80	85	97
MinFreqH	30	35	20	26
MaxFreqH	81	93	99	106
Step1Freq	60	60	60	60
Step2Freq	70	70	70	80
Step3Freq	90	90	90	90
<b>Frequency limits as a function of outdoor air temperature</b>				
MaxFreqAsOATC	50	50	64	62
MaxFreqAsOAT1H	65	75	85	85
MaxFreqAsOAT2H	60	60	60	60
<b>Compressor Over Heating Protection</b>				
CTTOH1	94	94	94	90
CTTOH2	98	98	98	95
CTTOH3	102	102	102	102
CTTOH4	105	105	105	105
<b>Compressor Over Current Protection [A]</b>				
CCR01	7.1	7.1	10	10
CCR02	7.5	7.5	10.5	10.5
CCR03	7.9	7.9	10.8	10.8
CCR04	8.3	8.3	11.2	11.2
<b>Outdoor Fan Speed (RPM)</b>				
VL	200	200	200	200
OFLOWC	550	550	600	600
OFMEDC	700	700	760	830
OFMAXC	830	830	920	920
OFLOWH	550	550	600	600
OFMEDH	700	700	830	920
OFMAXH	830	830	1000	1000
<b>Outdoor Fan Limit Control</b>				
OFLowFreq	45	45	40	40
OFMedFreq	57	57	70	70

## 12. TROUBLESHOOTING

### **WARNING!!!**

When Power Up – the whole outdoor unit controller, including the wiring, is under HIGH VOLTAGE!!!

Never open the Outdoor unit before turning off the Power!!!

When turned off, the system is still charged (400V)!!!

It takes about 3 Min. to discharge the system.

Touching the controller before discharging may cause an electrical shock!!!

**For safe handling of the controller please refer to section 1.6 below.**

### 1.1 Dual Split System Failures and Corrective Actions

No	SYMPTOM	PROBABLE CAUSE	CORRECTIVE ACTION
1	Power supply indicator at indoor unit (Red LED) does not light up.	No power supply	Check power supply from the outdoor. If power supply is OK, check display and display wiring. If OK, replace controller.
2	Indoor fan does not start (louvers are opened and Green LED does light up)	Unit in heat mode and coil is still not warm.	Change to cool mode and check.
		The outdoor unit is in the opposite mode.	Change operation mode and check if fan starts.
		Problem with PCB or capacitor	Change to high speed and Check power supply to motor is higher than 130VAC (for Triac controlled motor) or higher than 220VAC for fixed speed motors, if OK replace capacitor, if not OK replace controller
3	Compressor does not start	Jumper settings of outdoor unit is not correct	Use diagnostics (see 1.2 below) information on MSMP board.
4	One indoor is operating, in cool mode, with no capacity, and the other unit has water leaks/freezing problems	The communication wires of the two indoor units are switched	Check and correct the communication wires connection
5	One indoor is operating in heat mode with a limited capacity, and the coil on the other unit is very hot.		
6	Compressor operate but unit generate no capacity	EEV is stuck in close position	Check EEV
7	One unit only is operating	Communication problems	Use diagnostics information on MSMP board (see 1.2 below).
8	All others	Specific problems of indoor or outdoor units	Use diagnostics information on MSMP board (see 1.2 below), and perform action items as recommended in single split systems

## 1.2 Checking the refrigeration system

Checking system pressures and other thermodynamic measures should be done when system is in Test Mode (in Test mode, system operates in fixed settings). The performance curves given in this manual are given for unit performance in test mode when high indoor fan speed is selected.

Entering test mode:

Set the two indoor units to Cool/16 degrees/High indoor fan speed, or Heat/30 degrees/High indoor fan speed, and enter diagnostics. Note: the two indoor units should be set to the same mode and fan speed.

## 1.3 Judgment by MSMP Diagnostics

The MSMP controller has 11 LED's (1 STBY LED, 5 Unit LEDs and 5 Status/Fault LEDs).

STBY LED is ON when power is ON.

5 Unit LEDs refer to four Indoor units and one Outdoor unit. They will turn on one at a time and the corresponding Indoor/Outdoor unit status/fault code will be displayed on the Status/Fault LEDs. If the unit is normal (no fault), the unit LED and the corresponding status will be displayed for 5 seconds and move to the next unit LED. On the other hand, if the unit is in fault, the unit LED and the corresponding fault will be displayed for 10 seconds, and hence more time to read the fault code.

### 1.3.1 MSMP Fault Code for Outdoor unit:

No	Problem	5	4	3	2	1
1	OCT is disconnected	0	0	0	0	1
2	OCT is shorted	0	0	0	1	0
3	CTT is disconnected	0	0	0	1	1
4	CTT is shorted	0	0	1	0	0
5	HST is disconnected (when enabled)	0	0	1	0	1
6	HST is shorted (when enabled)	0	0	1	1	0
7	OAT is disconnected (when enabled)	0	0	1	1	1
8	OAT is shorted (when enabled)	0	1	0	0	0
9	TSUC is disconnected (when enabled)	0	1	0	0	1
10	TSUC is shorted (when enabled)	0	1	0	1	0
11	IPM	0	1	0	1	1
12	Bad Outdoor unit EEPROM	0	1	1	0	0
13	DC under voltage	0	1	1	0	1
14	DC over voltage	0	1	1	1	0
15	AC under voltage	0	1	1	1	1
16	Indoor / Outdoor unit Communication mismatch	1	0	0	0	0
17	No Communication	1	0	0	0	1
18	Illegal Outdoor unit Model	1	0	0	1	0
19	Bad MSMP EEPROM	1	0	0	1	1
20	Heat sink Over Heating	1	0	1	0	0
21	Deicing	1	0	1	0	1
22	Compressor Over Heating	1	0	1	1	0
23	Compressor Over Current	1	0	1	1	1
....	Reserved					
27	Bad Communication	1	1	0	1	1
...	Reserved					
29	No Fault (Heat Mode)	1	1	1	0	1
30	No Fault (Cool, Dry, Fan Mode)	1	1	1	1	0
31	No Fault (Stand By)	1	1	1	1	1

### 1.3.2 Outdoor unit diagnosis by MSMP and corrective actions

No.	Fault	Probable Cause	Corrective Action
1	Sensors failures of all types		Check sensors connections or replace sensors.
2	IPM Fault	Electronics HW problem	Check all wiring and jumper settings, if OK, replace electronics.
3	Bad EEPROM		No action, unless special parameters are required for unit operation.
4	DC under/over Voltage	Electronics HW problem	Check outdoor unit power supply voltage
5	AC under Voltage		Check outdoor unit power supply voltage
6	Indoor / Outdoor unit Communication mismatch	Indoor and Outdoor controllers are with different versions	Replace Indoor controller
7	No Communication	Communication or grounding wiring is not good.	Check Indoor to Outdoor wiring and grounding
8	Compressor Lock		Switch unit to STBY and restart
9	Bad Communication	Communication quality is low reliability	Check Indoor to Outdoor wiring and grounding

## 1.3.3 MSMP Fault Code for Indoor unit:

No	Problem	5	4	3	2	1
1	RT-1 is disconnected	0	0	0	0	1
2	RT-1 is shorted	0	0	0	1	0
3	RT-2 is disconnected	0	0	0	1	1
4	RT-2 is shorted	0	0	1	0	0
5	RGT is disconnected	0	0	1	0	1
6	Reserved	0	0	1	1	0
7	Communication mismatch	0	0	1	1	1
8	No Communication	0	1	0	0	0
9	No Encoder	0	1	0	0	1
10	Reserved	0	1	0	1	0
11	Outdoor unit fault	0	1	0	1	1
12	Reserved	0	1	1	0	0
13	Reserved.	0	1	1	0	1
14	Reserved	0	1	1	1	0
15	Reserved	0	1	1	1	1
17	Defrost protection	1	0	0	0	1
18	Deicing Protection	1	0	0	1	0
19	Outdoor Unit Protection	1	0	0	1	1
20	Indoor Coil HP Protection	1	0	1	0	0
21	Overflow Protection	1	0	1	0	1
22	Reserved	1	0	1	1	0
23	Reserved	1	0	1	1	1
24	EEPROM Not Updated	1	1	0	0	0
25	Bad EEPROM	1	1	0	0	1
26	Bad Communication	1	1	0	1	0
27	Using EEPROM data	1	1	0	1	1
29	No Fault (Heat Mode)	1	1	1	0	1
30	No Fault (Cool, Dry, Fan Mode)	1	1	1	1	0
31	No Fault (Stand By)	1	1	1	1	1



### 1.3.4 Indoor unit diagnosis by MSMP and corrective actions

No.	Fault	Probable Cause	Corrective Action
1	Sensors failures of all types		Check sensors connections or replace sensors.
2	IPM Fault	Electronics HW problem	Check all wiring and jumper settings, if OK, replace electronics.
3	Bad EEPROM		No action, unless special parameters are required for unit operation.
4	DC under/over Voltage	Electronics HW problem	Check outdoor unit power supply voltage
5	AC under Voltage		Check outdoor unit power supply voltage
6	Indoor / Outdoor unit Communication mismatch	Indoor and Outdoor controllers are with different versions	Replace Indoor controller
7	No Communication	Communication or grounding wiring is not good.	Check Indoor to Outdoor wiring and grounding
8	Compressor Lock		Switch unit to STBY and restart
9	Bad Communication	Communication quality is low reliability	Check Indoor to Outdoor wiring and grounding

### 1.4 Judgment by MegaTool

MegaTool is a special tool to monitor the system states.

Using MegaTool requires:

- A computer with RS232C port.
- A connection wire for MegaTool.
- A special MegaTool software.

Use MegaTool according to following procedure:

- Setup MegaTool software: copy the software to the computer.
- Connect RS232C port in computer with MegaTool port in Indoor/Outdoor unit controller by the connection wire.
- Run the software and choose the COM port, you can monitor the A/C system state in monitor tab.

### 1.5 Simple procedures for checking the Main Parts

#### 1.5.1 Checking Mains Voltage.

Confirm that the Mains voltage is between 198 and 264 VAC. If Mains voltage is out of this range, abnormal operation of the system is expected. If in range check the Power (Circuit) Breaker and look for broken or loosed cable lugs or wiring mistake(s).

#### 1.5.2 Checking Power Input.

If Indoor unit power LED is unlighted, power down the system and check the fuse of the Indoor unit. If the fuse is OK replace the Indoor unit controller. If the fuse has blown, replace the fuse and power up again. Checking Power Input procedure for the Outdoor unit is the same as with the Indoor unit.

### 1.5.3 Checking the PCB.

Appearance inspect: Check discoloration, nick and connection of copper foil, short-circuit and open circuit, component soldering, bulgy and distortion of electrolytic capacitor.

Power circuit check: check voltage of every power level (5V, 12V, 15V) printed on back of PCB.

### 1.5.4 Checking the Outdoor Fan Motor.

Enter Test Mode (where the OFAN speed is high)

Check the voltage between lead wires according to the normal value as following:

- Between red wire and black wire: 310VDC +/- 20V
- Between orange wire and black wire: 15VDC +/- 1V
- Between yellow wire and black wire: 2-6VDC

### 1.5.5 Checking the Compressor.

The compressor is brushless permanance magnetic DC motor. Three coil resistances are THE same. Check the resistance between three poles.

### 1.5.6 Checking the Reverse Valve (RV).

Running in heating mode, check the voltage between two pins of reverse valve connector, normal voltage is 220VAC.

### 1.5.7 Checking the electrical expansion valve (EEV).

The EEV has two parts, drive part and valve. The drive part is a step motor; it is ringed on the valve. Check the drive voltage (12VDC). When Outdoor unit is power on, EEV shall run and have click and vibration.

## 1.6 Precaution, Advise and Notice Items

### 1.6.1 High voltage in Outdoor unit controller.

Whole controller, including the wires, connected to the Outdoor unit controller may have the potential hazard voltage when power is on. Touching the Outdoor unit controller may cause an electrical shock.

**Advise:** Don't touch the naked lead wire and don't insert finger, conductor or anything else into the controller when power is on.

### 1.6.2 Charged Capacitors

Three large-capacity electrolytic capacitors are used in the Outdoor unit controller. Therefore, charging voltage (380VDC) remains after power down. Discharging takes about three minutes after turned off. Touching the Outdoor unit controller before discharging may cause an electrical shock. When open the Outdoor unit controller cover, don't touch the soldering pin by hand or by any conductive material.

**Advise:** 1. Open the Outdoor unit controller cover only after five minutes from power down.  
2. Measure the electrolytic capacitors voltage before farther checking controller for safety.

### 1.6.3 Additional advises

When disassemble the controller or the front panel, turn off the power supply.

When connecting or disconnecting the connectors on the PCB, hold the whole housing, don't pull the wire.

There are sharp fringes and sting on shell. Use gloves when disassemble the A/C units.

**13. EXPLODED VIEWS AND SPARE PARTS LISTS**

**13.1 Outdoor Unit: DUO 38 DCI**

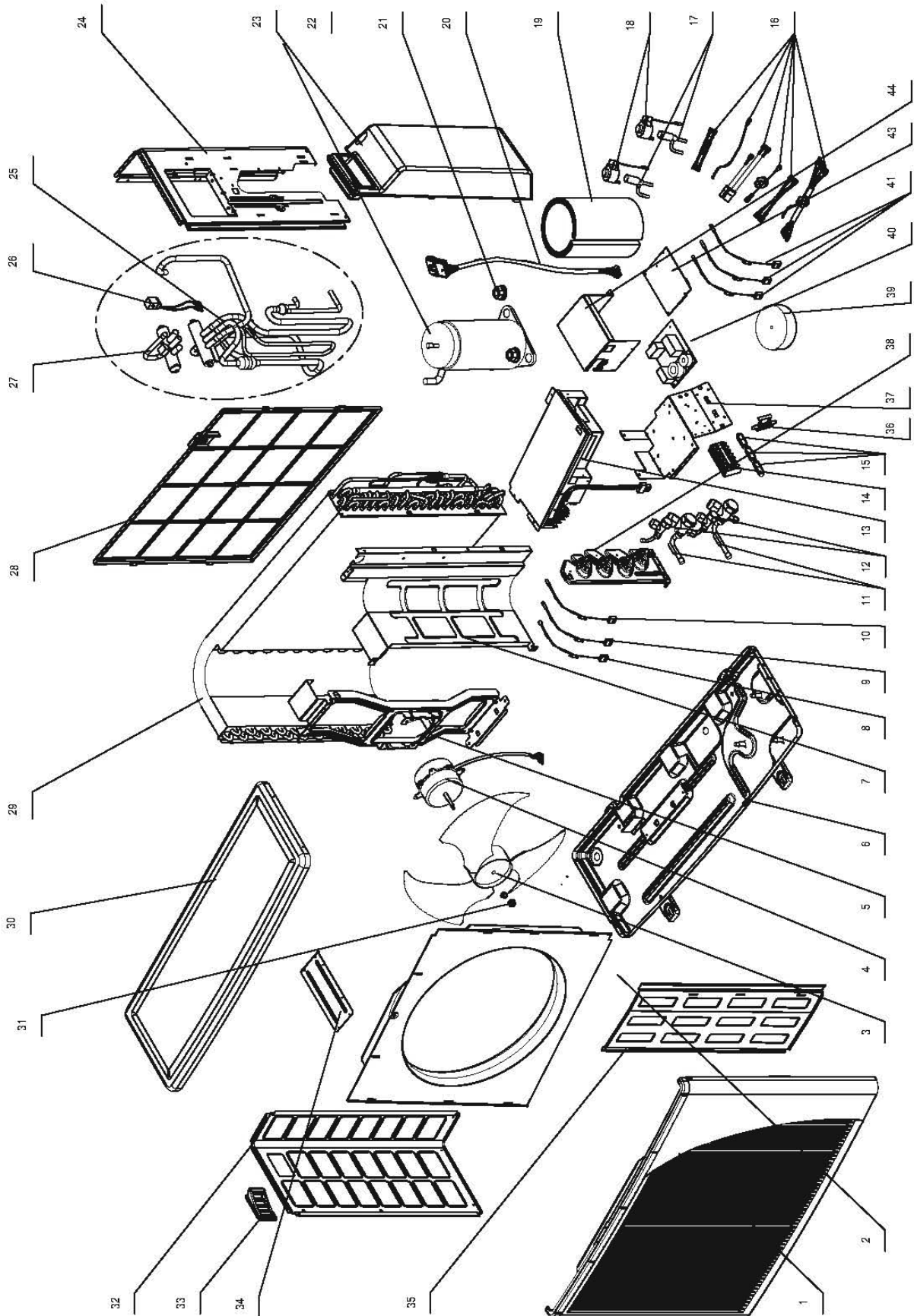

**13.2 Outdoor Unit: DUO 38 DCI**

No.	Part No.	Description	Quantity
1	433218	Front Panel A	1
2	4526340	Air inlet ring-420	1
3	4526476	Axial fan OD=401	1
4	452889600R	Resin Motor	1
5	433215	Motor Support	1
6	464600021	Base Painting Assy.	1
7	4526299	Partition	1
8	467400026	Outdoor air thermistor(OAT)	1
9	467400055	Compressor top thermistor(CTT)	1
10	467400056	Outdoor coil thermistor(OCT)	1
11	452630201	3/8" Gas Valve(R410A)	1
	452630200	3/8" Gas Valve(R410A)	1
12	461000004	1/4" Liquid Valve(R410A)	2
13	467300025R	OUTDOOR DC INVERTER CONTROLLER	1
14	4527130	terminal block	1
15	204107	Cable clip Nylon	3
16	4526226	Power lead wire	1
	4526968	Grounding wire with magnetic ring	1
	452926600R	Power Cord Wire	2
17	4526827	Electronical expansion valve	2
18	452682802	EEV coil CAM-MD12FKS-2 White connector, 530mm)	1
	452682800	EEV coil CAM-MD12FKS-1 (Red, 530mm)	1
19	4526344	Comp. Insulation1	1
20	4526221	Compressor wire	1
21	4510677	Nut With Flange M8	3
22	4526204	Compressor Assy	1
23	465340083	Valve Cover	1
24	4526429	Right side panel (painting plate)	1
25	461600010	4way valve soldering assy	1
26	4522509	4-Way valve coil	1
27	4518952	4-W valve SHF-4H for R410A	1
28	433228	Back Side Net	1
29	462000000	condensor Soldering assy	1
30	4519614	Painting Top Cover	1
31	4519300	Nut M5 L	1
32	4519607	Left Side Panel Painting Plate	1
33	433225	Handle	1
34	4526298	Bridge	1
35	464860054	Painting Insulation Plate	1
36	4526219	Fuse 6C(15A,230V)EHK:150-007-00	1
37	452823600	Therminal sheet	1
38	4526430	Valve Support(painting plate)	1
39	4526396	Choke assy. 167-021-01	1
40	467300024R	EMI filter board	1
41	467400060	Suction Temperature Sensor(SUCT)	1
	467400061	Suction Temperature Sensor(SUCT)	1
43	4526227R	MSMP communcation board 906-002-00	1
44	452823600	Terminal Plate Assy.	1

# APPENDIX A

## INSTALLATION AND OPERATION MANUAL

- ▶ **INSTALLATION MANUAL DUO 38 DCI**