

Pioneer

Service Manual

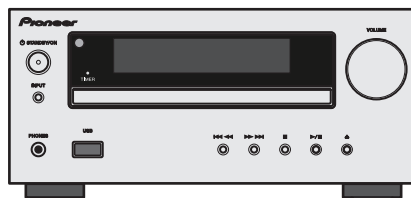

X-HM20-K

ORDER NO.
RRV4220

CD Receiver System

X-HM20-K

X-HM20-S

X-HM10-K

X-HM10-S

THIS MANUAL IS APPLICABLE TO THE FOLLOWING MODEL(S) AND TYPE(S).

Model	Type	Power Requirement	Serial No.	Remarks
X-HM20-K	SYXJC8	AC 220 V to 240 V	&&&&#####YY	YY: Europe
X-HM20-S	SYXJC8	AC 220 V to 240 V	&&&&#####YY	YY: Europe
X-HM10-K	SYXJC8	AC 220 V to 240 V	&&&&#####YY	YY: Europe
X-HM10-S	SYXJC8	AC 220 V to 240 V	&&&&#####YY	YY: Europe



PIONEER CORPORATION 1-1, Shin-ogura, Saiwai-ku, Kawasaki-shi, Kanagawa 212-0031, Japan

PIONEER ELECTRONICS (USA) INC. P.O. Box 1760, Long Beach, CA 90801-1760, U.S.A.

PIONEER EUROPE NV Haven 1087, Keetberglaan 1, 9120 Melsele, Belgium

PIONEER ELECTRONICS ASIACENTRE PTE. LTD. 253 Alexandra Road, #04-01, Singapore 159936

©PIONEER CORPORATION 2011

K-IZV SEPT. 2011 Printed in Japan

SAFETY INFORMATION



This service manual is intended for qualified service technicians; it is not meant for the casual do-it-yourselfer. Qualified technicians have the necessary test equipment and tools, and have been trained to properly and safely repair complex products such as those covered by this manual.

Improperly performed repairs can adversely affect the safety and reliability of the product and may void the warranty. If you are not qualified to perform the repair of this product properly and safely, you should not risk trying to do so and refer the repair to a qualified service technician.

WARNING

This product may contain a chemical known to the State of California to cause cancer, or birth defects or other reproductive harm.

Health & Safety Code Section 25249.6 - Proposition 65

IMPORTANT

THIS PIONEER APPARATUS CONTAINS LASER OF CLASS 1. SERVICING OPERATION OF THE APPARATUS SHOULD BE DONE BY A SPECIALLY INSTRUCTED PERSON.

Laser Pickup specifications and Laser characteristics

For CD	Wave length (typ) : 790 nm
	Operation output : 4 mW CW, Class 1
	Maximum output : Class 1 (Under fault condition)

WARNING

The Laser component is capable of emitting radiation exceeding the limit for CLASS 1. A specially instructed person should do servicing operation of the apparatus.

LABEL CHECK

CAUTION

This product is a class 1 laser product classified under the Safety of laser products, IEC 60825-1:1993 + A1:1997 + A2:2001 but this product contains a laser diode higher than Class 1. To ensure continued safety, do not remove any covers or attempt to gain access to the inside of the product. Refer all servicing to qualified personnel.

The following caution label appears on your unit.

Location: Inside of the unit

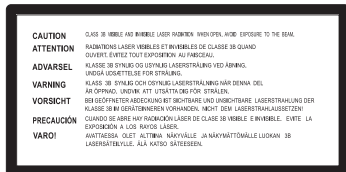

DSB-S-2-2b*_B1_En

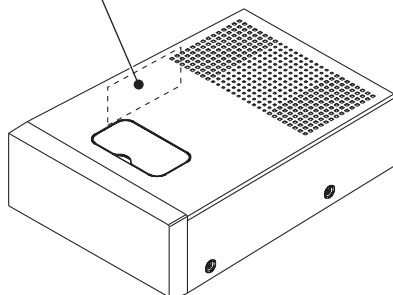

CONTENTS

SAFETY INFORMATION.....	2	
1. SERVICE PRECAUTIONS.....	4	
1.1 NOTES ON SOLDERING.....	4	A
1.2 WHEN REPLACING CD MECHA UNIT.....	4	
2. SPECIFICATIONS.....	5	
3. BASIC ITEMS FOR SERVICE.....	6	
3.1 PCB LOCATIONS.....	6	
3.2 JIGS LIST.....	7	
4. BLOCK DIAGRAM.....	8	
4.1 OVERALL WIRING DIAGRAM.....	8	
4.2 OVERALL BLOCK DIAGRAM.....	10	
5. DIAGNOSIS.....	11	
5.1 TROUBLESHOOTING.....	11	
5.2 PROTECTION CIRCUIT.....	12	
6. SERVICE MODE.....	12	B
7. DISASSEMBLY.....	13	
8. EACH SETTING AND ADJUSTMENT.....	19	
8.1 UPDATING OF THE FIRMWARE.....	19	
9. EXPLODED VIEWS AND PARTS LIST.....	20	
9.1 PACKING SECTION.....	20	
9.2 EXTERIOR SECTION.....	22	
10. SCHEMATIC DIAGRAM.....	24	
10.1 MAIN PCB ASSY (1/7).....	24	
10.2 MAIN PCB ASSY (2/7).....	26	
10.3 MAIN PCB ASSY (3/7).....	28	
10.4 MAIN PCB ASSY (4/7).....	30	
10.5 MAIN PCB ASSY (5/7).....	32	C
10.6 MAIN PCB ASSY (6/7).....	34	
10.7 MAIN PCB ASSY (7/7).....	36	
10.8 IPOD PCB ASSY (X-HM20 ONLY).....	38	
10.9 RADIO PCB ASSY.....	40	
10.10 DISPLAY PCB ASSY.....	42	
10.11 KEY-SWITCH PCB ASSY.....	44	
10.12 HEADPHONE PCB ASSY.....	45	
10.13 POWER PCB ASSY.....	46	
10.14 USB PCB ASSY.....	48	
11. PCB CONNECTION DIAGRAM.....	50	
11.1 MAIN and IPOD PCB ASSYS.....	50	D
11.2 DISPLAY and KEY-SWITCH PCB ASSYS.....	54	
11.3 RADIO PCB ASSY.....	56	
11.4 HEADPHONE and USB PCB ASSYS.....	57	
11.5 POWER PCB ASSY.....	58	

1. SERVICE PRECAUTIONS

1.1 NOTES ON SOLDERING

- For environmental protection, lead-free solder is used on the printed circuit boards mounted in this unit.
Be sure to use lead-free solder and a soldering iron that can meet specifications for use with lead-free solders for repairs accompanied by reworking of soldering.
- Compared with conventional eutectic solders, lead-free solders have higher melting points, by approximately 40 °C. Therefore, for lead-free soldering, the tip temperature of a soldering iron must be set to around 373 °C in general, although the temperature depends on the heat capacity of the PC board on which reworking is required and the weight of the tip of the soldering iron.

Do NOT use a soldering iron whose tip temperature cannot be controlled.

- Compared with eutectic solders, lead-free solders have higher bond strengths but slower wetting times and higher melting temperatures (hard to melt/easy to harden).

The following lead-free solders are available as service parts:

- Parts numbers of lead-free solder:
 - GYP1006 1.0 in dia.
 - GYP1007 0.6 in dia.
 - GYP1008 0.3 in dia.

1.2 WHEN REPLACING CD MECHA UNIT

It is necessary to remove the soldering on the short circuit point after connecting the flexible cable.

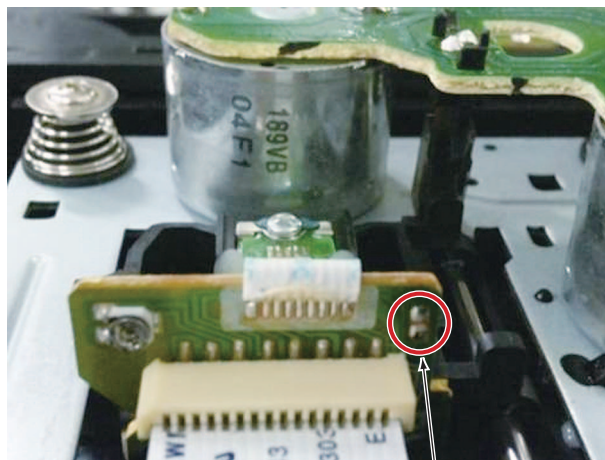

Short circuit point

5 6 7 8

2. SPECIFICATIONS

As part of our policy of continuous improvement, PIONEER reserves the right to make design and specification changes for product improvement without prior notice. The performance specification figures indicated are nominal values of production units. There may be some deviations from these values in individual units.

General

Power source	AC 220 V to 240 V, 50 Hz/60 Hz
Power consumption	Power on: 45 W (X-HM20) 30 W (X-HM10) Power stand-by: 0.4 W
Dimensions	Width: 215 mm Height: 99 mm Depth: 300 mm
Weight	3.8 kg (X-HM20) 3.7 kg (X-HM10)

Amplifier

Output power	RMS: 15 W + 15 W (1 kHz, 10 % T.H.D., 4 ohms)
Output terminals	Speakers: 4 ohms 20 Hz to 20 kHz Video output (X-HM20 only): 1 Vp-p Headphones: 16 ohms (recommended: 32 ohms)
Input terminals	Line in (Analog input): 500 mV/47 k ohms

CD player

Type	Single disc multi-play compact disc player
Signal readout	Non-contact, 3-beam semiconductor laser pickup
D/A converter	Multi bit D/A converter
Frequency response	20 Hz to 20 000 Hz
Dynamic range	90 dB (1 kHz)

USB

USB host interface	<ul style="list-style-type: none"> Complies with USB 1.1 (Full Speed)/2.0 Mass Storage Class. Support Bulk only and CBI protocol.
Support file	<ul style="list-style-type: none"> MPEG 1 Layer 3 WMA (Non DRM)
Bitrate support	<ul style="list-style-type: none"> MP3 (32 kbps to 320 kbps) WMA (64 kbps to 160 kbps)
Other	<ul style="list-style-type: none"> Maximum total number of MP3/WMA files is 999. Maximum total number of folders is 99 INCLUSIVE of root directory. The ID3TAG information supported are TITLE, ARTIST and ALBUM only. Supports ID3TAG version 1 and version 2.
File system support	<ul style="list-style-type: none"> Support USB devices with Microsoft Windows/DOS/FAT 12/FAT 16/ FAT 32. 2 kbyte block length for sector.

Tuner



Frequency range	FM: 87.5 MHz to 108 MHz AM: 522 kHz to 1,620 kHz
Preset	40 (FM and AM station)

Speaker

X-HM20	
Type	2-way type speaker system 5 cm Tweeter 10 cm Woofer
Maximum input power	15 W
Impedance	4 ohms
Dimensions	Width: 132 mm Height: 260 mm Depth: 173 mm
Weight	2.0 kg/each

X-HM10	
Type	2-way type speaker system Piezoelectric Tweeter 10 cm Woofer
Maximum input power	15 W
Impedance	4 ohms
Dimensions	Width: 132 mm Height: 260 mm Depth: 158 mm
Weight	1.6 kg/each

Accessories

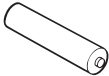
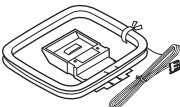
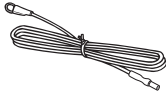
 <p>iPhone adapters x3 (X-HM20 only) (92L43200033101) (92L43200033201) (92L43200033301)</p>	 <p>Remote control (92L34900101001)</p>	 <p>"AA" size battery</p>	 <p>AM loop aerial (92L50100680101)</p>	 <p>FM aerial (92L28101510501)</p>	<p>Power Cord (92L20018200101)</p> <p>Warranty card</p> <p>Operation instructions (92L87500200101)</p>
--	--	--	---	---	--

X-HM20-K

5 6 7 8

3. BASIC ITEMS FOR SERVICE

3.1 PCB LOCATIONS

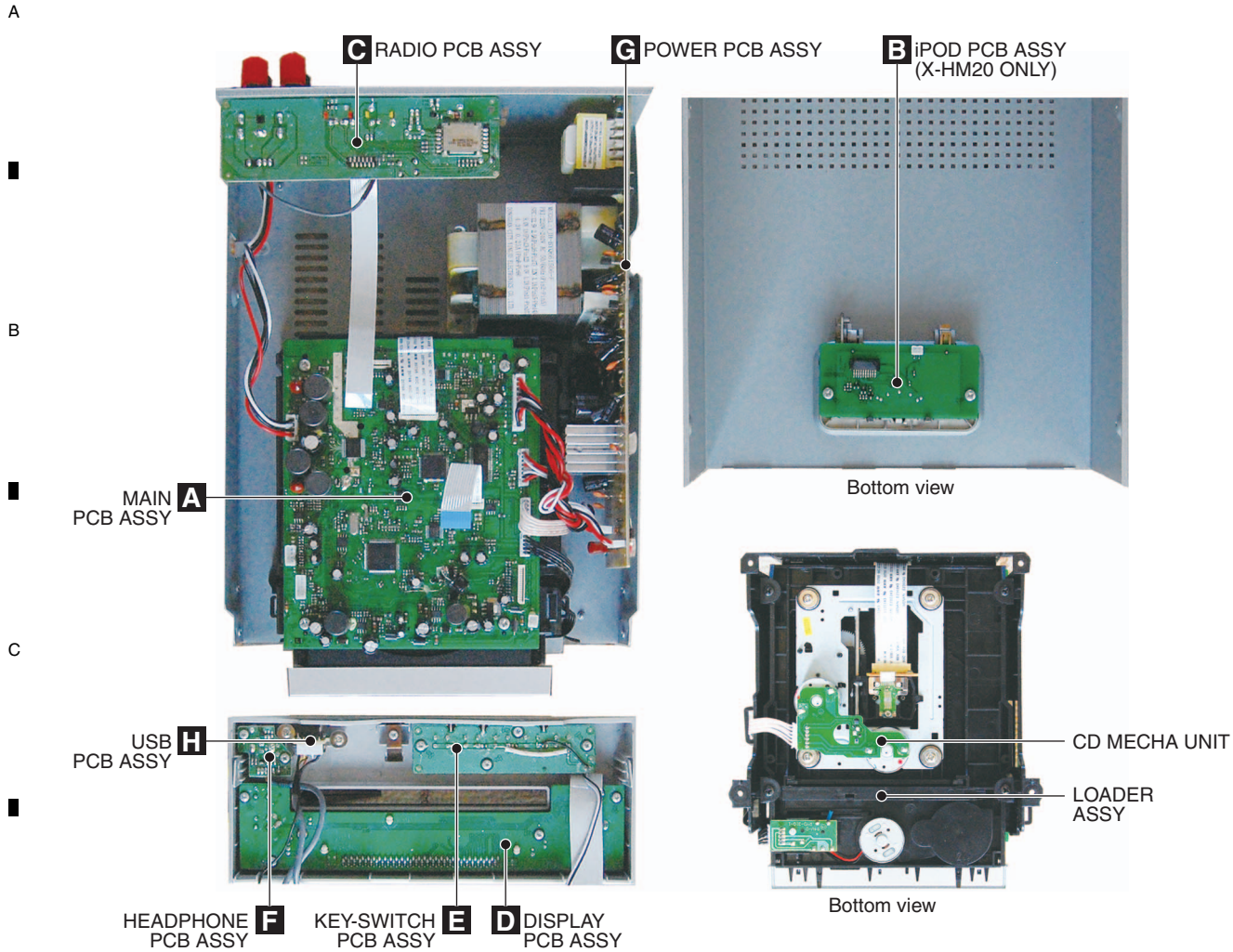

NOTES:

- Parts marked by “NSP” are generally unavailable because they are not in our Master Spare Parts List.
- The ⚠ mark found on some component parts indicates the importance of the safety factor of the part. Therefore, when replacing, be sure to use parts of identical designation.

Mark No.	Description	Part No.	Mark No.	Description	Part No.
LIST OF ASSEMBLIES					
	1..MAIN PCB ASSY (X-HM20)	92L36100201011		1..IPOD PCB ASSY (X-HM20 ONLY)	92L36600201010
	1..MAIN PCB ASSY (X-HM10)	92L36100101011		1..KEY-SWITCH PCB ASSY (X-HM20)	92L37200201010
⚠	1..POWER PCB ASSY (X-HM20)	92L36800201010		1..KEY-SWITCH PCB ASSY (X-HM10)	92L37200101011
⚠	1..POWER PCB ASSY (X-HM10)	92L36800101010			
	1..DISPLAY PCB ASSY (X-HM20)	92L36500201010		1..CD MECHA UNIT	92L28700220301
	1..DISPLAY PCB ASSY (X-HM10)	92L36500101010		1..LOADER ASSY	92L5150020071T
	1..RADIO PCB ASSY (X-HM20)	92L36400201010			
	1..RADIO PCB ASSY (X-HM10)	92L36400101010			
	1..HEADPHONE PCB ASSY (X-HM20)	92L37100201011			
	1..HEADPHONE PCB ASSY (X-HM10)	92L37100101011			
	1..USB PCB ASSY (X-HM20)	92L36900201011			
	1..USB PCB ASSY (X-HM10)	92L36900101011			

4. BLOCK DIAGRAM

4.1 OVERALL WIRING DIAGRAM

C
RADIO PCB ASSY
 (X-HM20: 92L36400201010)
 (X-HM10: 92L36400101010)

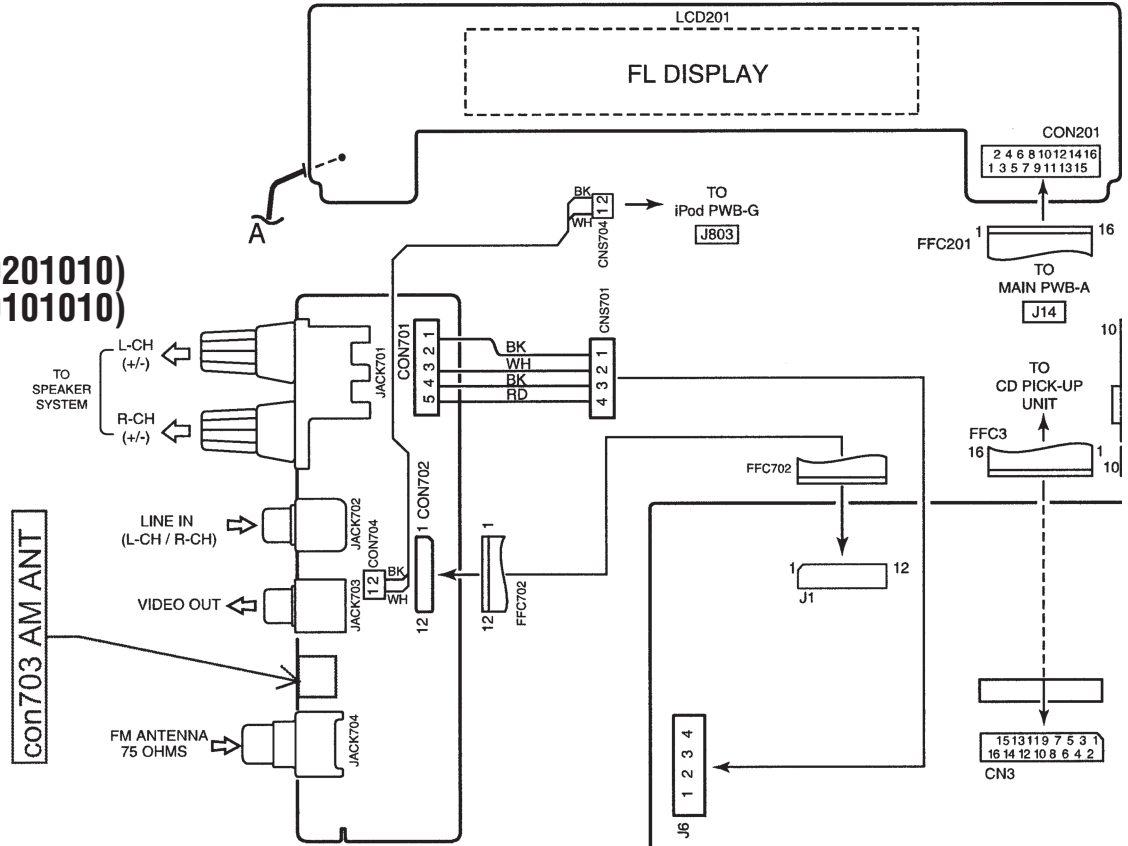

F
HEADPHONE PCB ASSY
 (X-HM20: 92L37100201011)
 (X-HM10: 92L37100101011)

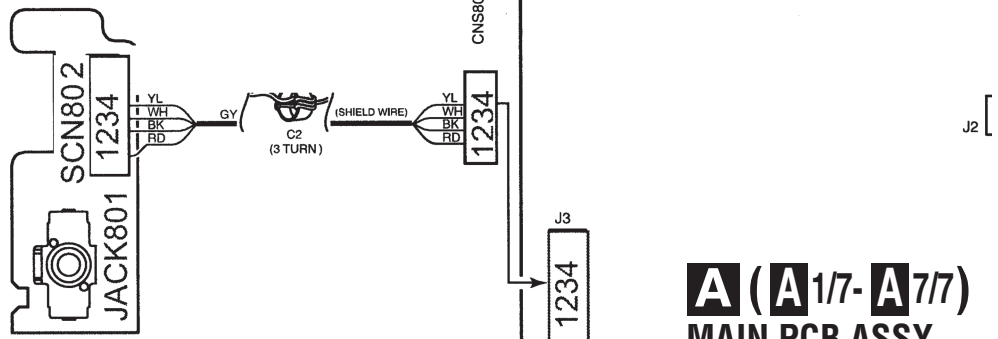

H
USB PCB ASSY
 (X-HM20: 92L36900201011)
 (X-HM10: 92L36900101011)

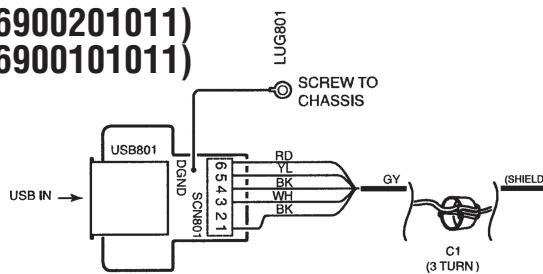

A (A1/7 - A7/7)
MAIN PCB ASSY
 (X-HM20: 92L36100)
 (X-HM10: 92L36100)

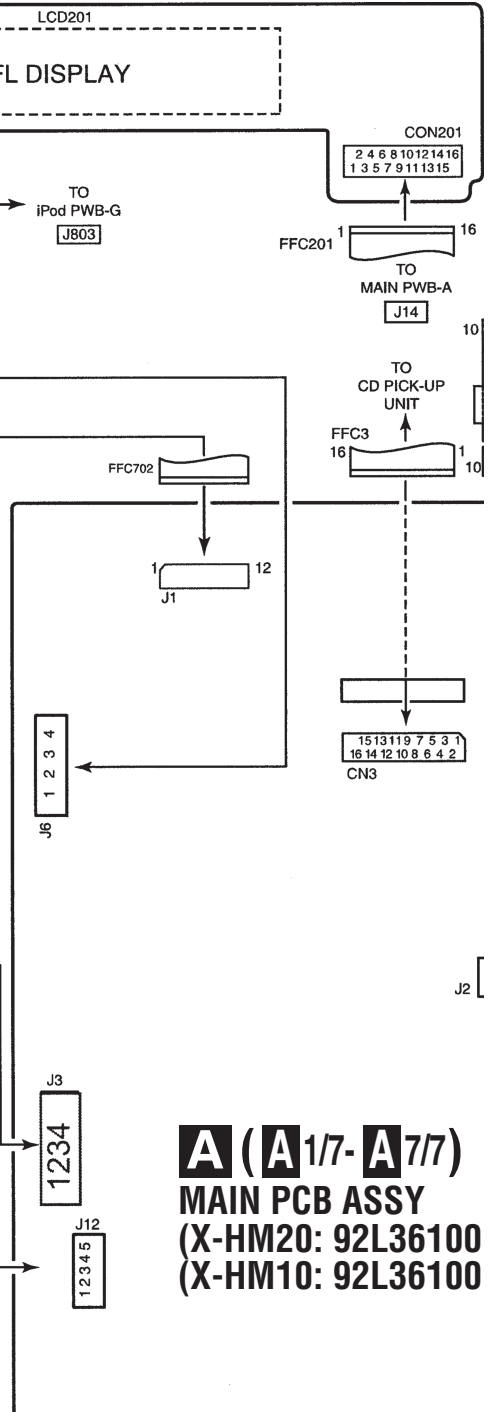

- When ordering service parts, be sure to refer to "EXPLODED VIEWS and PARTS LIST" or "PCB PARTS LIST".
- The ⚠ mark found on some component parts indicates the importance of the safety factor of the part. Therefore, when replacing, be sure to use parts of identical designation.
-  : The power supply is shown with the marked box.

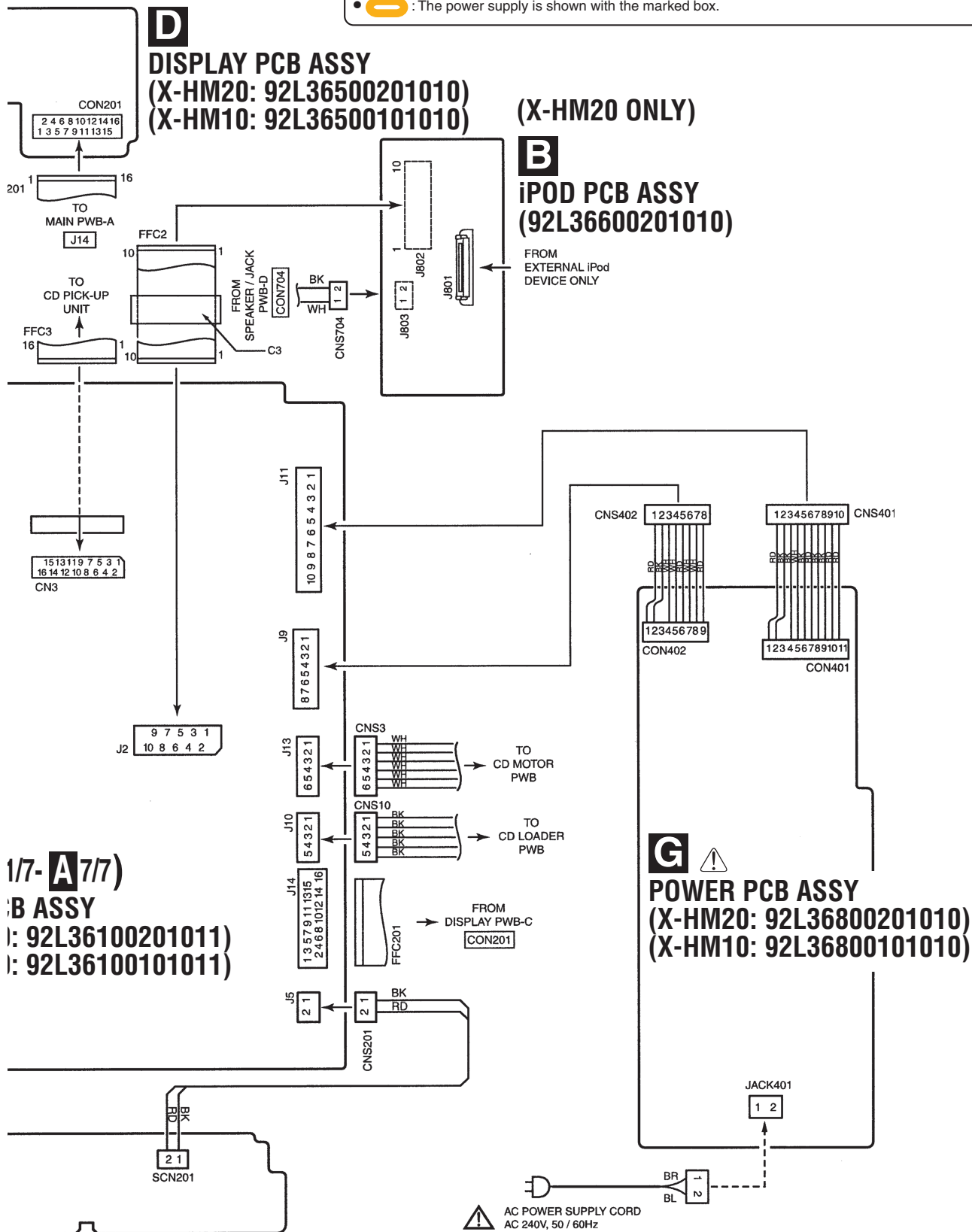

1/7- **A** 7/7)
B ASSY
 (X-HM20: 92L36100201011)
 (X-HM10: 92L36100101011)

4.2 OVERALL BLOCK DIAGRAM

A
B
C
D
E
F

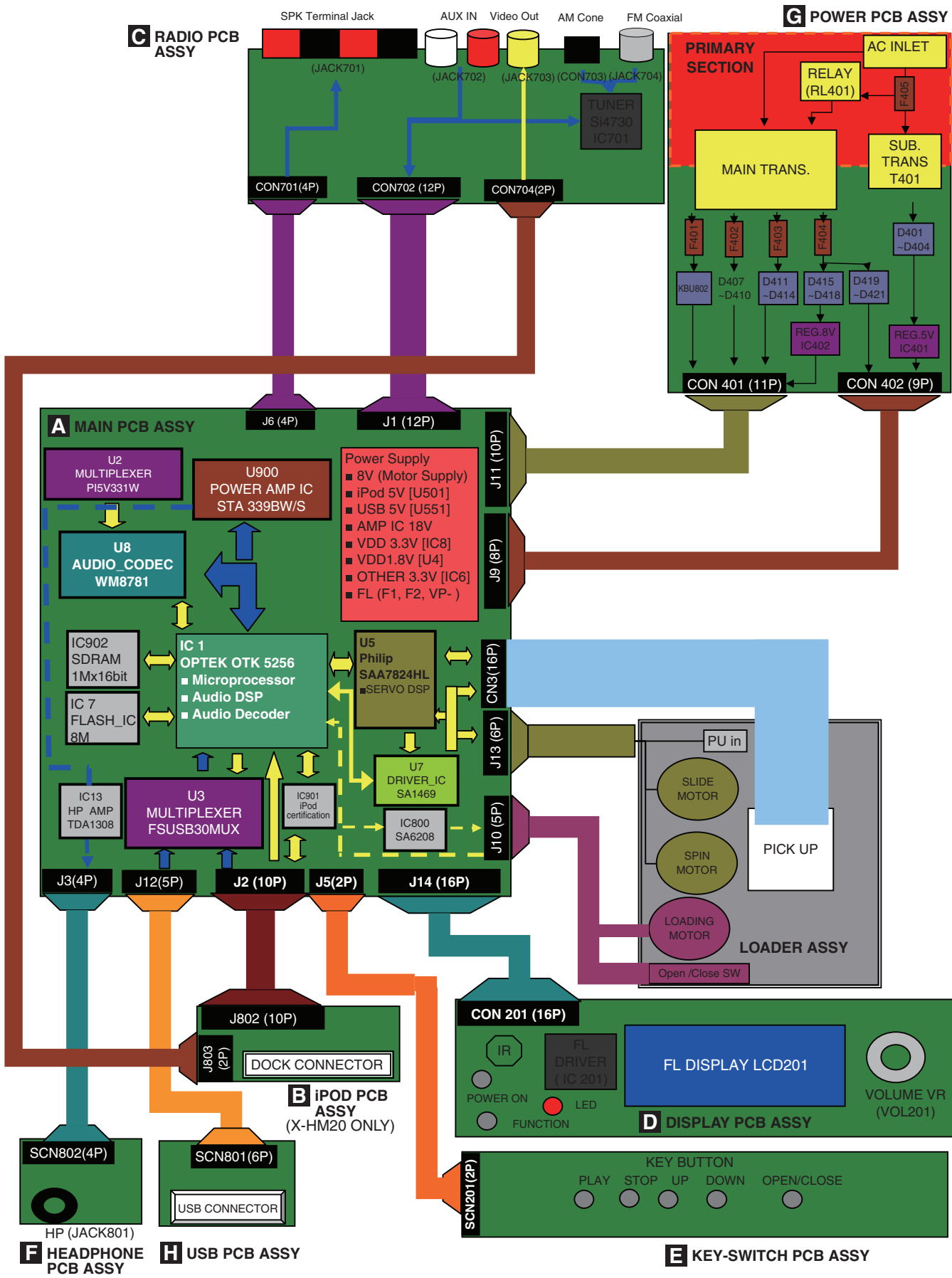

5. DIAGNOSIS

5.1 TROUBLESHOOTING

No Power

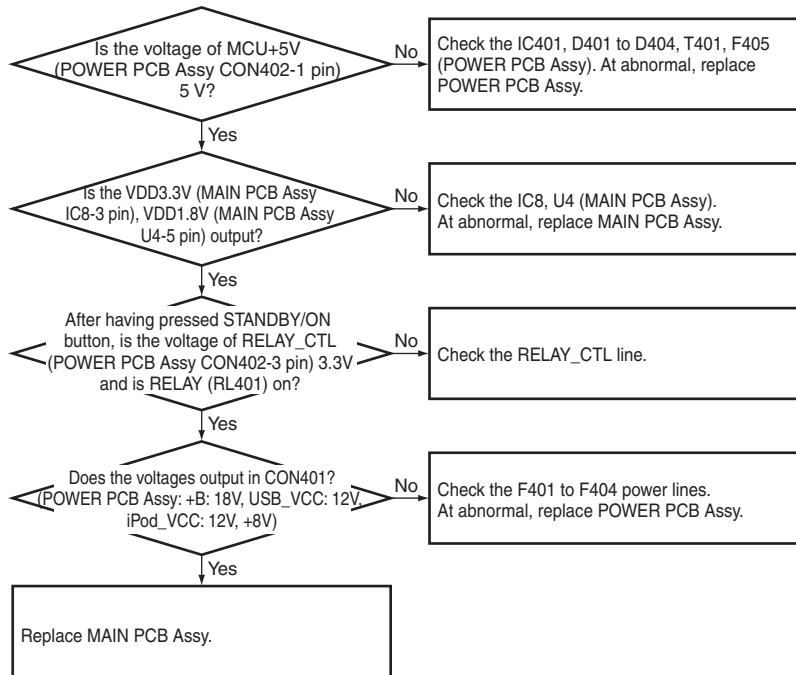

Although a CD is inserted and the Tray is closed, "NO DISC" is displayed.

Press the Tray CD Eject Button without inserting a disc, and try starting the playback operation.

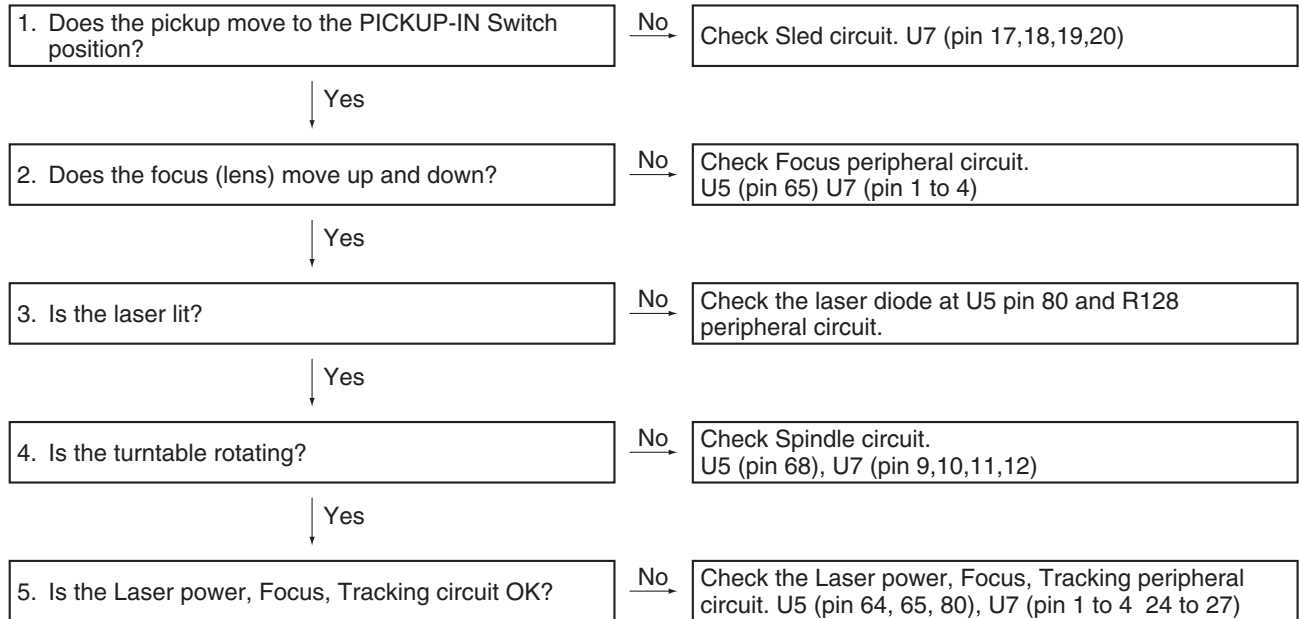

5.2 PROTECTION CIRCUIT

The protection circuit is activated when a failure in power or voltage is generated in the D-AMP circuit. If the protection circuit is activated, the unit will shut itself off and the TIMER indicator on the front panel will start flashing. The indicator will continue to flash until the problem is resolved. After a shutdown, to turn the unit back on, unplug the AC power cord then plug it back into the AC outlet.

A

B

6. SERVICE MODE

There is no information to be shown in this chapter.

C

D

E

F

7. DISASSEMBLY

Note:

- (1) Do NOT look directly into the pickup lens. The laser beam may cause eye injury.
- (2) Even if the unit shown in the photos and illustrations in this manual may differ from your product, the procedures described here are common.

[1] Top Cabinet

- (1) Remove the four screws.
- (2) Remove the four screws.

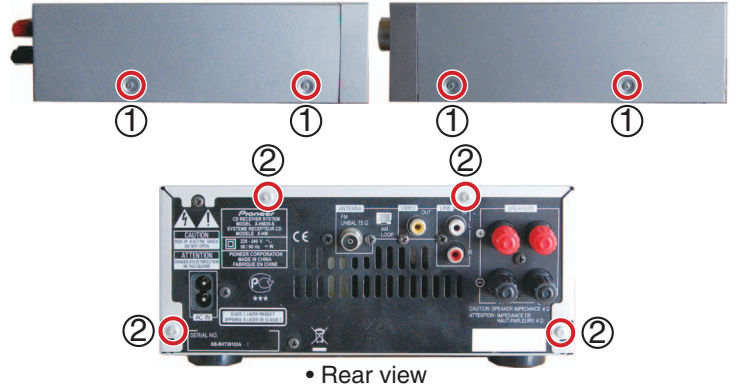

- (3) Remove the top cabinet.

Note (X-HM20 only):

Please do not damage the cables when removing the top cabinet.



[2] iPod PCB Assy (X-HM20 only)

- (1) Remove the top cabinet.
(See procedure "[1] Top Cabinet".)

- (1) Disconnect the one flexible cable and one connectors. (J802, J803)
- (2) Remove the two screws.
- (3) Remove the iPod PCB Assy.

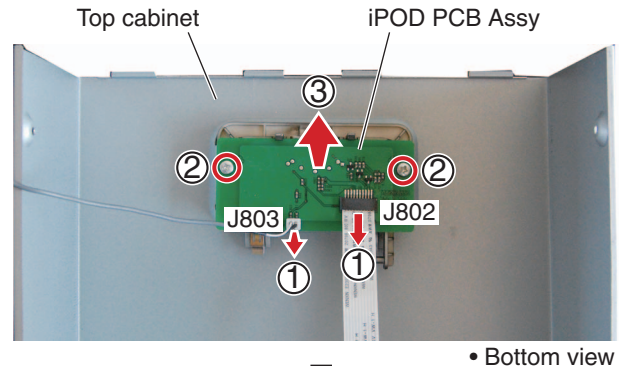

A [3] Front Panel Section

- (1) Remove the top cabinet.
(See procedure "[1] Top Cabinet".)

- (1) Remove the two screws.
- (2) Remove the two screws.
- (3) Unhook the two hooks.



• Bottom view

- (4) Disconnect the one flexible cable and three connectors. (J3, J5, J12, J14)
- (5) Release the jumper wires from hook.
- (6) Remove the one screw.

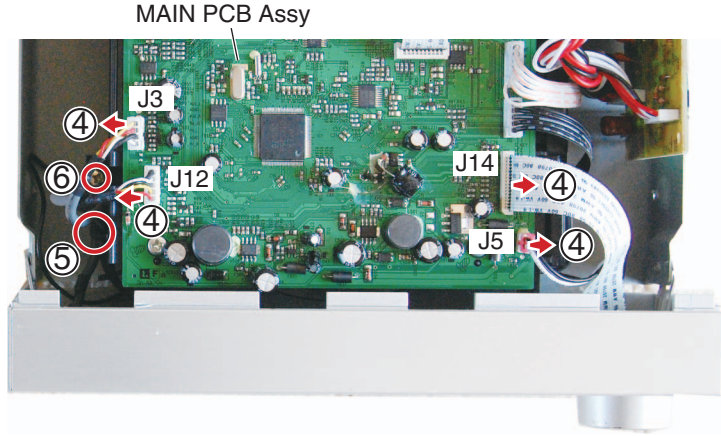

- (7) Remove the volume knob.
- (8) Remove the nut and washers.
- (9) Remove the front panel section.

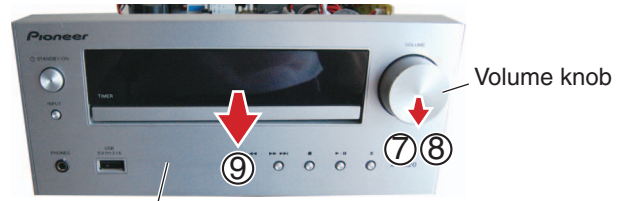

Front panel section

- (10) Remove the two screws.
- (11) Remove the 12 screws.
- (12) Remove the DISPLAY, KEY-SWITCH, HEADPHONE and USB PCB Assemblies.

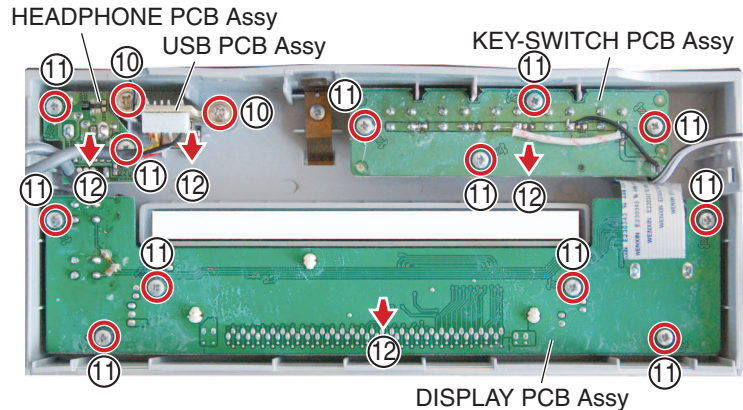

How to open the tray when the power cannot be on

- (1) Insert the thin minus screwdriver to the slit.
- (2) Slide the lever in the arrow direction.
- (3) Pull out the tray by hand.

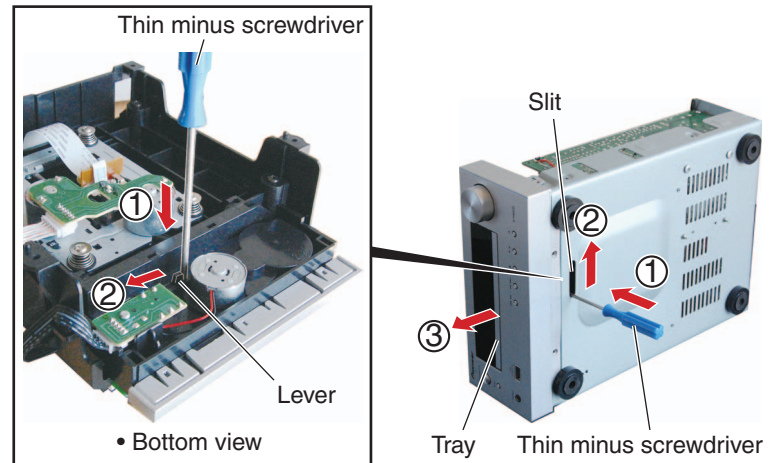

[4] RADIO PCB Assy

- (1) Remove the top cabinet.
(See procedure "[1] Top Cabinet".)

-
- (1) Remove the five screws.

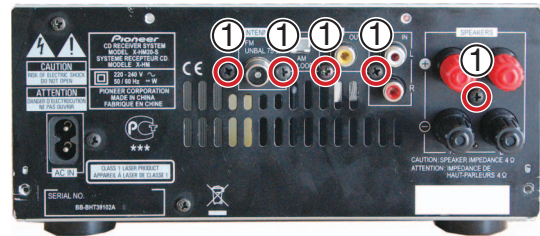

• Rear view



- (2) Disconnect the one flexible cable and one connectors. (J1, J6)
- (3) Remove the RADIO PCB Assy.

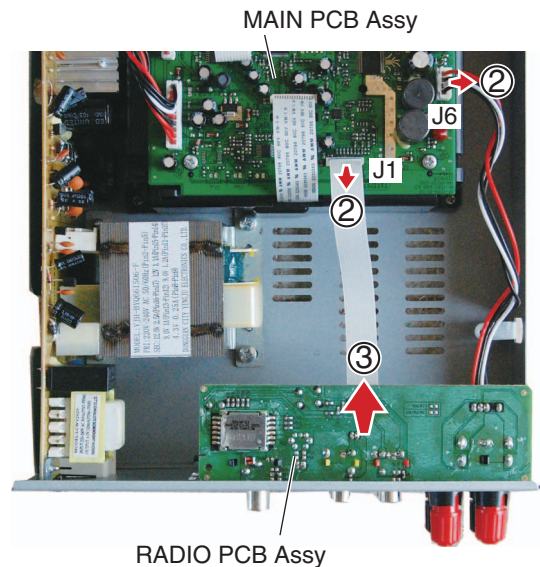

A [5] POWER PCB Assy

(1) Remove the top cabinet.
(See procedure "[1] Top Cabinet".)

(1) Remove the two screws.

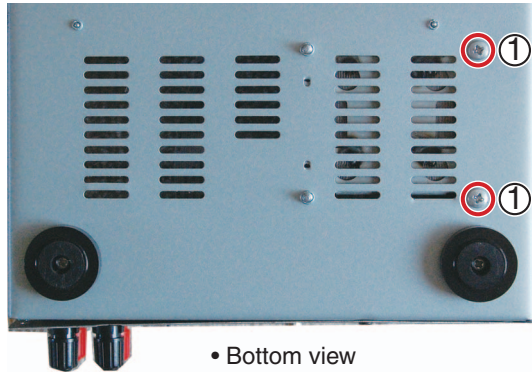

(2) Remove the one screw.

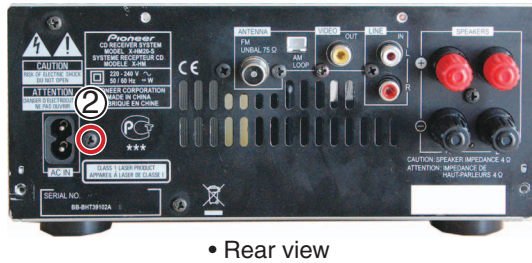

(3) Remove the three screws.

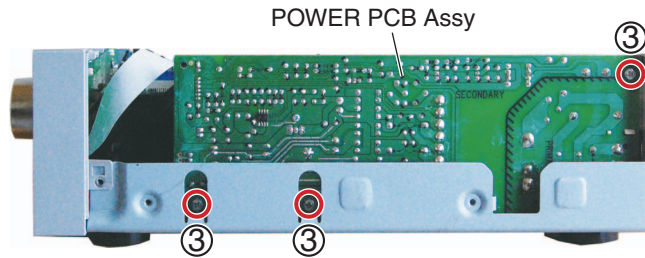

(4) Remove the two screws.
 (5) Disconnect the two connectors.
 (J9, J11)
 (6) Remove the POWER PCB Assy.

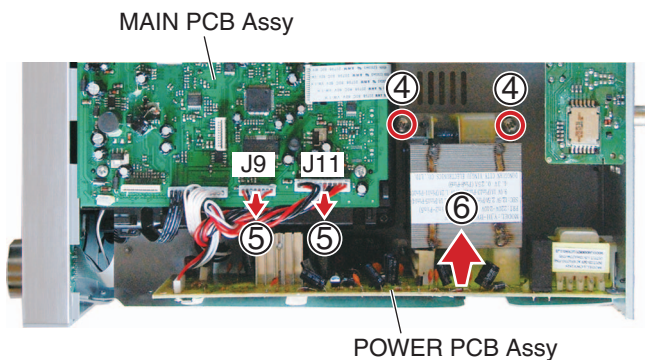

[6] MAIN PCB Assy, LOADER Assy, CD MECHA Unit

- (1) Remove the top cabinet.
(See procedure "[1] Top Cabinet".)
- (2) Remove the front panel section.
(See procedure "[3] Front Panel Section".)

-
- (1) Disconnect the two flexible cables and five connectors. (J1, J6, J9, J10, J11, J13, J19)
 - (2) Remove the four screws.
 - (3) Remove the MAIN PCB Assy.

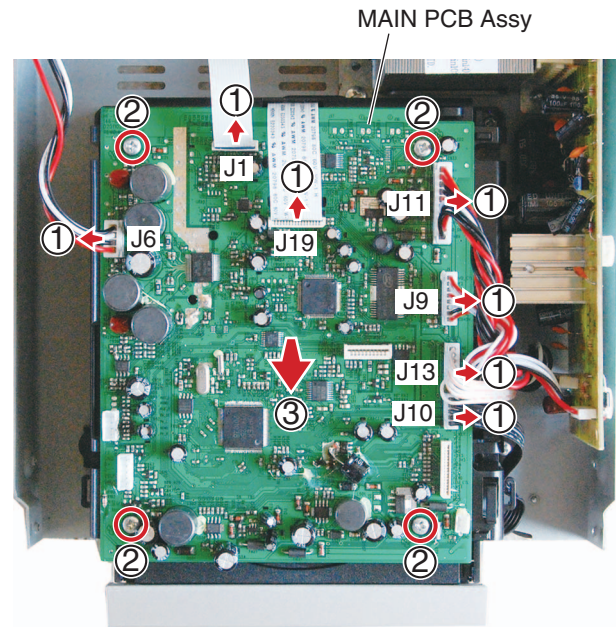

- (4) Remove the three screws.
- (5) Remove the LOADER Assy.

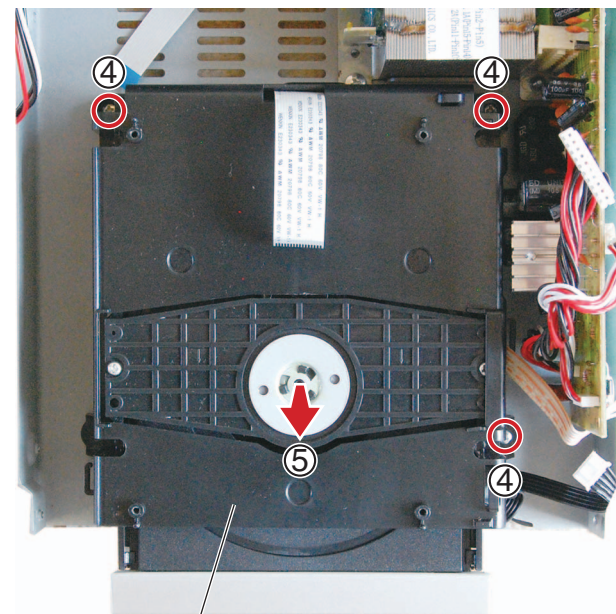

- A (6) Remove the four screws.
- (7) Remove the CD MECHA Unit.

Note:
Removal of the disc tray cover is not required during disassembly/reassembly of the front panel section, because this cover does not interfere with the front panel.

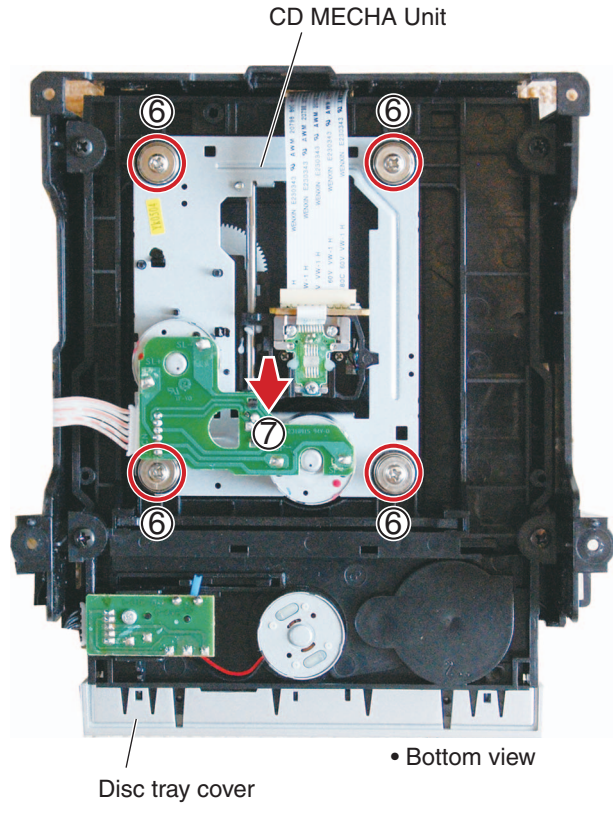

B

C

D

The Application Position of Adhesive

X-HM20 ONLY

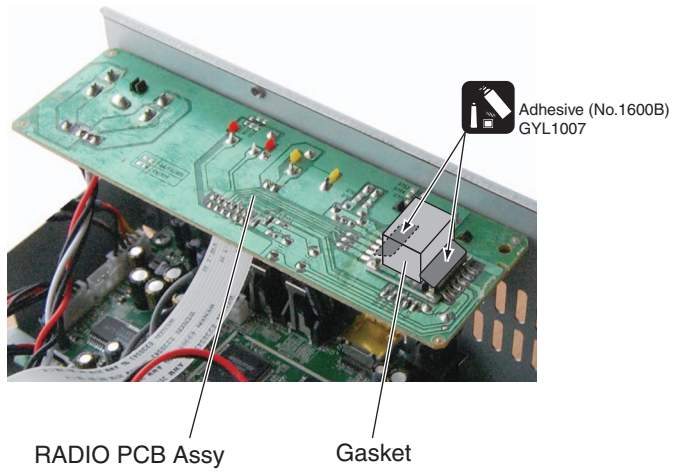
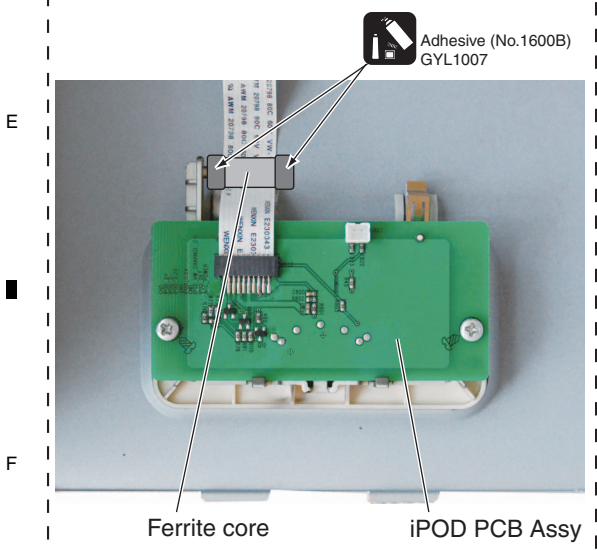

E

F

8. EACH SETTING AND ADJUSTMENT

8.1 UPDATING OF THE FIRMWARE

■ MCU software

1. Create a "system" folder in USB device.
Note: "system" folder must be written in lower-case letter.
2. Copy the upgrade file (upgrade_Pioneer_108P.bin) and the text file (upgrade.txt) into the "system" folder in USB device.
3. Turn on the main unit and select the USB function.
4. Connect the USB device.
5. FL will display "Upgrade" - indicating upgrading in process.

Caution: During upgrading process, DO NOT CUT THE AC SUPPLY.



6. FL will display "Success" - indicating the upgrading process is completed.



7. After FL display "Success", unplug the power cord from the main unit then only remove the USB device from main unit.
8. Re-plug in the power cord to the main unit and turn on the main unit.
The software upgrade is completed.

■ To check the software version

1. Press INPUT button to "Line in" function.
2. In "Line in" function,
short press ►►►► button once then long press ►/|| (PLAY/PAUSE) button until the software version is displayed.
software version display: X-HM20-K/-S → "CD-HM20R Vxxx", X-HM10-K/-S → "CD-HM10R Vxxx"



9. EXPLODED VIEWS AND PARTS LIST

- NOTES:
- Parts marked by "NSP" are generally unavailable because they are not in our Master Spare Parts List.
 - The \triangle mark found on some component parts indicates the importance of the safety factor of the part. Therefore, when replacing, be sure to use parts of identical designation.
 - Screws adjacent to ∇ mark on product are used for disassembly.
 - For the applying amount of lubricants or glue, follow the instructions in this manual. (In the case of no amount instructions, apply as you think it appropriate.)

9.1 PACKING SECTION

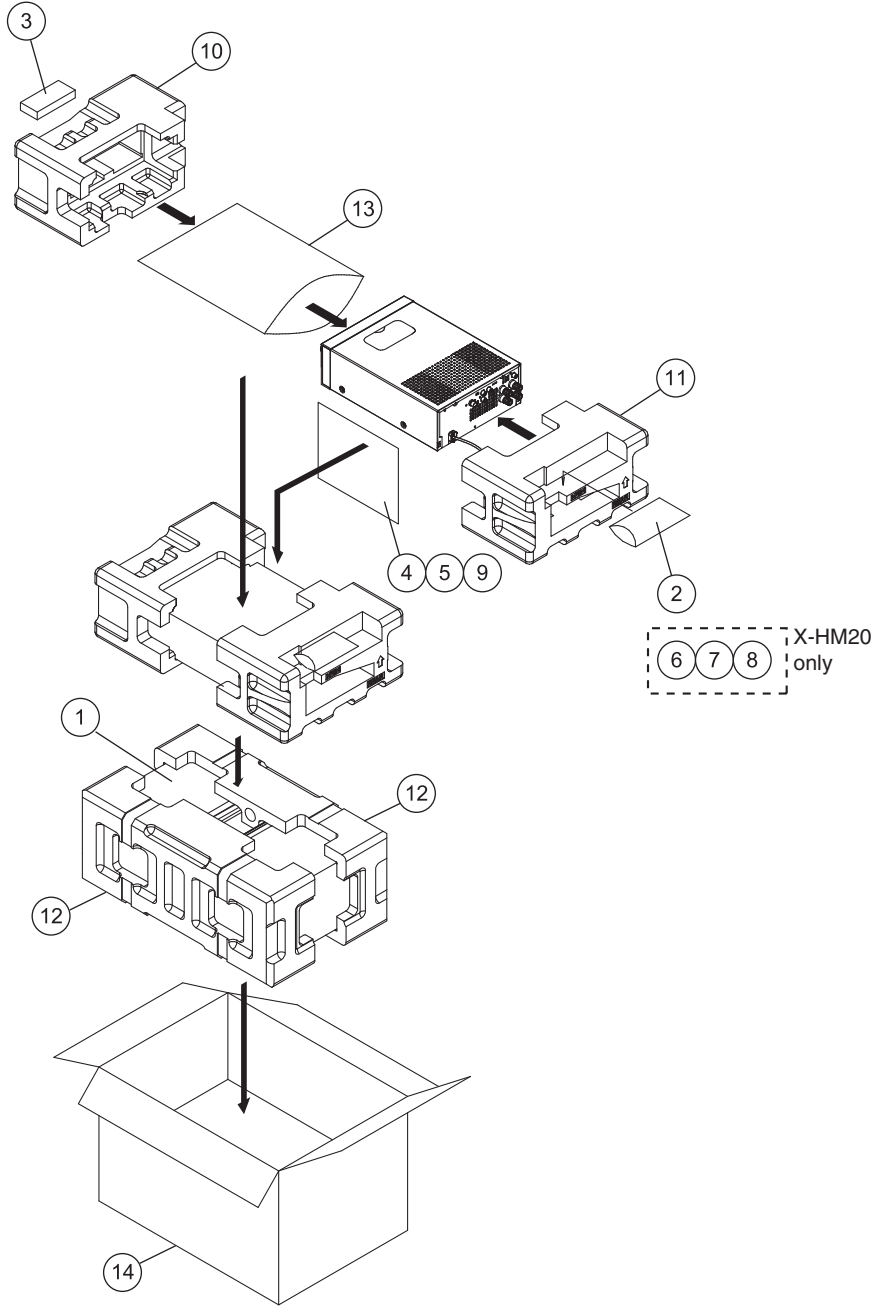

(1) PACKING SECTION PARTS LIST

Mark No.	Description	Part No.
	1 Speaker	See Contrast table (2)
⚠	2 Power Cord	92L20018200101
	3 Remote Control	92L34900101001
	4 AM Loop Aerial	92L50100680101
	5 FM Aerial	92L28101510501
	6 iPhone Adaptor	See Contrast table (2)
	7 iPhone 3G Adaptor	See Contrast table (2)
	8 iPhone 4G Adaptor	See Contrast table (2)
	9 Operating Instructions (En, Fr, Es, De, It, Ni, Ru)	92L87500200101
	10 Front Packing Add	92L87000200101
	11 Rear Packing Add	92L87000200201
	12 Speaker Packing Add	See Contrast table (2)
	13 Miramat Bag Unit	92L89134045001
	14 Packing Case	See Contrast table (2)

(2) CONTRAST TABLE

X-HM20-K/SYXJC8, X-HM20-S/SYXJC8, X-HM10-K/SYXJC8 and X-HM10-S/SYXJC8 are constructed the same except for the following:

Mark	No.	Symbol and Description	X-HM20-K /SYXJC8	X-HM20-S /SYXJC8	X-HM10-K /SYXJC8	X-HM10-S /SYXJC8
	1	Speaker	92L33400201001	92L33400201001	92L33400101002	92L33400101002
	6	iPhone Adaptor	92L43200033101	92L43200033101	Not used	Not used
	7	iPhone 3G Adaptor	92L43200033201	92L43200033201	Not used	Not used
	8	iPhone 4G Adaptor	92L43200033301	92L43200033301	Not used	Not used
	12	Speaker Packing Add	92L87000200301	92L87000200301	92L87001510201	92L87001510201
	14	Packing Case	92L89600200102	92L89600200101	92L89600104102	92L89600104101

9.2 EXTERIOR SECTION

A

B

C

D

E

F

X-HM20-K,
X-HM20-S
only

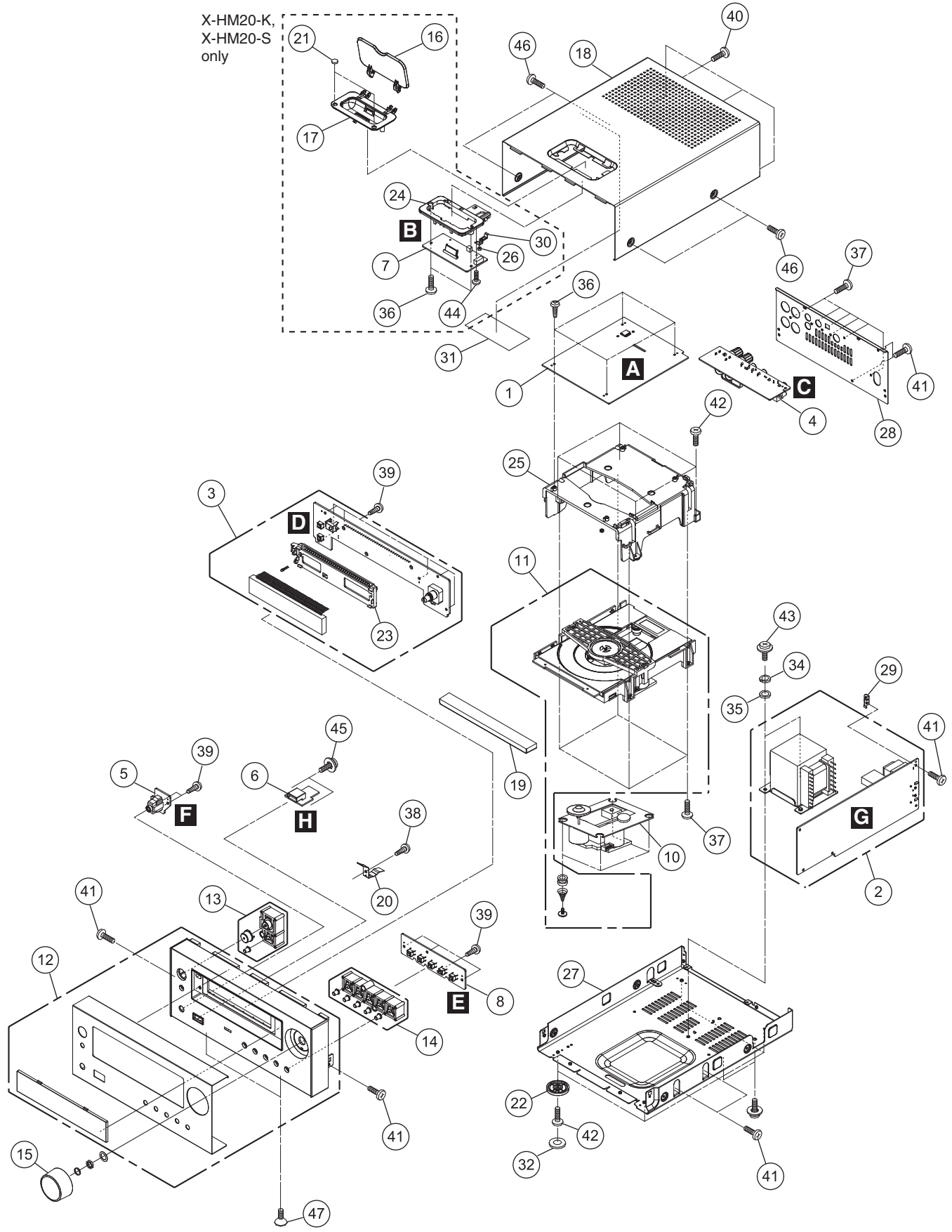

(1) EXTERIOR SECTION PARTS LIST

Mark No.	Description	Part No.	Mark No.	Description	Part No.
⚠	1 MAIN PCB Assy	See Contrast table (2)	26 Door Washer	See Contrast table (2)	
	2 POWER PCB Assy	See Contrast table (2)	27 Main Chassis	92L54500200101	A
	3 DISPLAY PCB Assy	See Contrast table (2)	28 Rear Panel	See Contrast table (2)	
	4 RADIO PCB Assy	See Contrast table (2)	29 PWB Bracket	92L72900200101	
	5 HEADPHONE PCB Assy	See Contrast table (2)	30 Spring Plate	See Contrast table (2)	
6 USB PCB Assy	See Contrast table (2)	31 Laser Label	92L88900200201		
7 IPOD PCB Assy	See Contrast table (2)	32 Leg Cushion	92L48300200101		
8 KEY-SWITCH PCB Assy	See Contrast table (2)	33 •••••			
9 •••••		34 Washer	92L65004000101		
10 CD MECHA Unit	92L28700220301	35 Washer	92L65004000201		
11 LOADER Assy	92L5150020071T	36 Screw	BBZ30P080FTC	B	
12 Front Cabinet Assy	See Contrast table (2)	37 Screw	BBZ30P100FTC		
13 Power Button Assy	See Contrast table (2)	38 Screw 2.6x6	92L75526906001		
14 Operation Button	See Contrast table (2)	39 Screw 2.6x8	92L75526908001		
15 Volume Knob	See Contrast table (2)	40 Screw 3.0x6	92L75603006001		
16 iPod Door	See Contrast table (2)	41 Screw 3.0x6	92L75603006002		
17 iPod Holder	See Contrast table (2)	42 Screw 3.0x8	92L75603008001		
18 Top Cabinet	See Contrast table (2)	43 Screw 4.0x8	92L75604008001		
19 Disc Tray Cover	See Contrast table (2)	44 Screw	92L77017906001		
20 ESD Sheet	92L45900200101	45 Screw 2.6x8	92L78026908002	C	
21 iPod Door Cushion	See Contrast table (2)	46 Screw 3.0x6	See Contrast table (2)		
22 Leg	92L48301510201	47 Screw 3.0x8	See Contrast table (2)		
23 FL Holder	92L51500200101				
24 iPod Spacer	See Contrast table (2)				
25 CD Mecha Holder	92L51501510101				

(2) CONTRAST TABLE

X-HM20-K/SYXJC8, X-HM20-S/SYXJC8, X-HM10-K/SYXJC8 and X-HM10-S/SYXJC8 are constructed the same except for the following:

Mark	No.	Symbol and Description	X-HM20-K /SYXJC8	X-HM20-S /SYXJC8	X-HM10-K /SYXJC8	X-HM10-S /SYXJC8
⚠	1	MAIN PCB Assy	92L36100201011	92L36100201011	92L36100101011	92L36100101011
	2	POWER PCB Assy	92L36800201010	92L36800201010	92L36800101010	92L36800101010
	3	DISPLAY PCB Assy	92L36500201010	92L36500201010	92L36500101010	92L36500101010
	4	RADIO PCB Assy	92L36400201010	92L36400201010	92L36400101010	92L36400101010
	5	HEADPHONE PCB Assy	92L37100201011	92L37100201011	92L37100101011	92L37100101011
6	USB PCB Assy	92L36900201011	92L36900201011	92L36900101011	92L36900101011	
7	IPOD PCB Assy	92L36600201010	92L36600201010	Not used	Not used	
8	KEY-SWITCH PCB Assy	92L37200201010	92L37200201010	92L37200101011	92L37200101011	
12	Front Cabinet Assy	92L20100200102	92L20100200101	92L20100100102	92L20100100101	
13	Power Button Assy	92L20700200102	92L20700200101	92L20700200102	92L20700200101	
14	Operation Button	92L20800200102	92L20800200101	92L20800200102	92L20800200101	
15	Volume Knob	92L20900300102	92L20900300102	92L20900300102	92L20900300102	
16	iPod Door	92L40300200102	92L40300200101	Not used	Not used	
17	iPod Holder	92L40300200202	92L40300200201	Not used	Not used	
18	Top Cabinet	92L43100200103	92L43100200101	92L43100100201	92L43100100101	
19	Disc Tray Cover	92L43800200102	92L43800200101	92L43800200102	92L43800200101	
21	iPod Door Cushion	92L48300200501	92L48300200401	Not used	Not used	
24	iPod Spacer	92L51500200201	92L51500200201	Not used	Not used	
26	Door Washer	92L51501510501	92L51501510501	Not used	Not used	
28	Rear Panel	92L70200200102	92L70200200101	92L70200100102	92L70200100101	
30	Spring Plate	92L73000200101	92L73000200101	Not used	Not used	
46	Screw 3.0x6	92L75603006002	92L75603006001	92L75603006002	92L75603006001	
47	Screw 3.0x8	92L76503008013	92L76503008012	92L76503008013	92L76503008012	

10. SCHEMATIC DIAGRAM

10.1 MAIN PCB ASSY (1/7)

A1/7 MAIN PCB ASSY (X-HM20: 92L36100201011) (X-HM10: 92L36100101011)

USB_ID H for slave mode,L for Host mode

1. 1.8v LDO 250uA(output)500uA(input) at 32KHz with SD_clk 32KHz output
2. VDD_3v3 1.5mA at 32KHz

C78	NA
C80	NA
C81	NA
C82	NA
C77	1nF

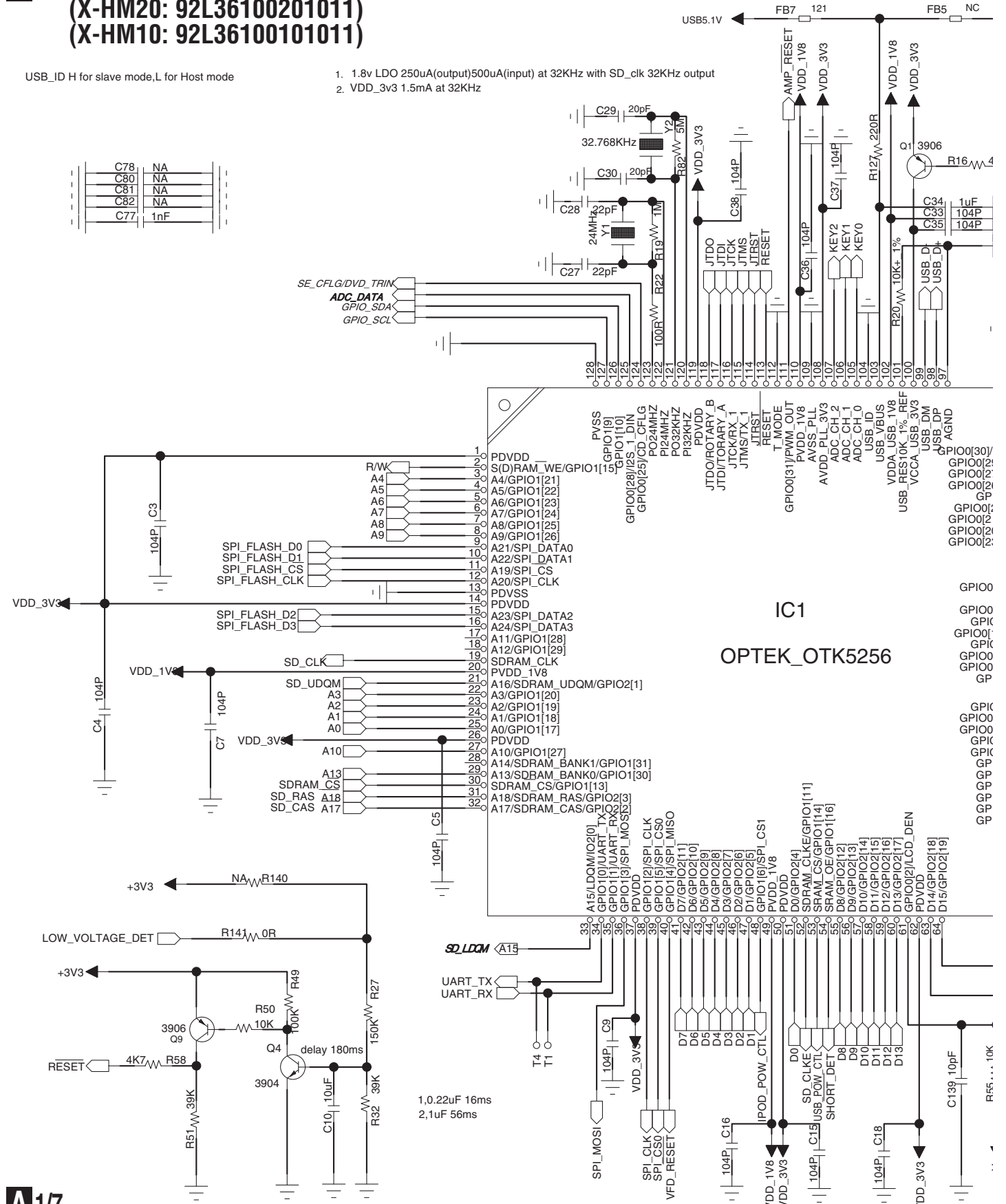

A1/7

10.2 MAIN PCB ASSY (2/7)

A 2/7 MAIN PCB ASSY
 (X-HM20: 92L36100201011)
 (X-HM10: 92L36100101011)

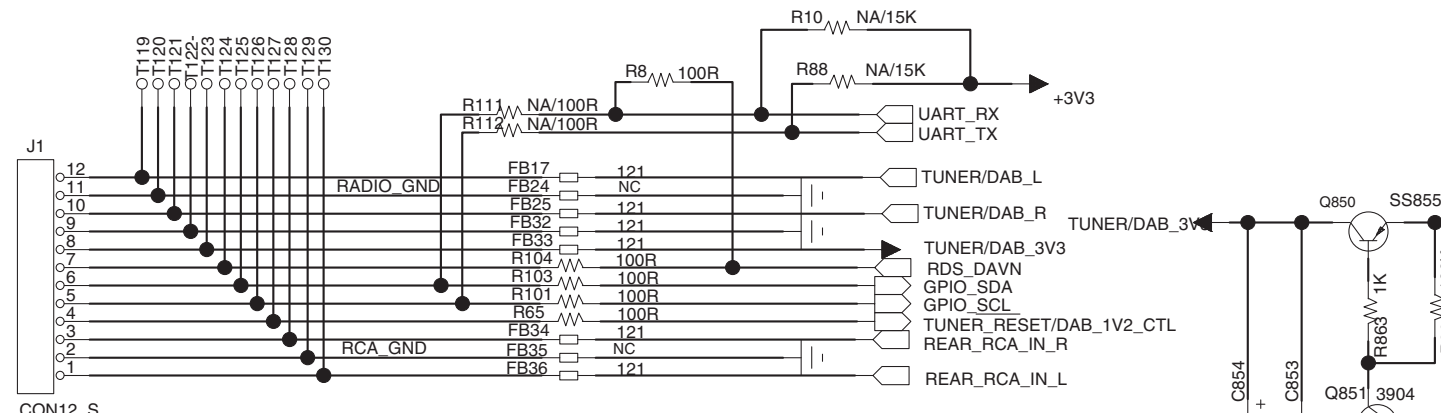
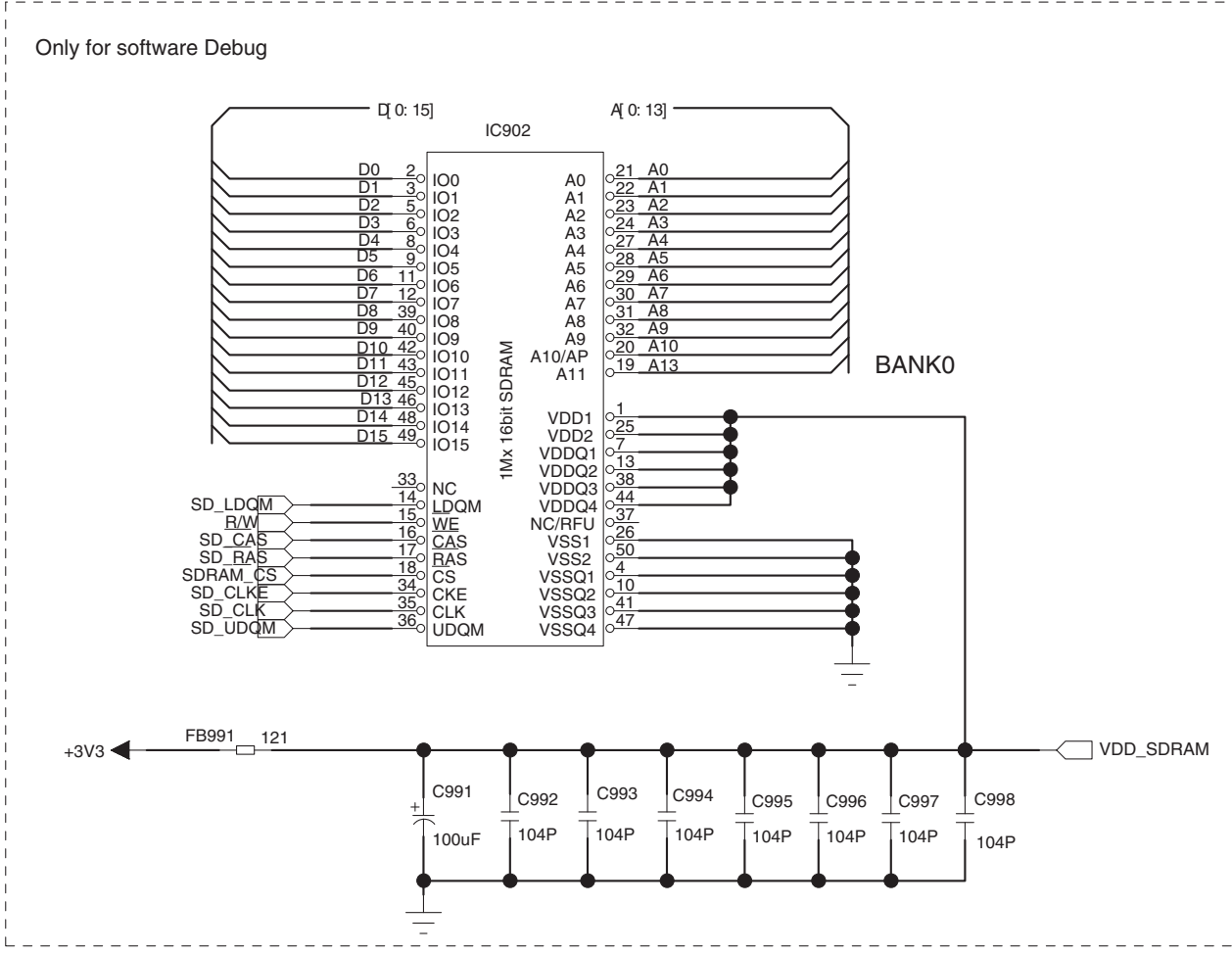

Note: don't populate
 1, In the Tuner: R111, R112, R10, R88
 2, In the DAB mode: R101, R103, R104, R8

must be delayed to 100ms when present 3v3

A 2/7
 26

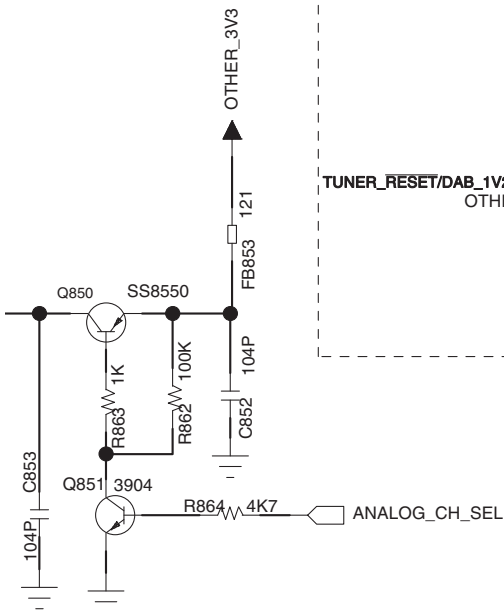
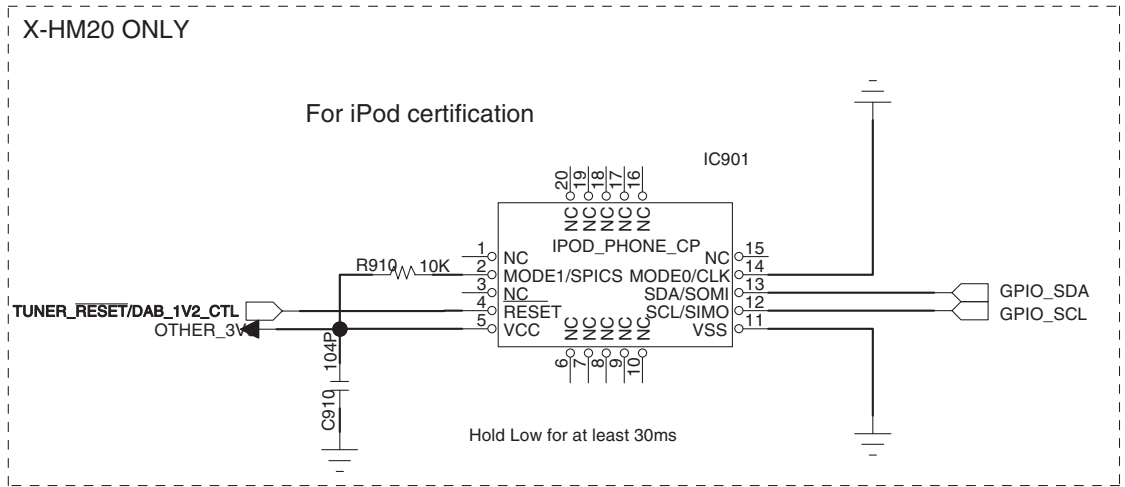
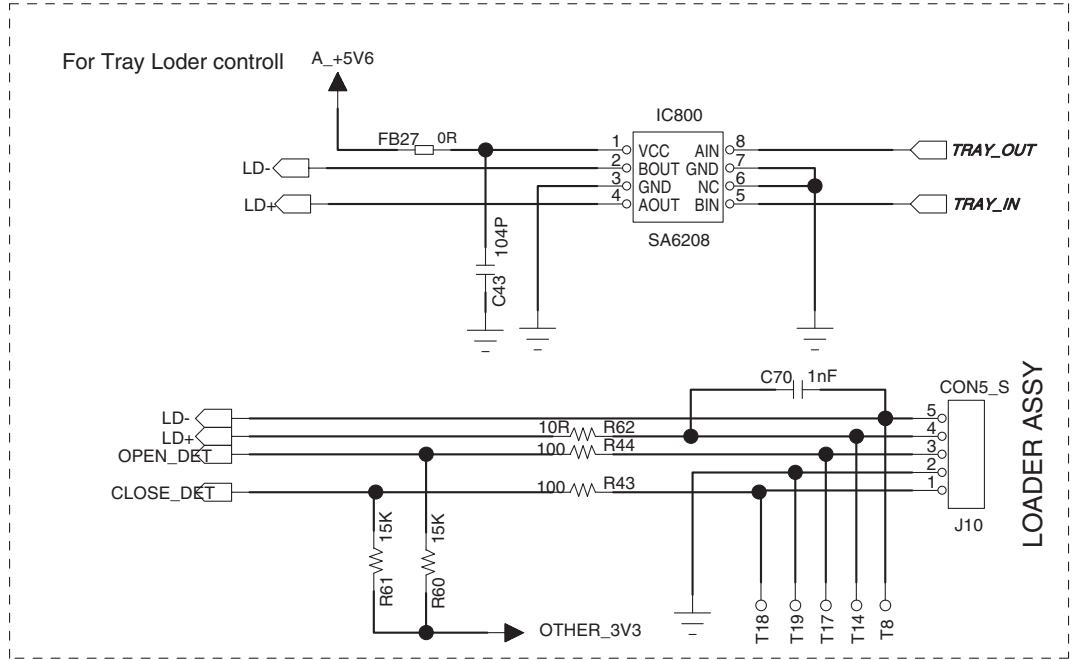

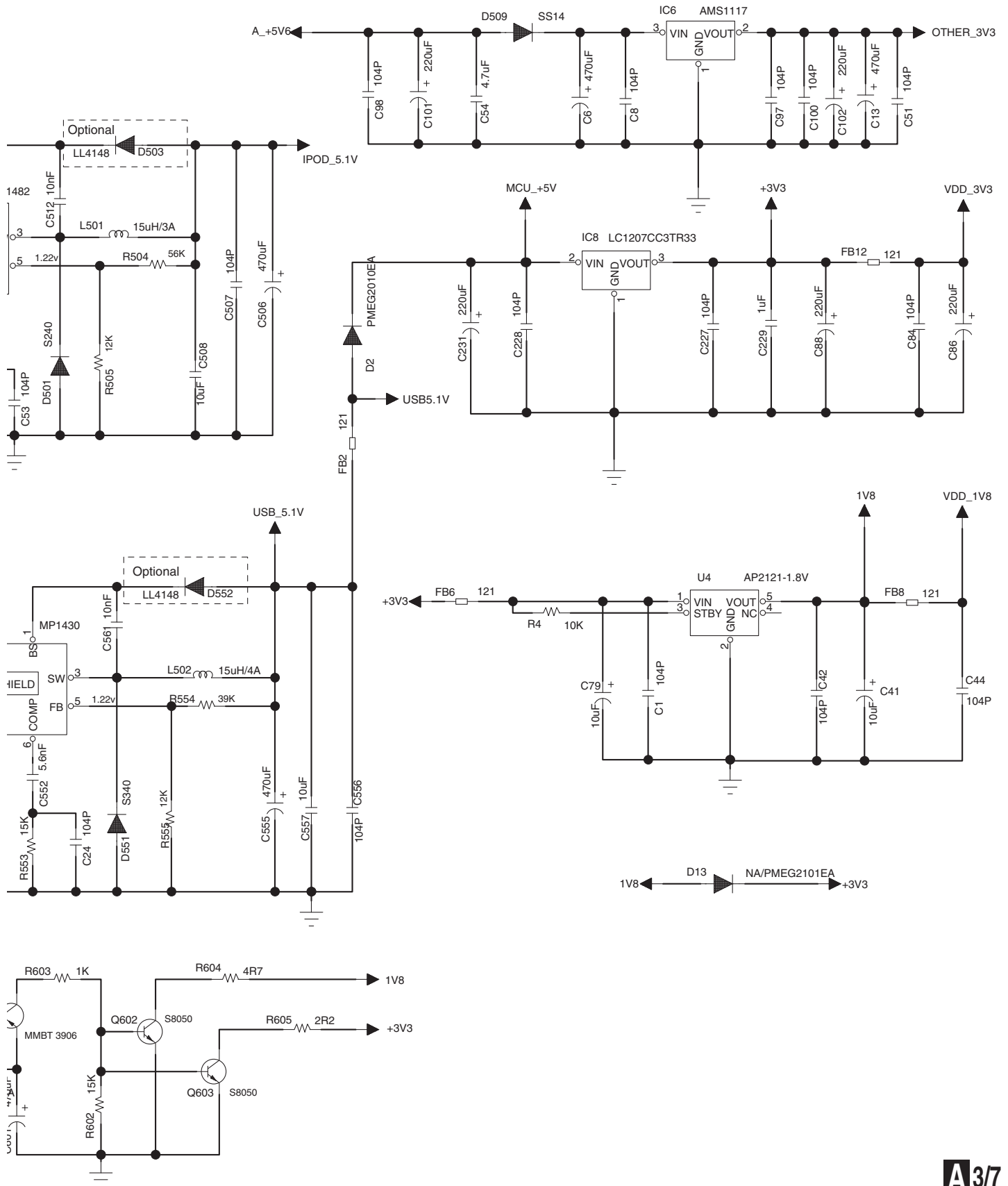

10.4 MAIN PCB ASSY (4/7)

A 4/7 MAIN PCB ASSY
 (X-HM20: 92L36100201011)
 (X-HM10: 92L36100101011)

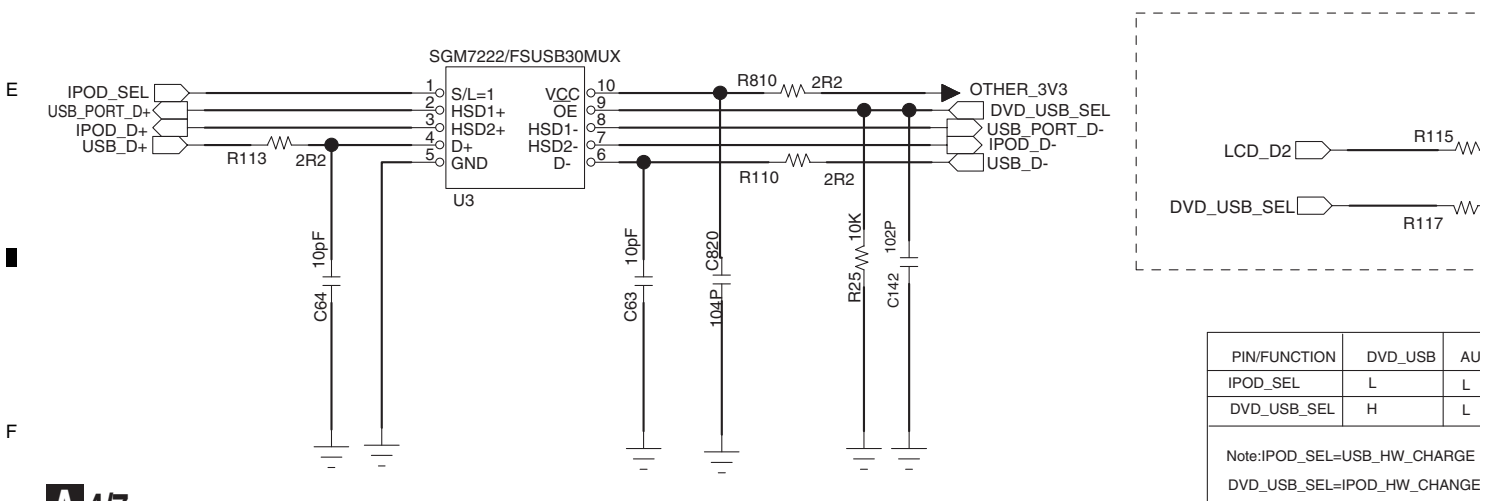
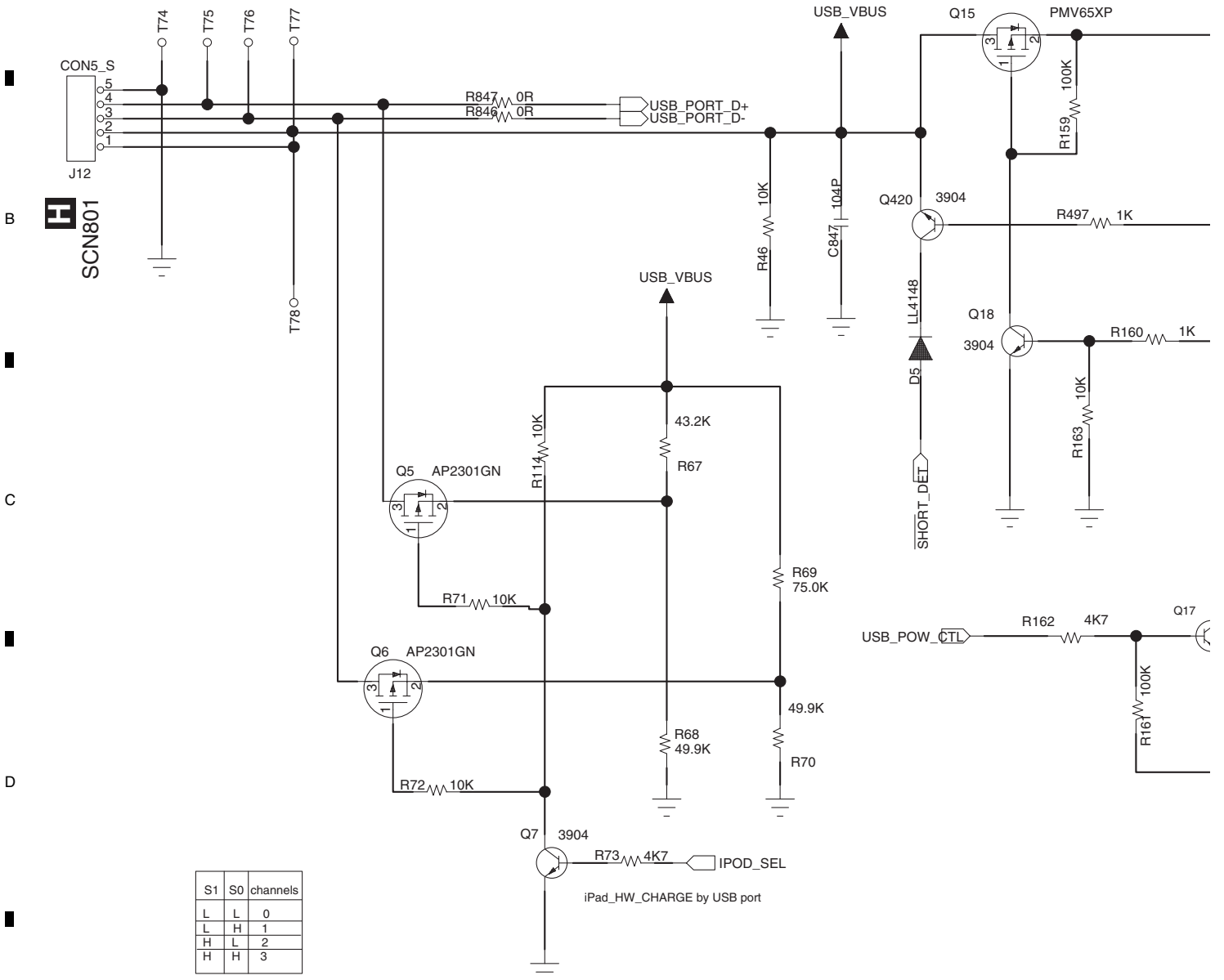

A 4/7

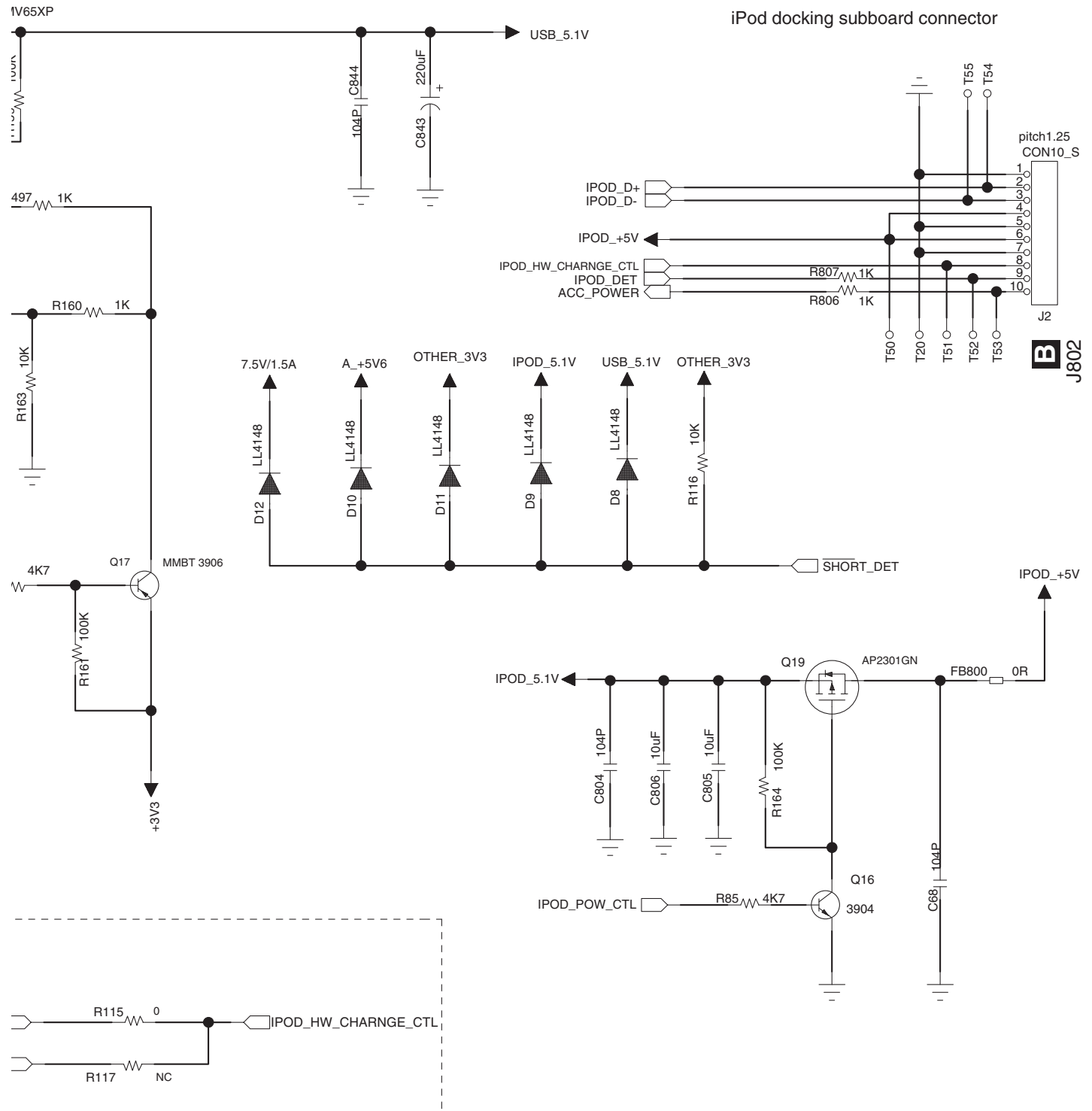

FUNCTION	DVD_USB	AUDIO_USB	iPod_USB	Non_USB/iPod mode	DEFAULT
	L	L	H		H
SEL	H	L	L		H

SEL=USB_HW_CHARGE
SEL=IPOD_HW_CHARGE

10.5 MAIN PCB ASSY (5/7)

Class_D_AMP

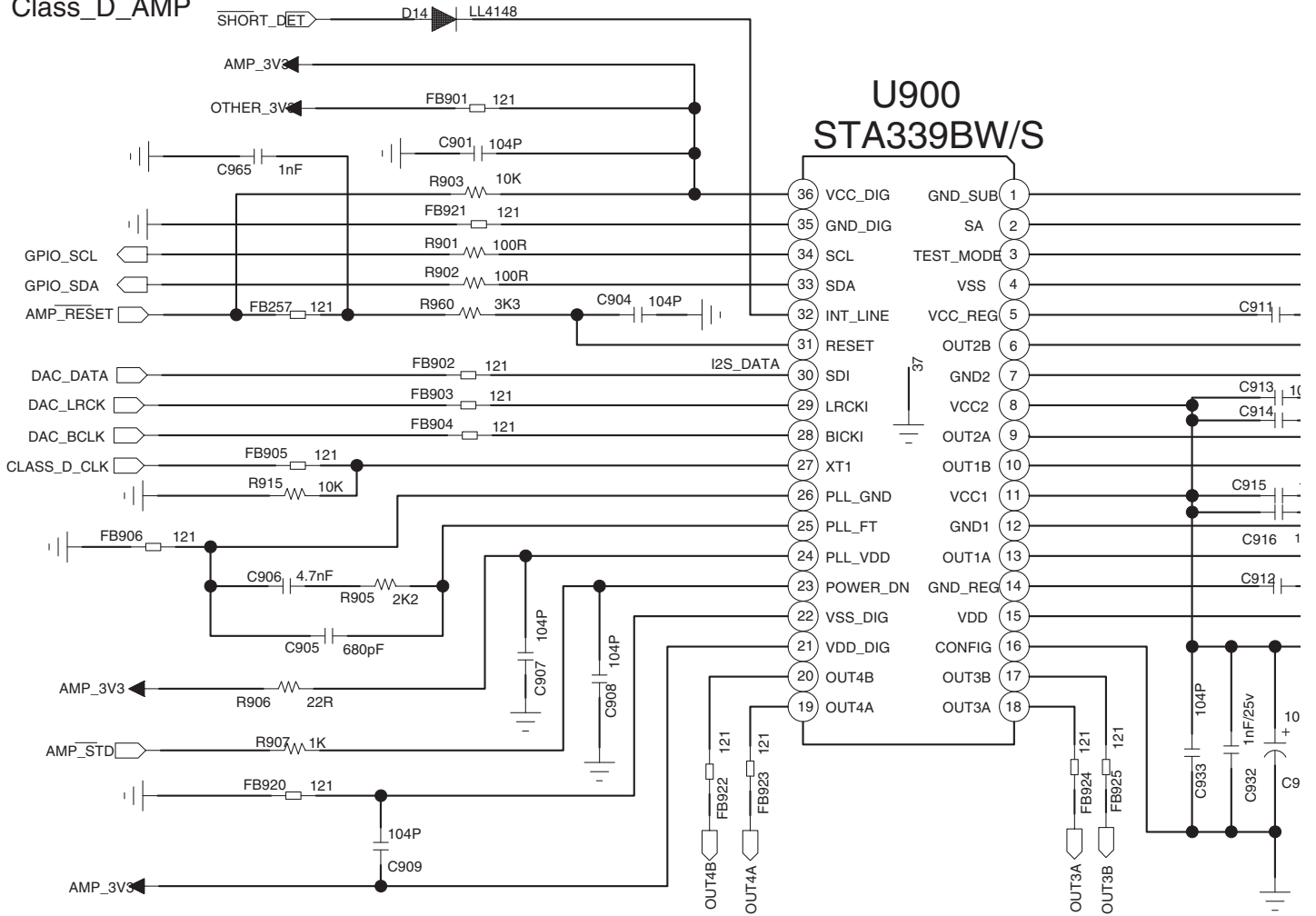

Headphone circuit section

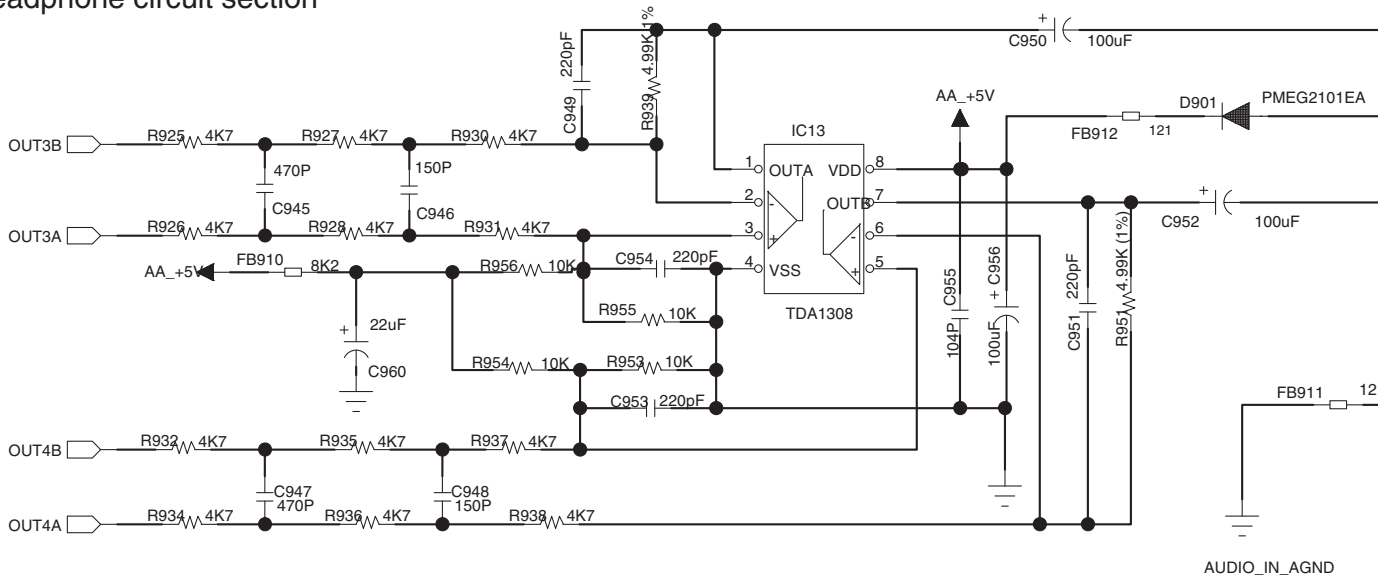

A5/7 MAIN PCB ASSY
 (X-HM20: 92L36100201011)
 (X-HM10: 92L36100101011)

10uH,1uF,220nF ,2R7 value for 4ohm speak

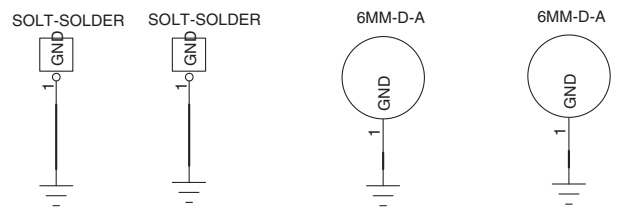
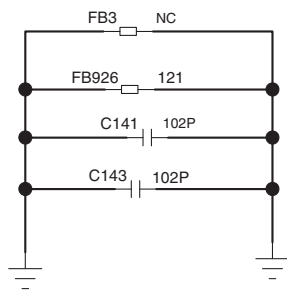
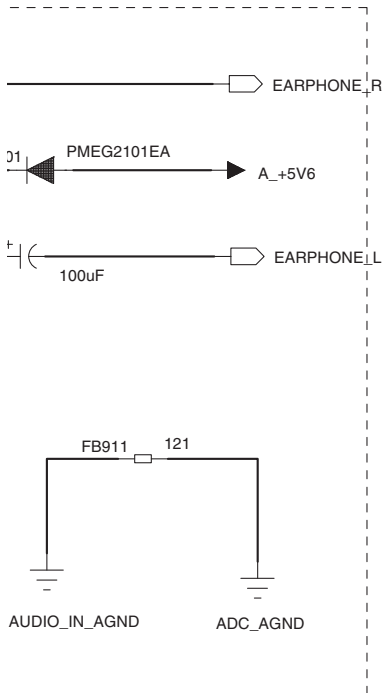
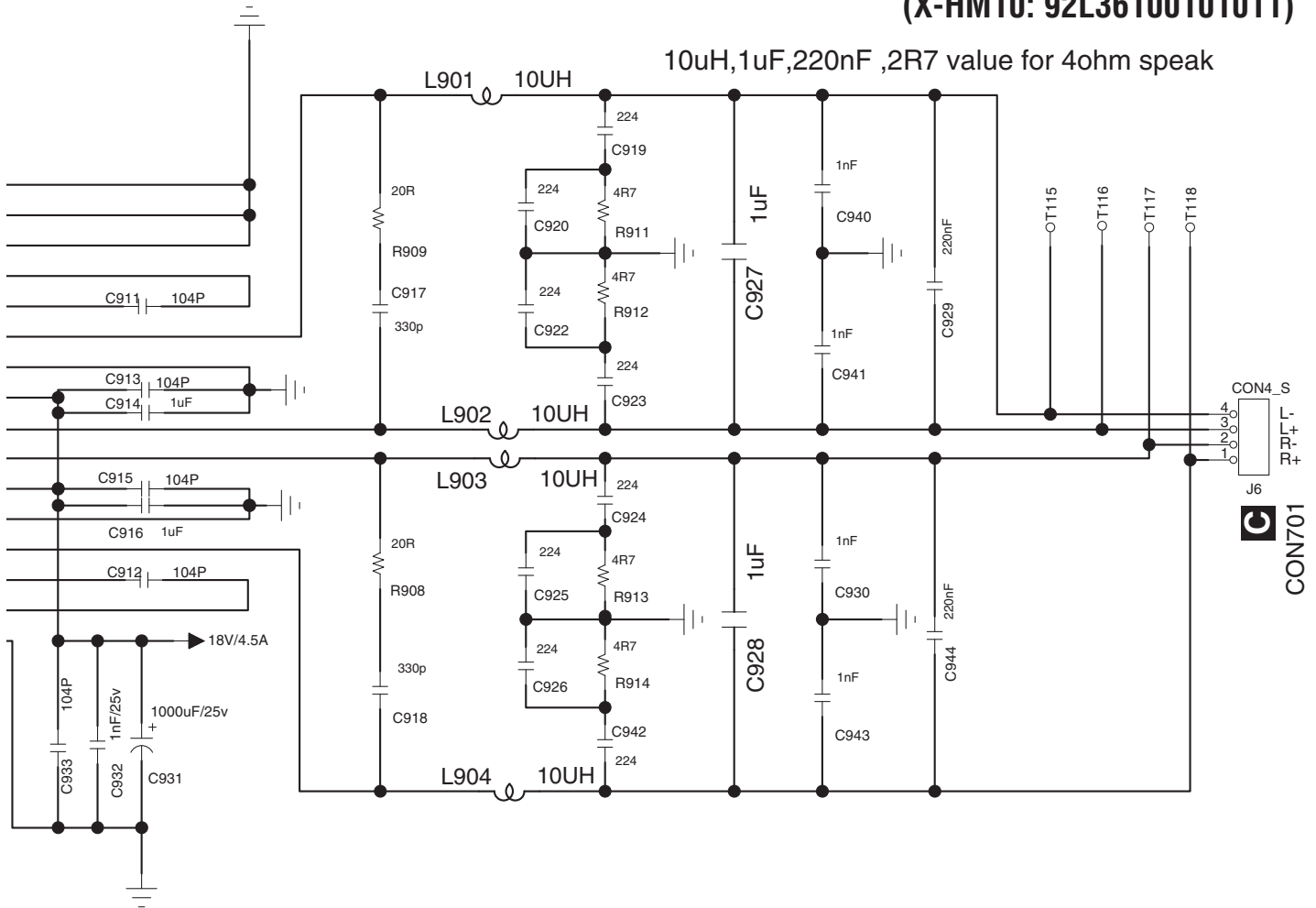

C CON701

10.6 MAIN PCB ASSY (6/7)

A 6/7 MAIN PCB ASSY (X-HM20: 92L36100201011) (X-HM10: 92L36100101011)

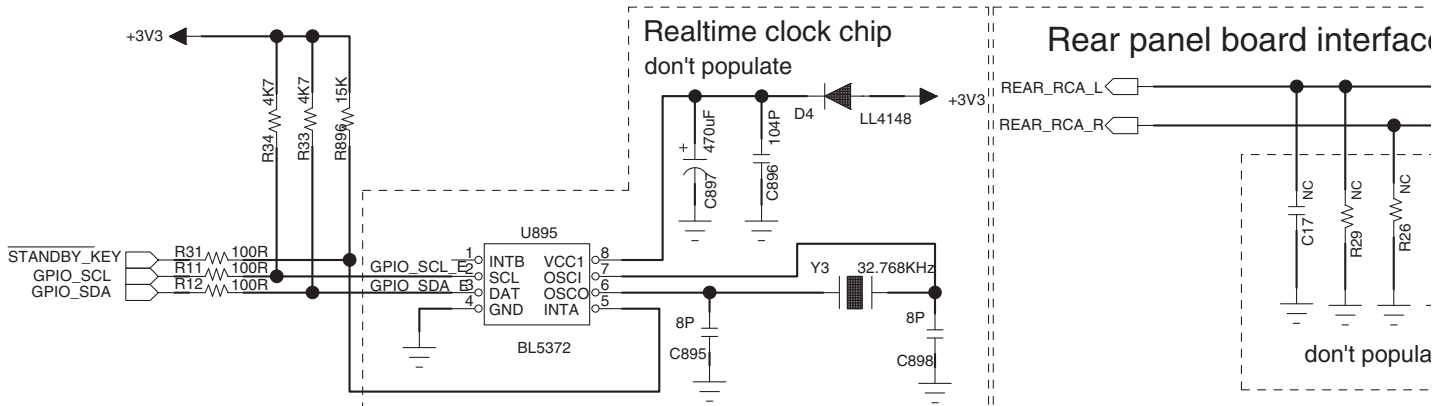
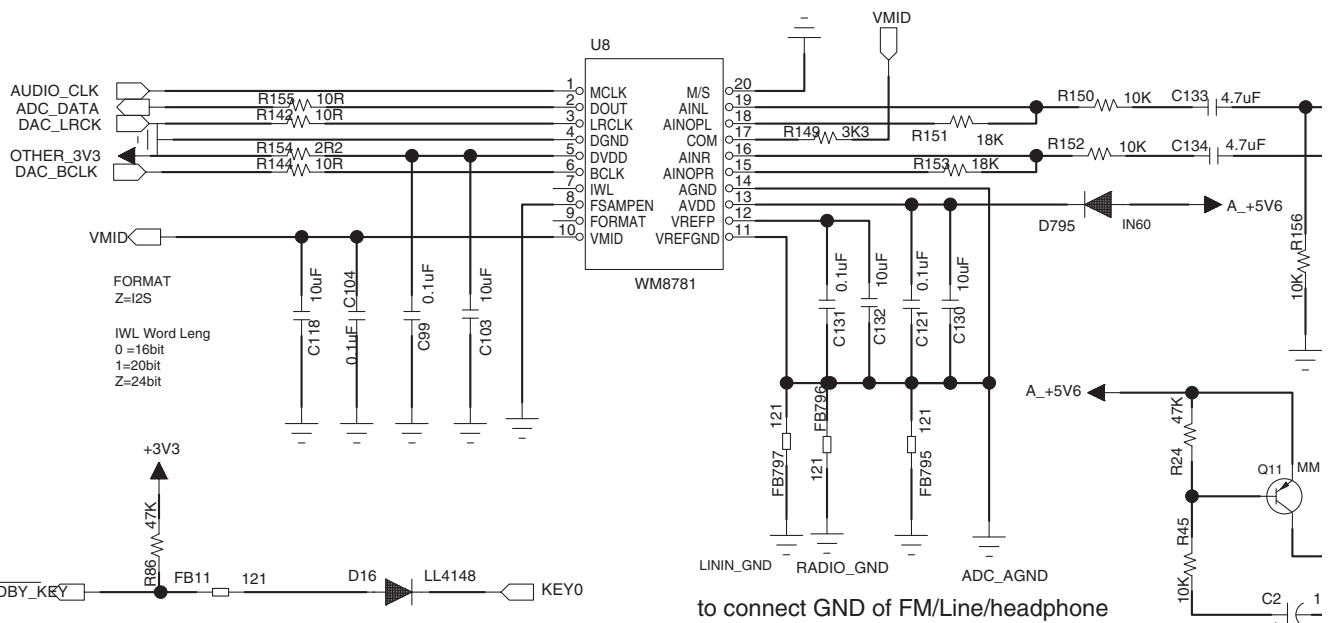
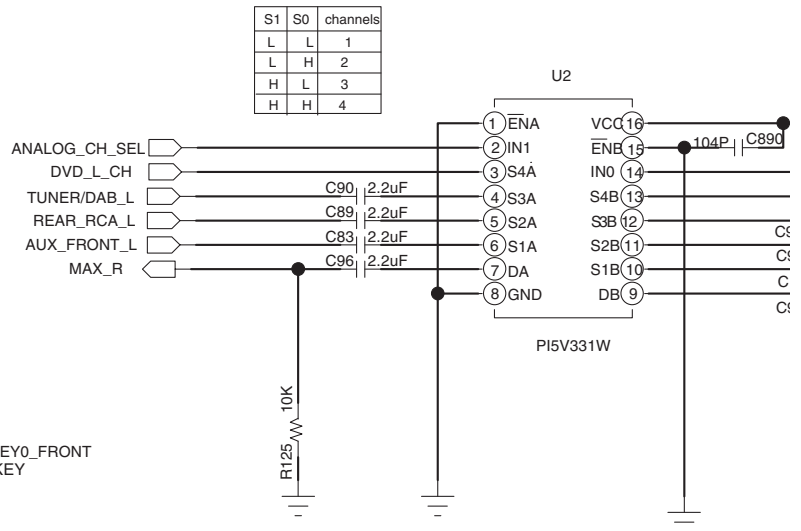
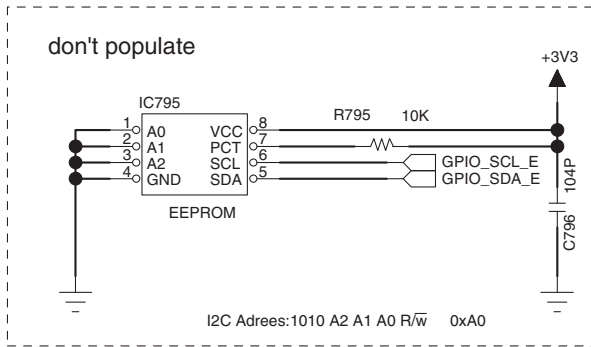

Front panel board interface

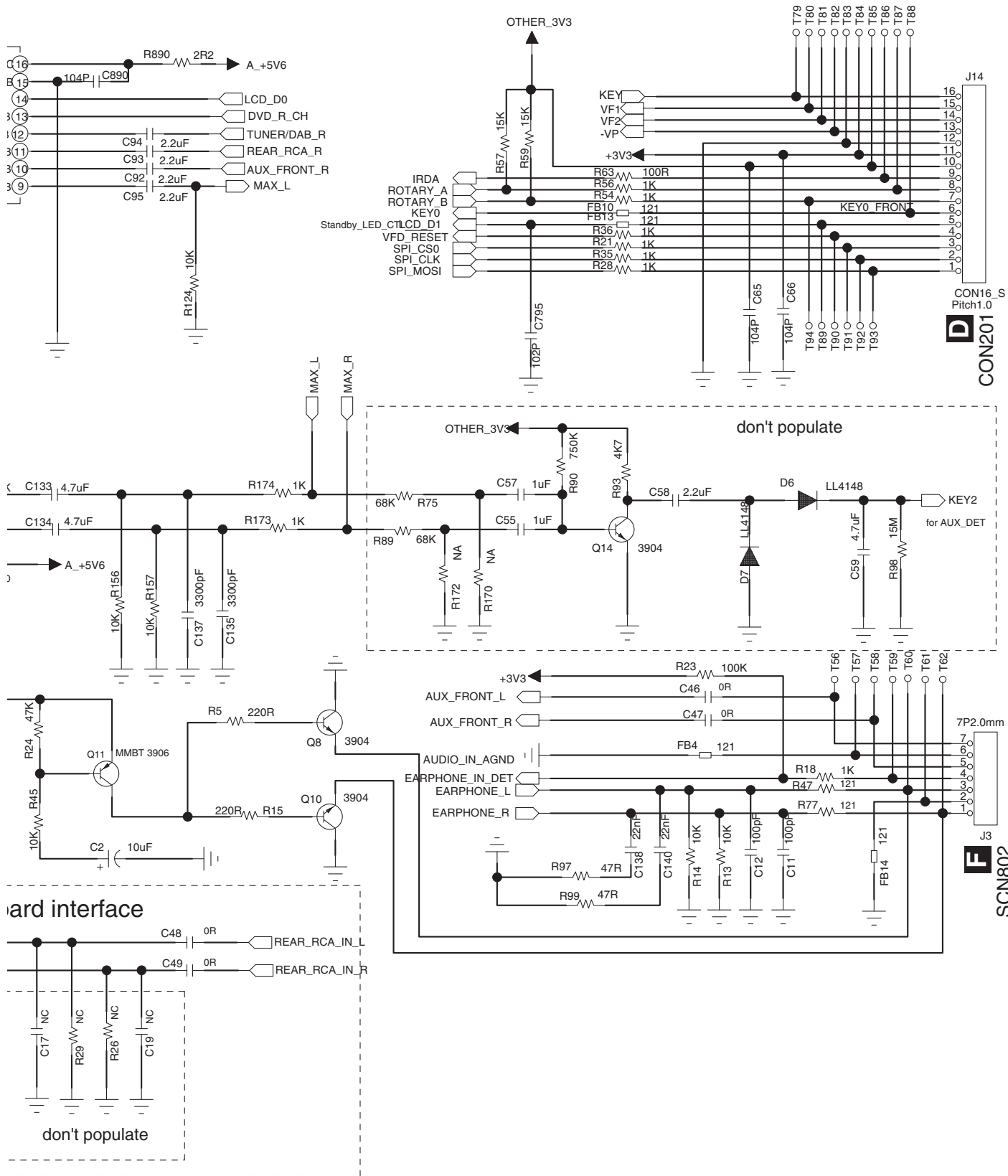

10.7 MAIN PCB ASSY (7/7)

A77 MAIN PCB ASSY
 (X-HM20: 92L36100201011)
 (X-HM10: 92L36100101011)

CD Section

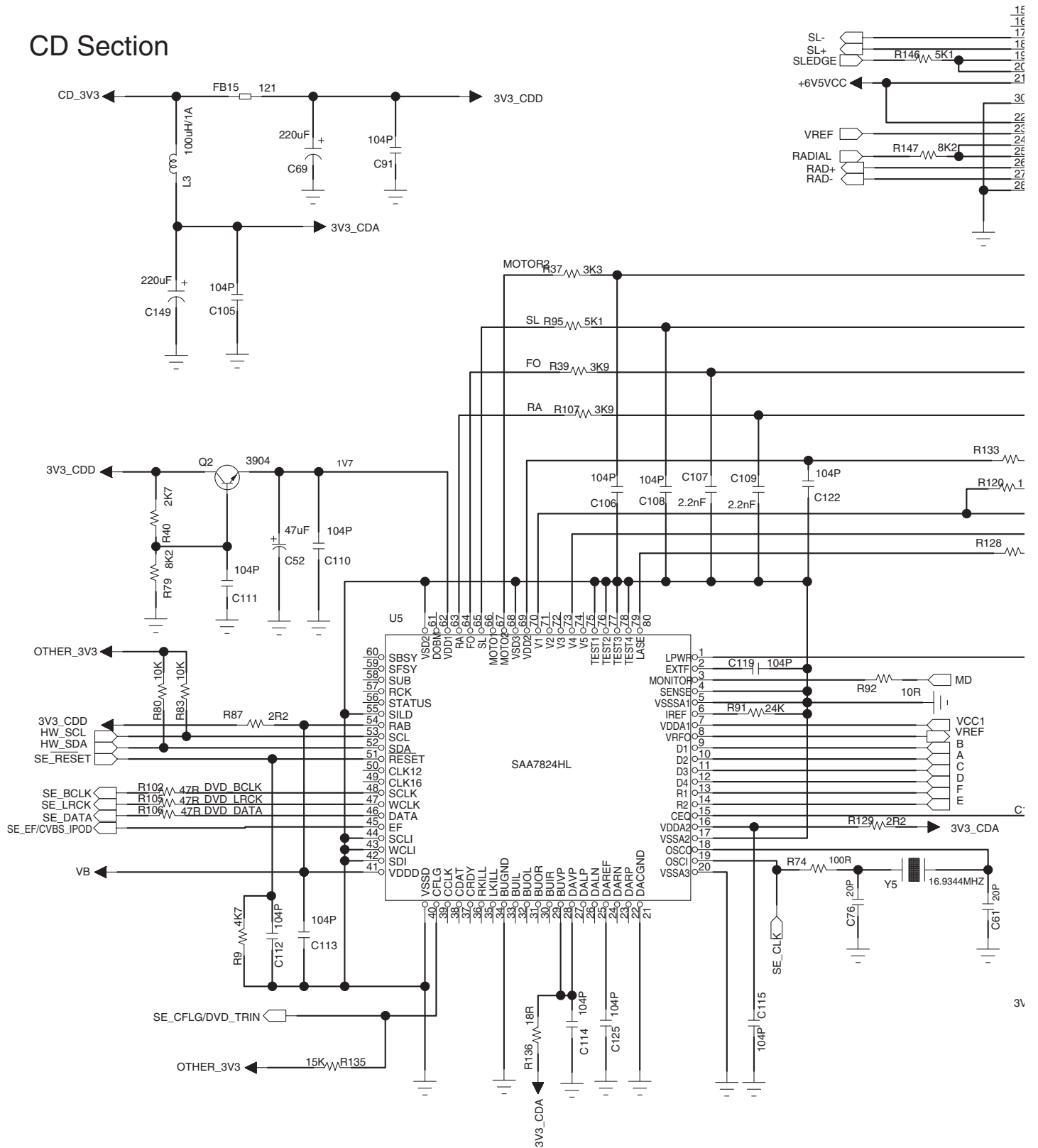

A
B
C
D
E
F

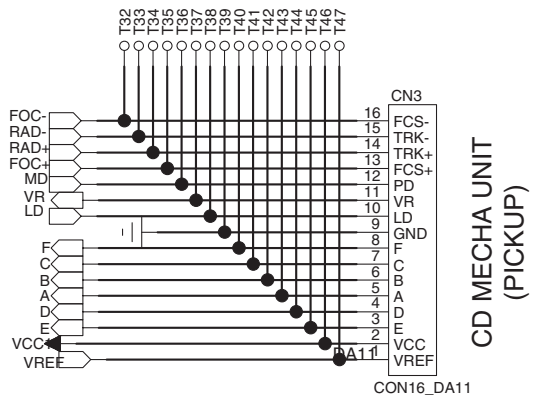
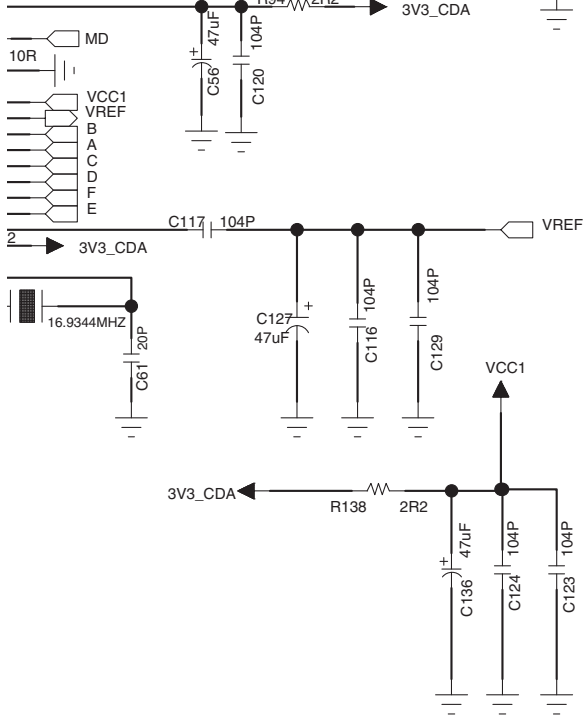
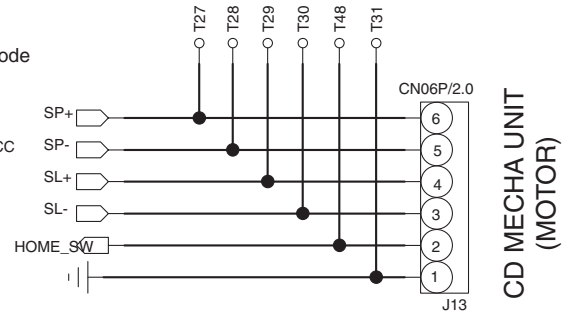
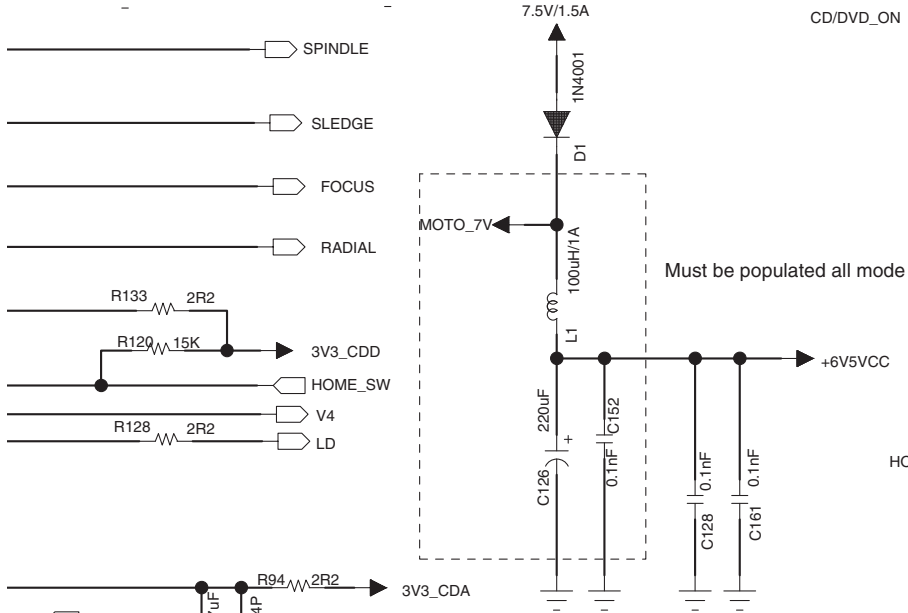
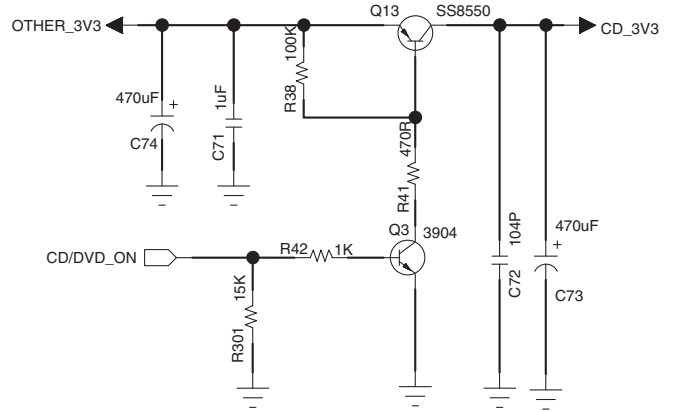
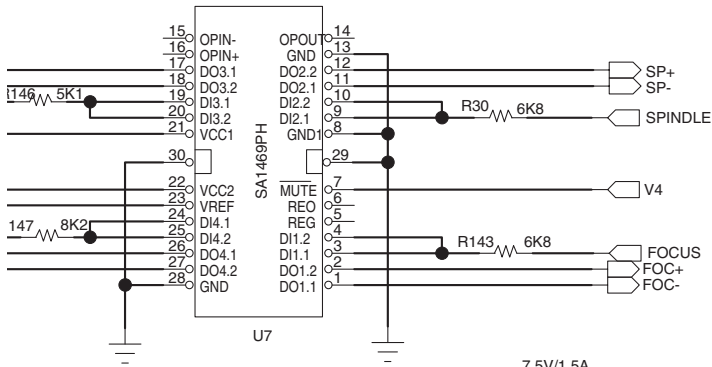

10.8 IPOD PCB ASSY (X-HM20 ONLY)

B IPOD PCB ASSY (92L36600201010)

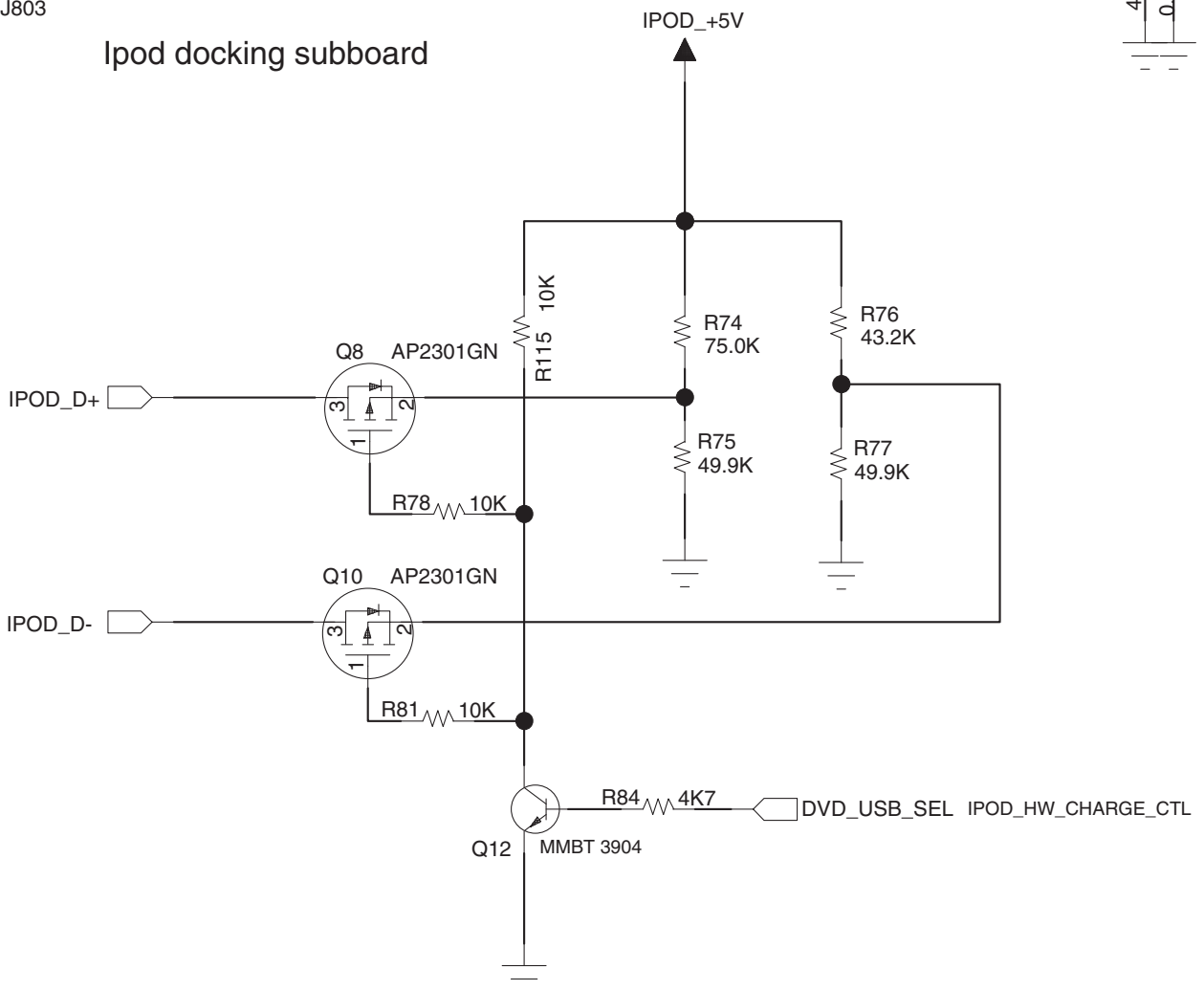
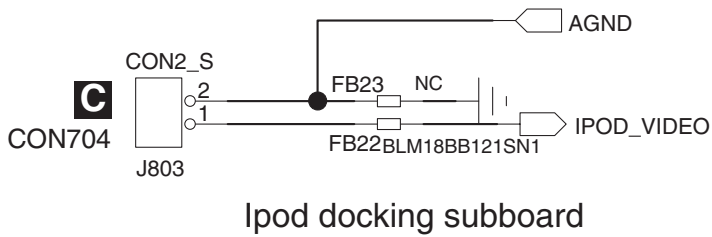
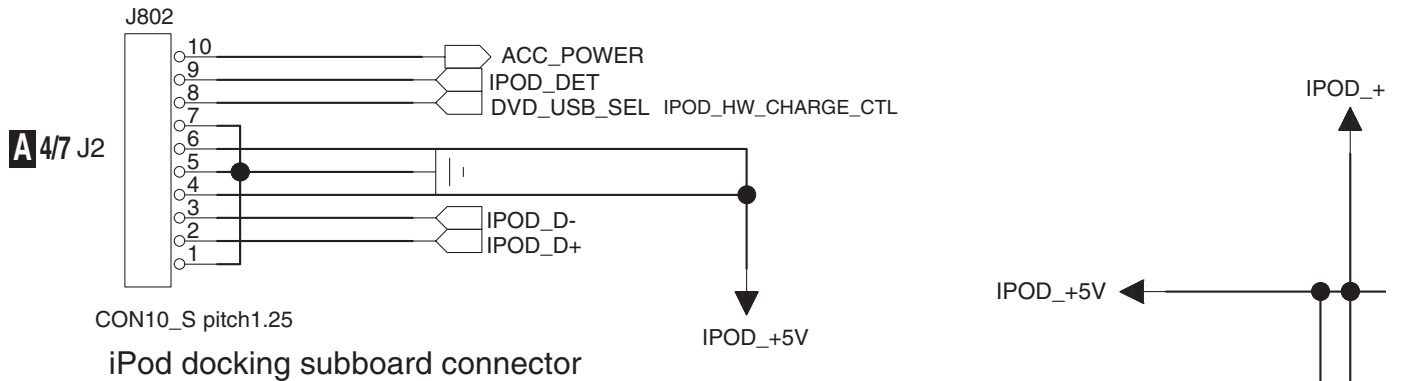

B

J801
iPOD 30pin Docking socket

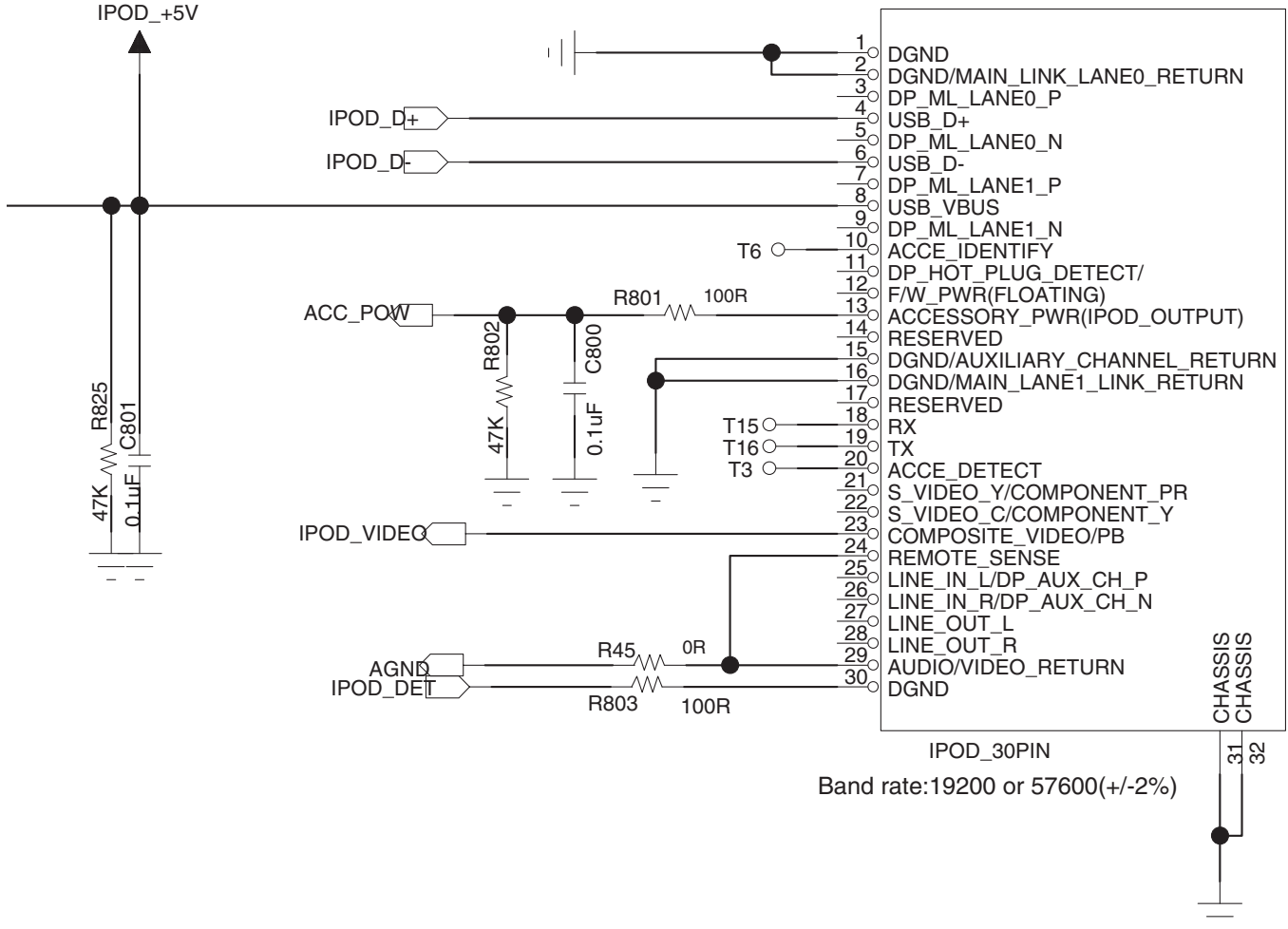

iPod

W_CHARGE_CTL

10.9 RADIO PCB ASSY

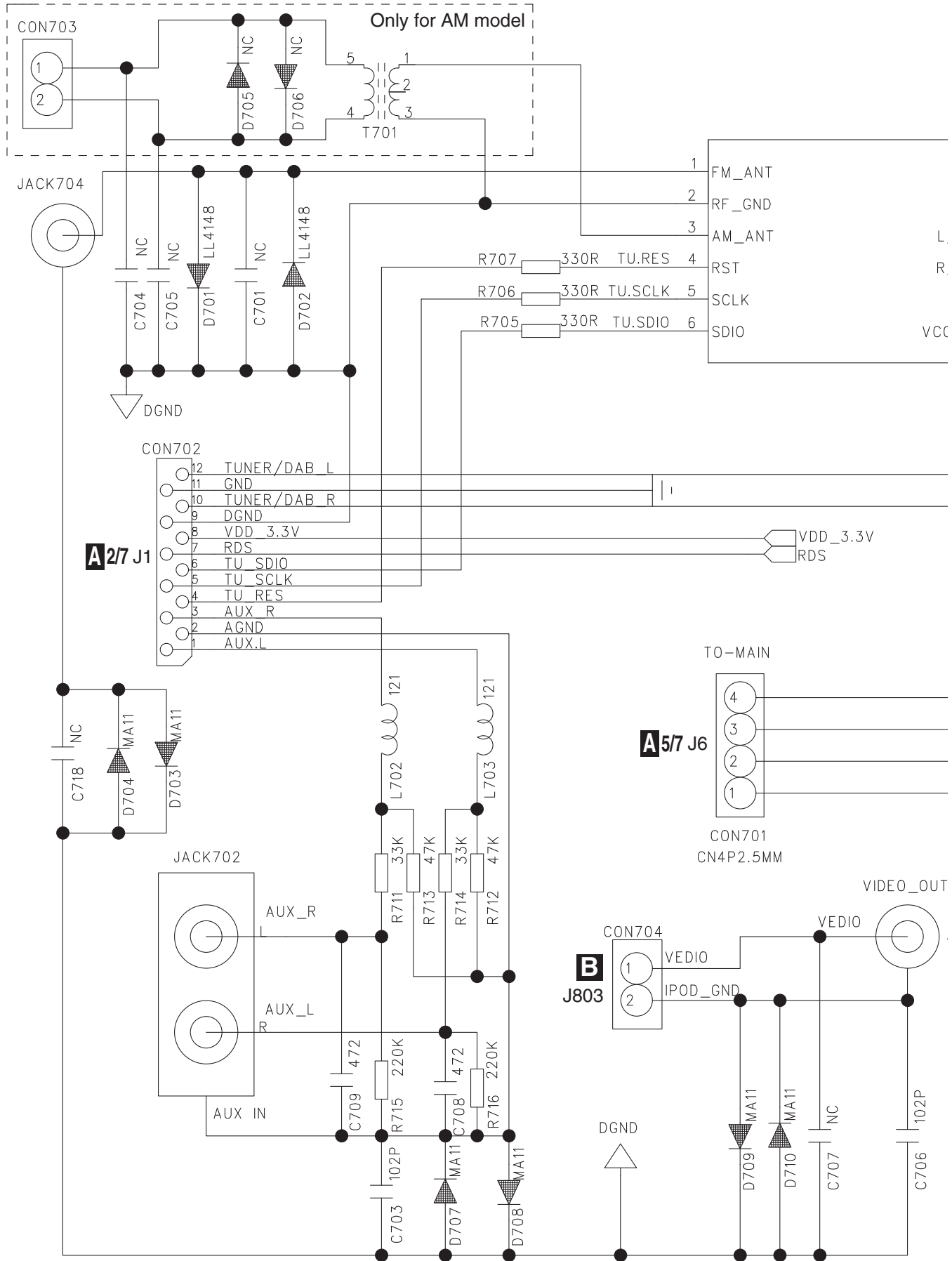

C
40

X-HM20-K

C RADIO PCB ASSY
 (X-HM20: 92L36400201010)
 (X-HM10: 92L36400101010)

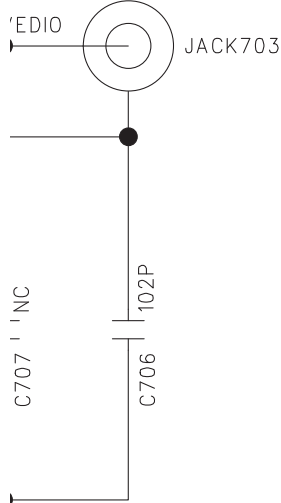
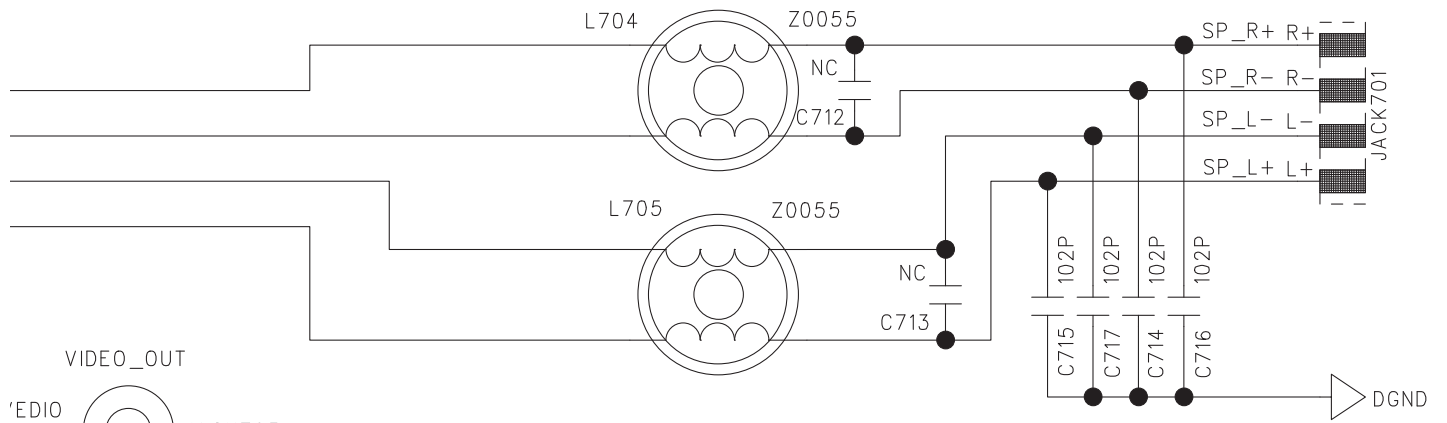
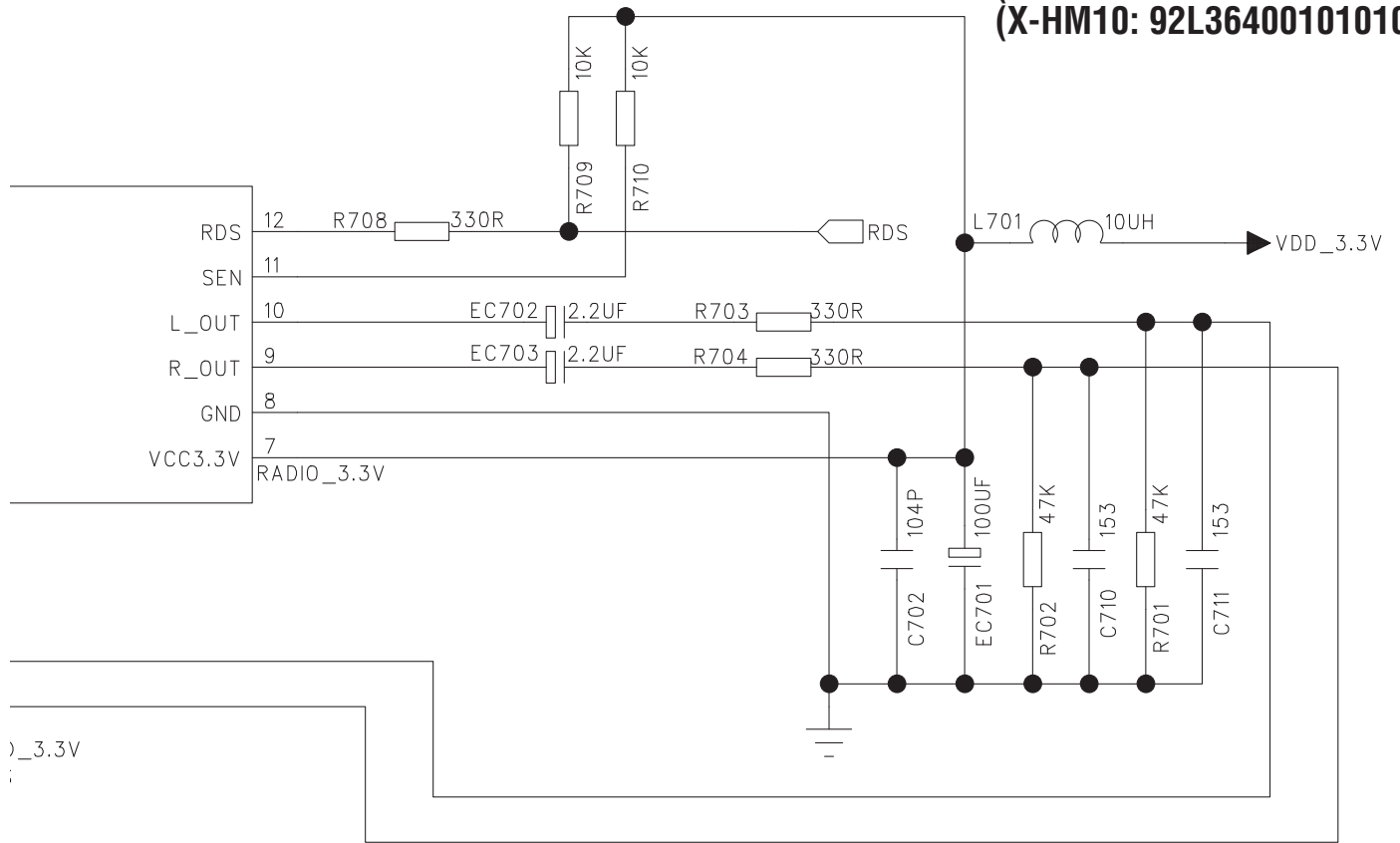

10.10 DISPLAY PCB ASSY

D DISPLAY PCB ASSY
 (X-HM20: 92L36500201010)
 (X-HM10: 92L36500101010)

LCD201
 HNA-16SM21T

P A T T E

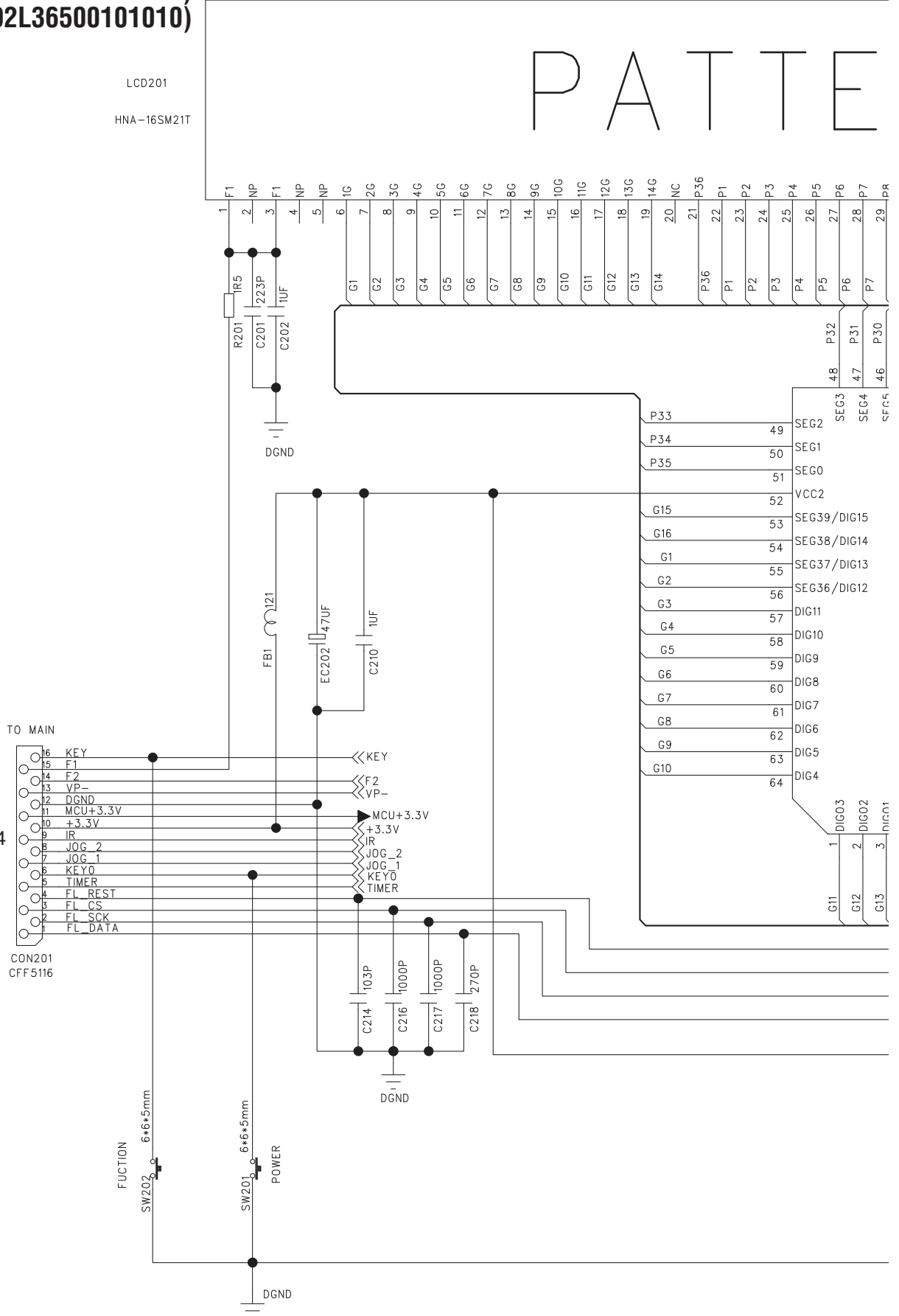

A 6/7 J14

D

TERN ARE A

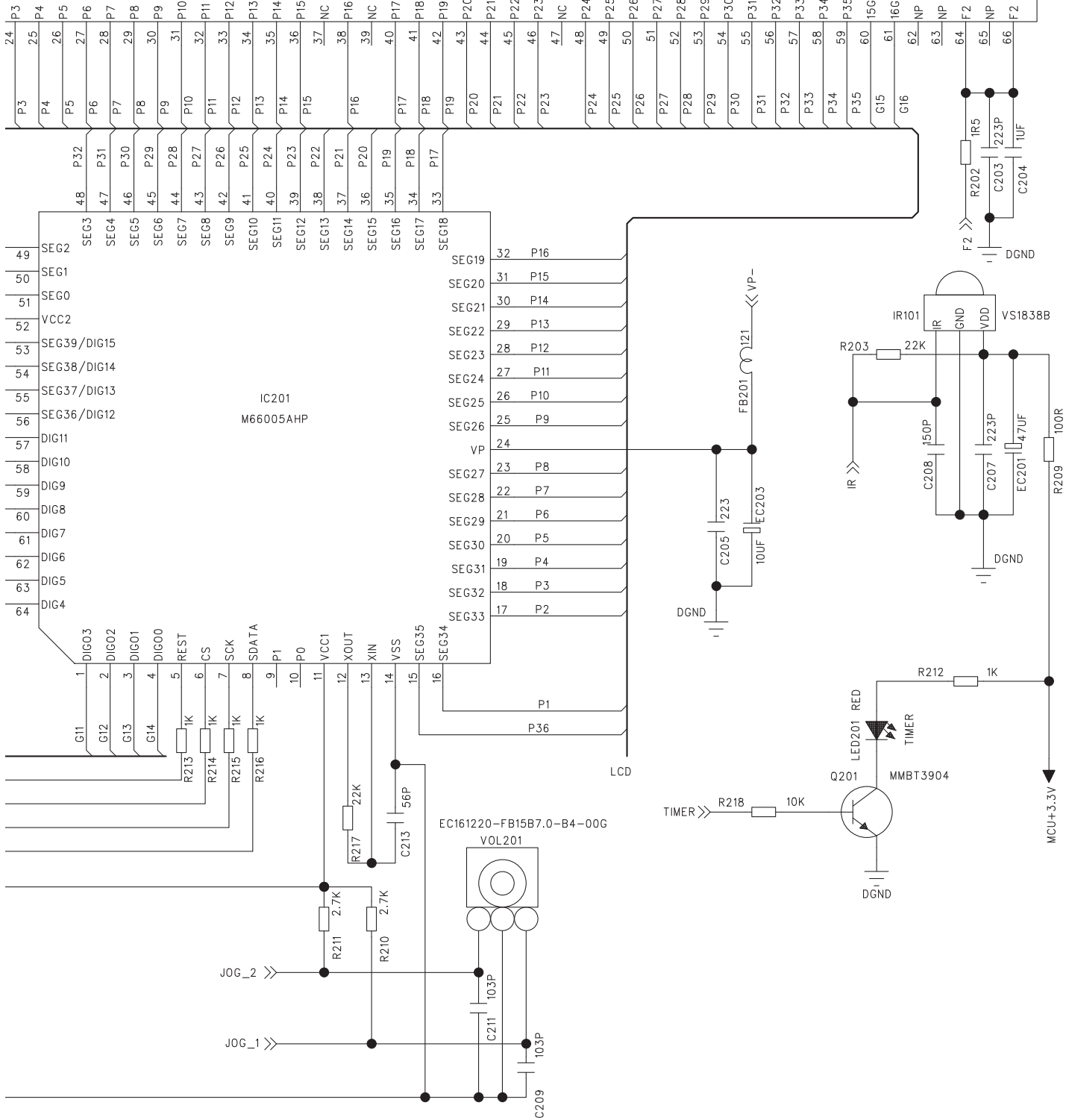

10.11 KEY-SWITCH PCB ASSY

E KEY-SWITCH PCB ASSY
 (X-HM20: 92L37200201010)
 (X-HM10: 92L37200101011)

A
B
C
D
E
F

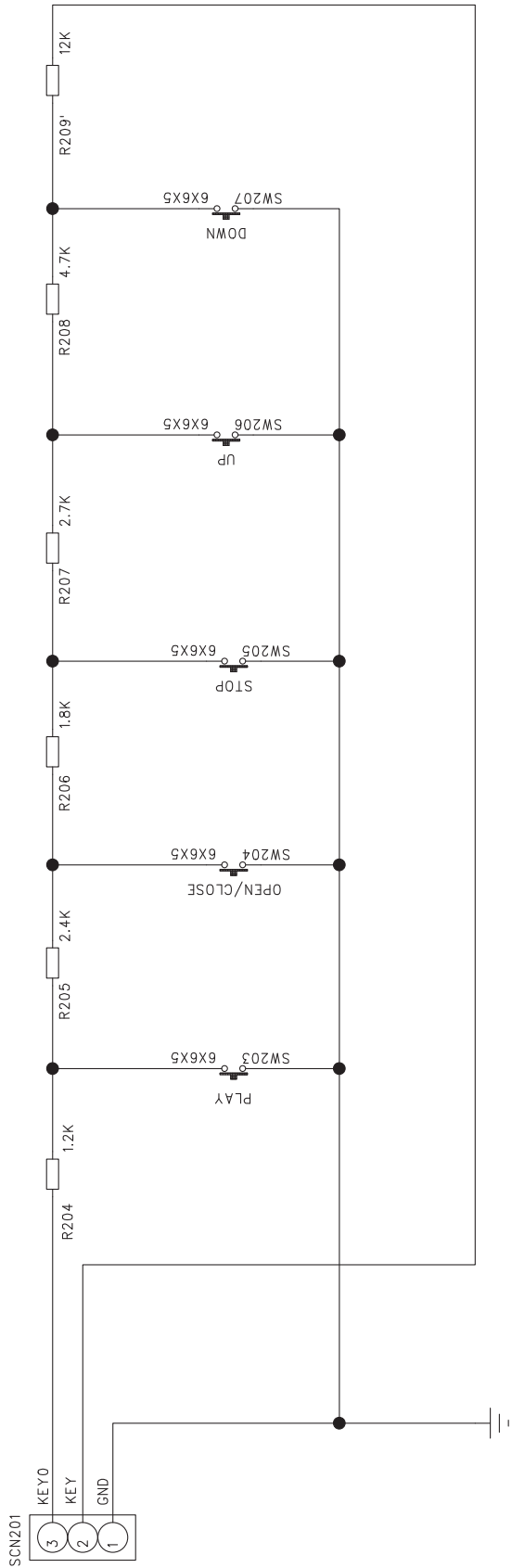

A 6/7 J5

E

10.12 HEADPHONE PCB ASSY

F HEADPHONE PCB ASSY
 (X-HM20: 92L37100201011)
 (X-HM10: 92L37100101011)

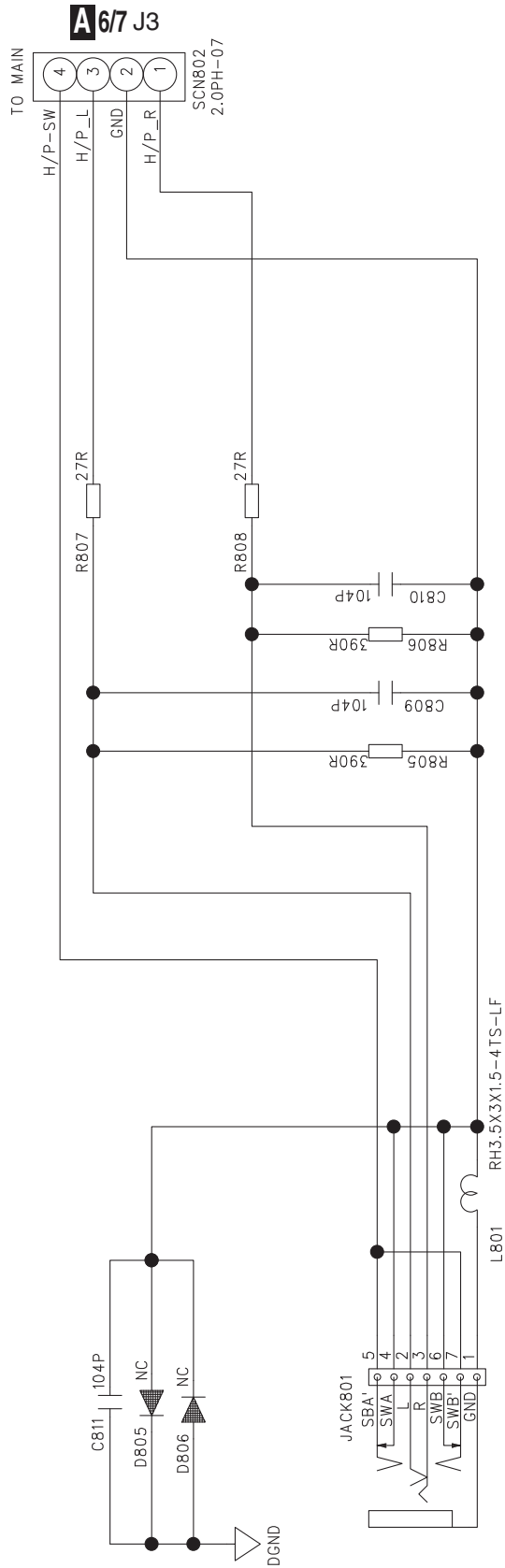

10.13 POWER PCB ASSY

1 2 3 4

A
B
C
D
E
F
G

A 3/7 J11

A 3/7 J9

G

X-HM20-K

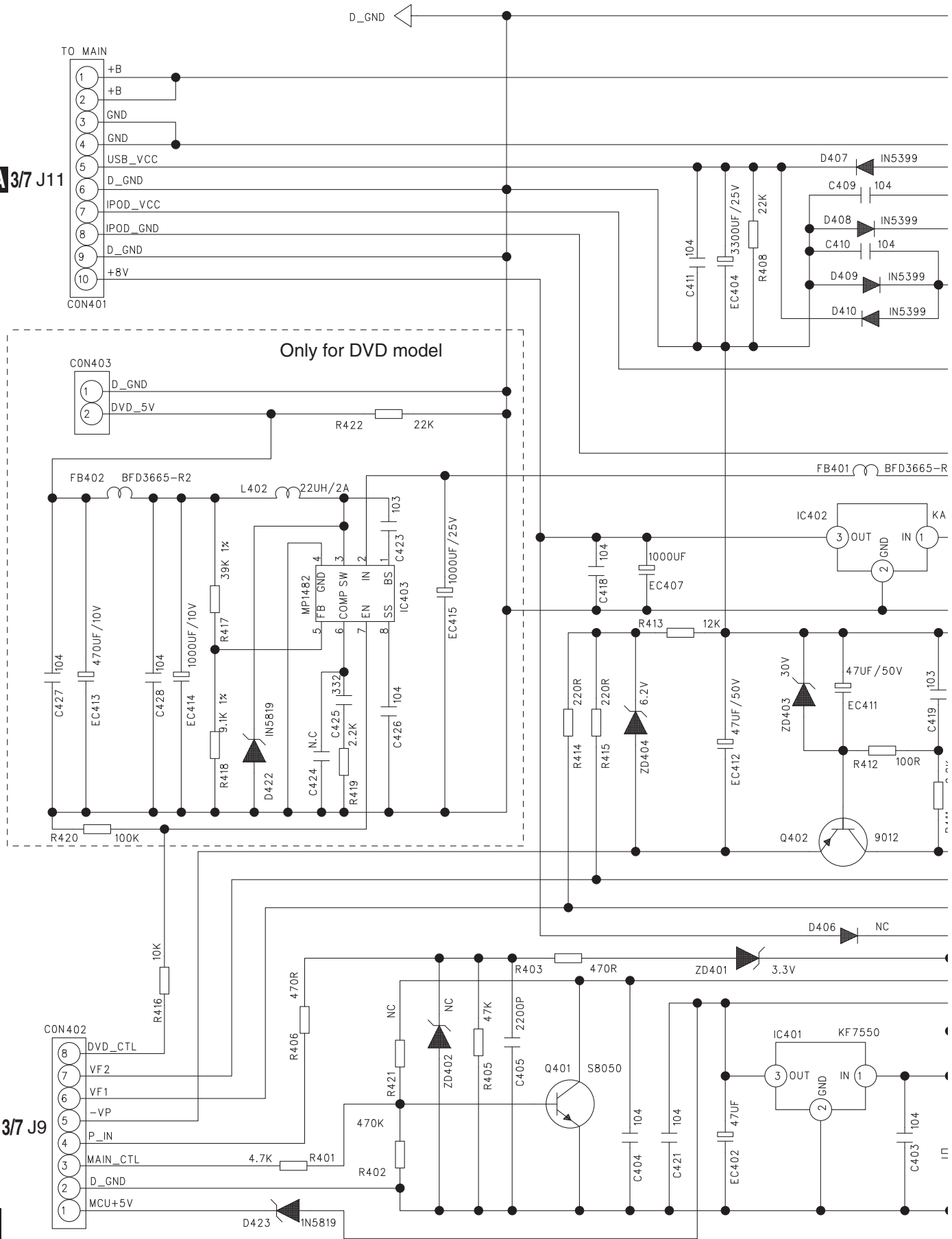

1 2 3 4

POWER PCB ASSY
(X-HM20: 92L36800201010)
(X-HM10: 92L36800101010)

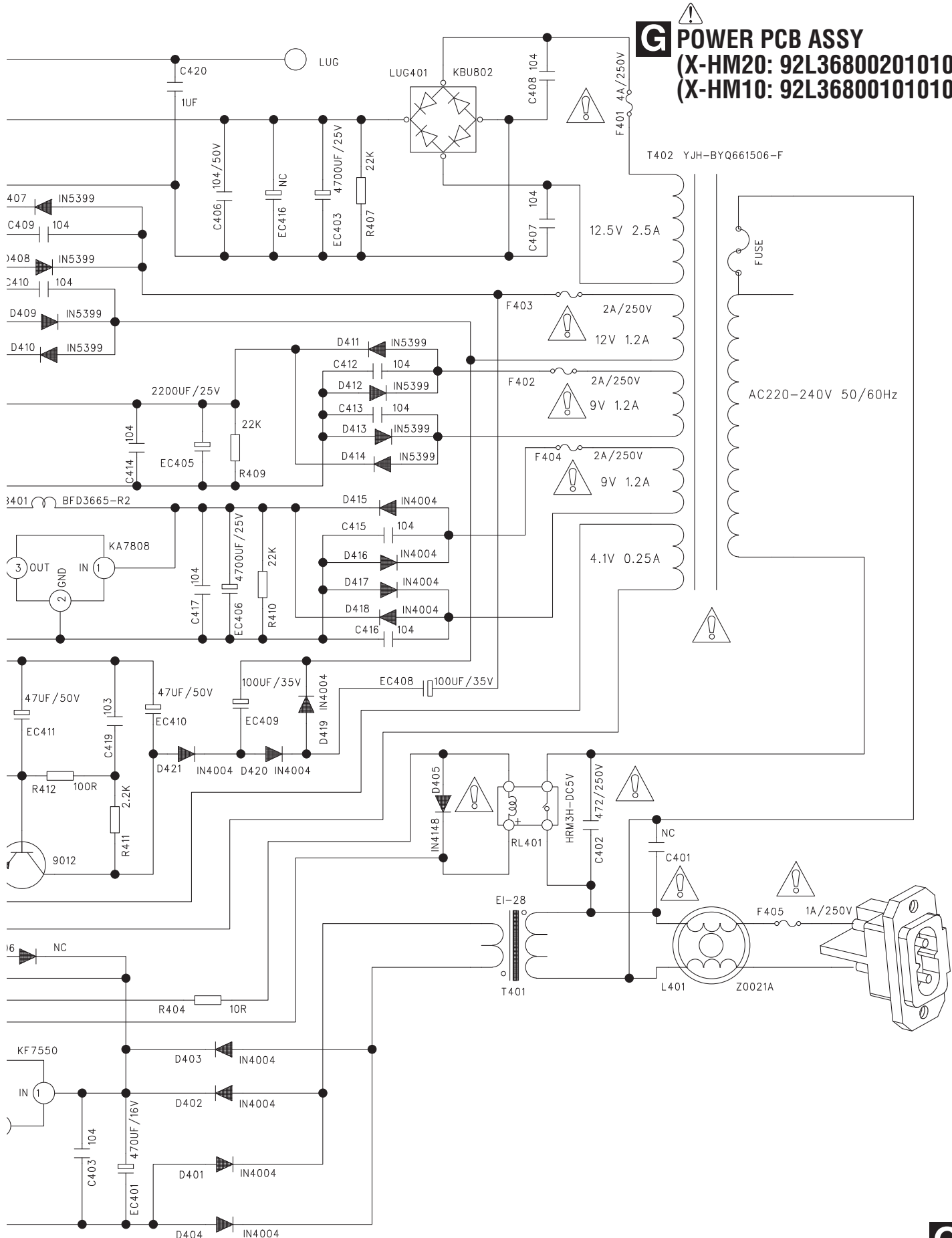

X-HM20-K



10.14 USB PCB ASSY



USB PCB ASSY

(X-HM20: 92L36900201011)

(X-HM10: 92L36900101011)

A

B

C

D

E

F

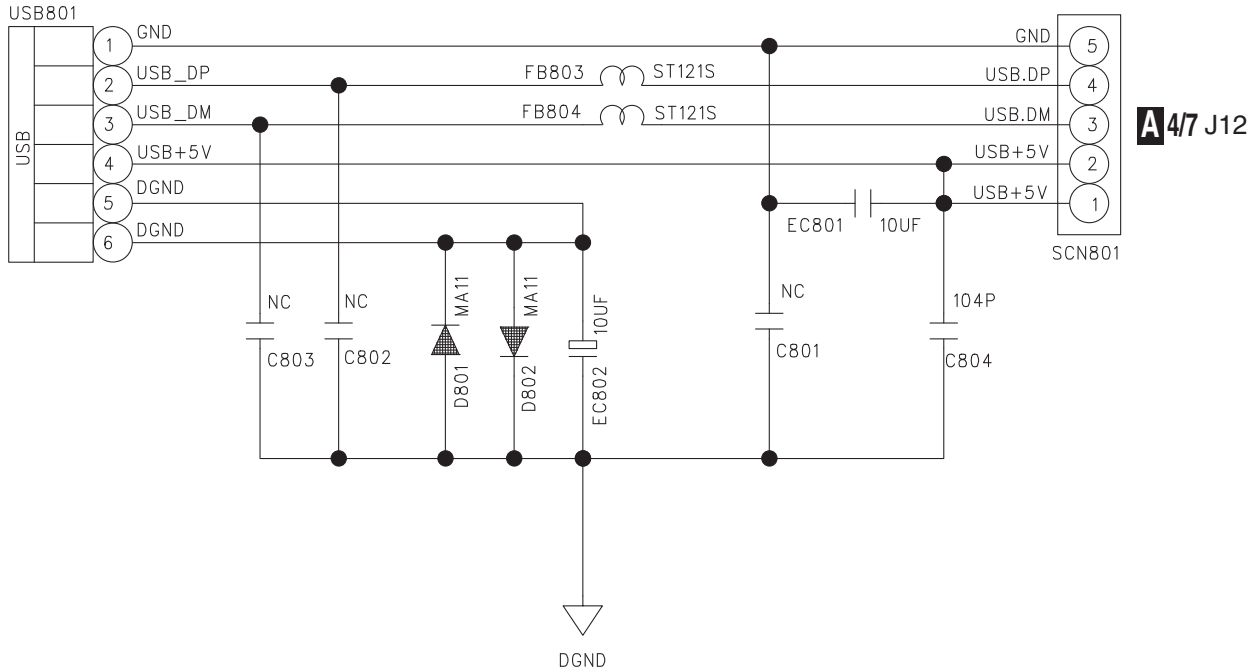

A 4/7 J12



■

5

■

6

■

7

■

8

■

A

■

B

■

C

■

D

■

E

■

F

■

5

■

6

X-HM20-K

■

7

■

8

■

11. PCB CONNECTION DIAGRAM

11.1 MAIN and IPOD PCB ASSYS

A SIDE A

A
B
C
D
E
F
A

CD MECHA
C CON702 UNIT (PICKUP)

A MAIN PCB ASSY

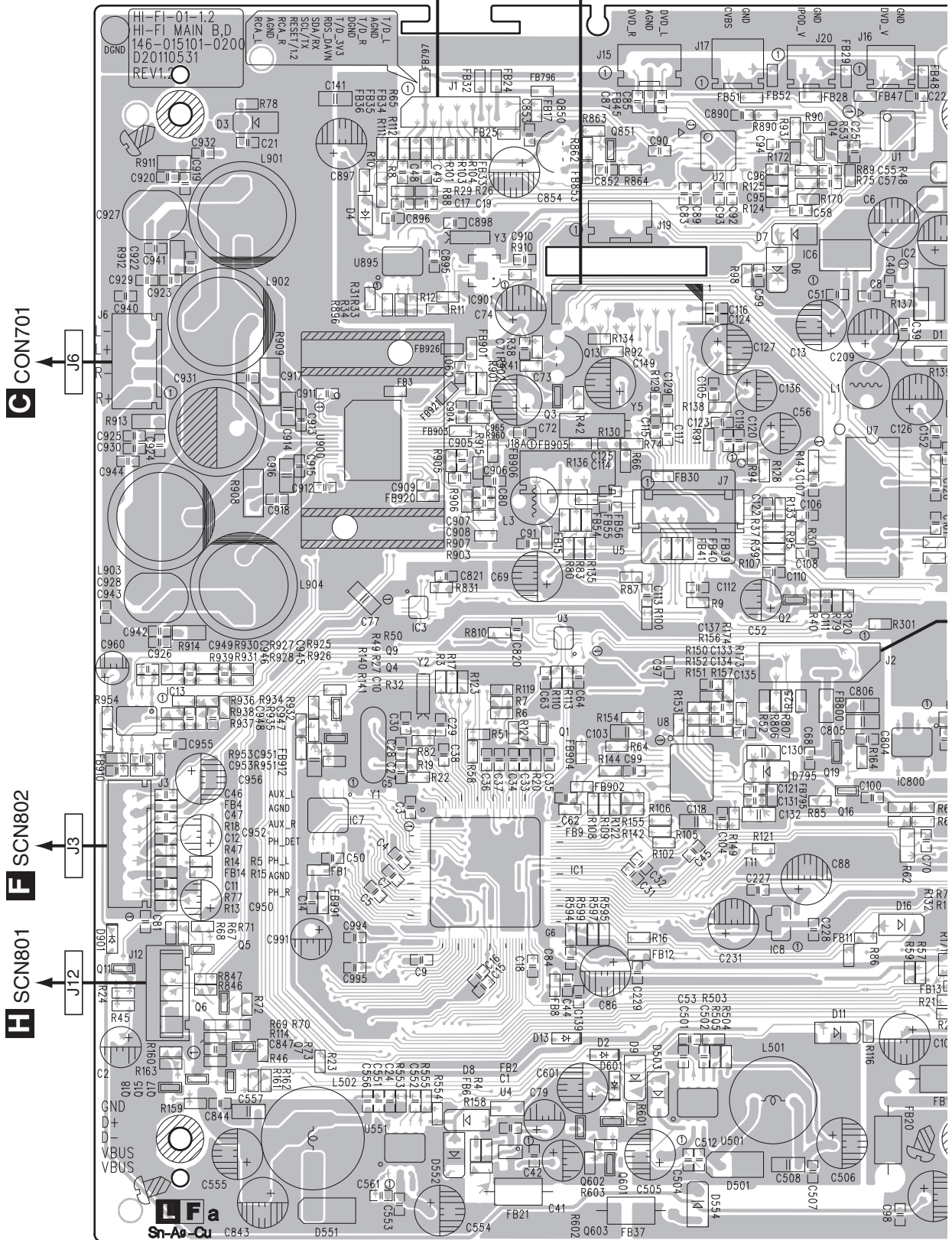

SIDE A

A

NOTE FOR PCB DIAGRAMS :

- 1. The parts mounted on this PCB include all necessary parts for several destinations. For further information for respective destinations, be sure to check with the schematic diagram.

- 2. View point of PCB diagrams.

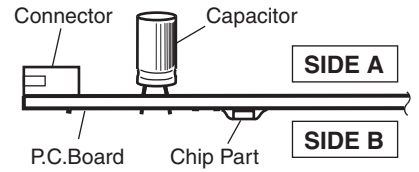

B

C

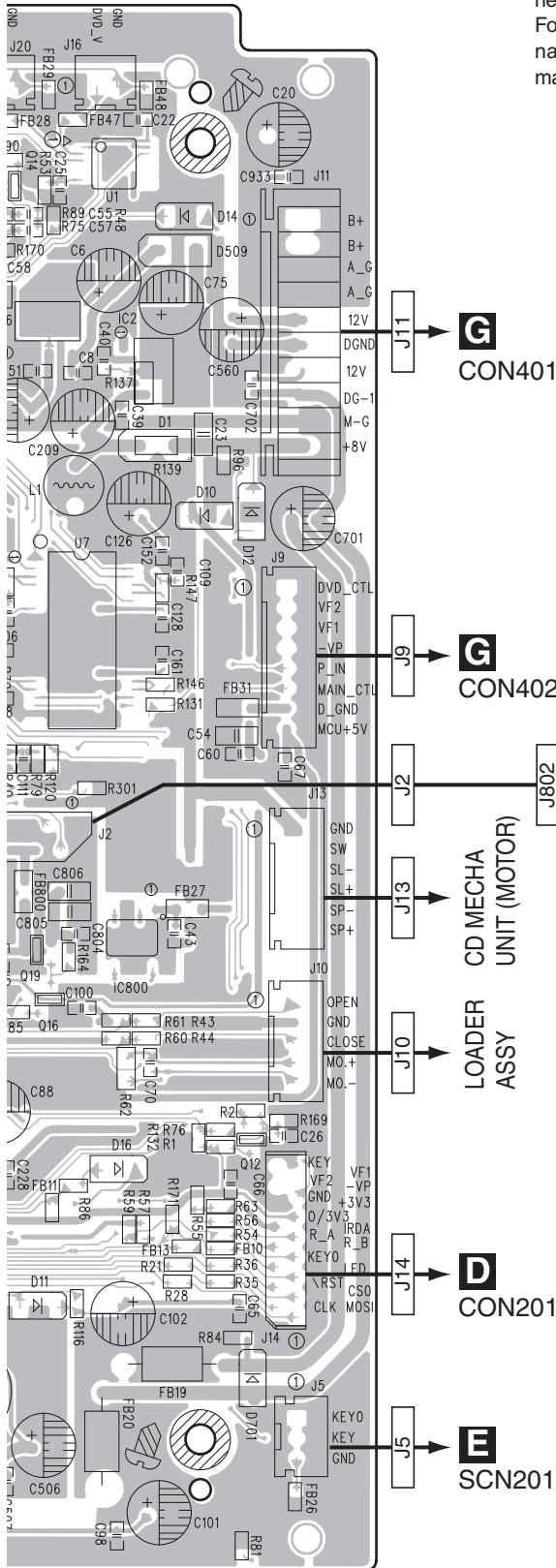

B iPod PCB ASSY

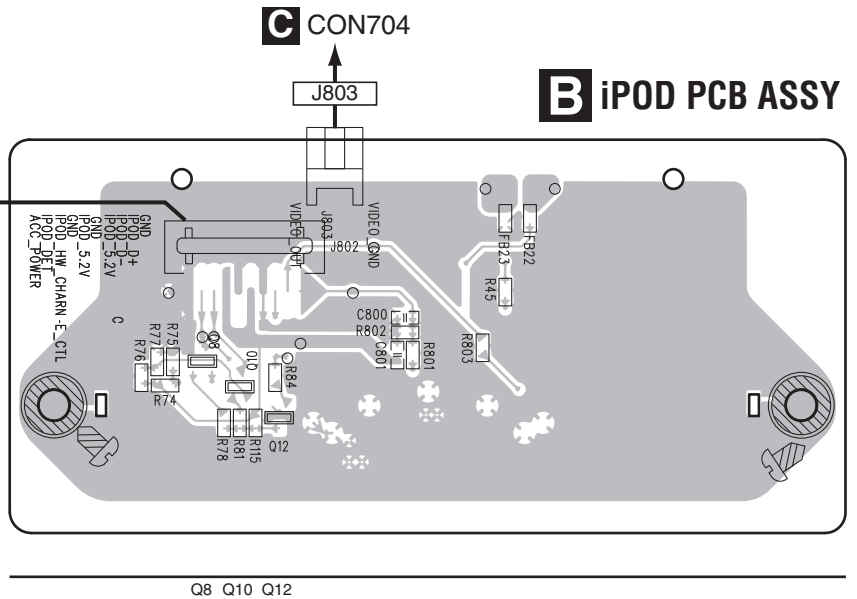

D

E

F

A B

SIDE B

A

B

C

B IPOD PCB ASSY

J803

J802

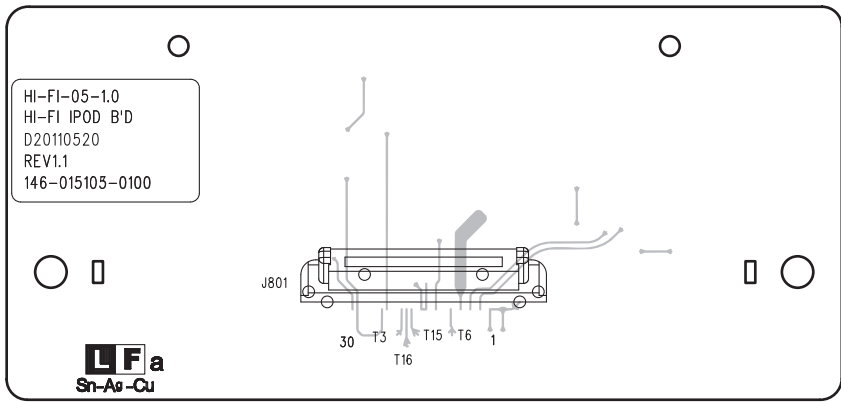

D

E

F

A MAIN PCB ASSY

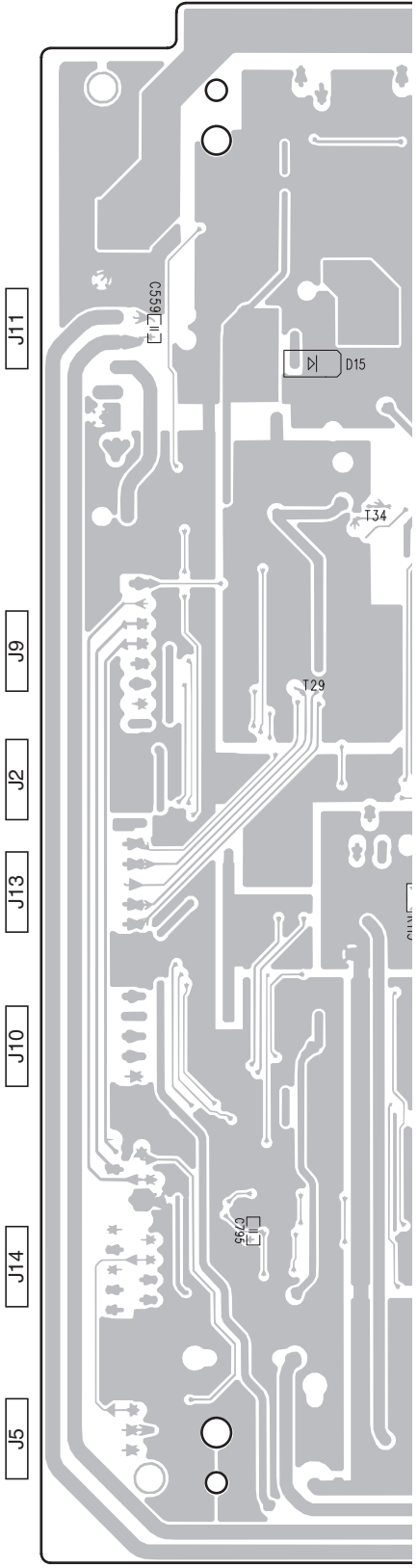

A B

SIDE B

A

B ASSY

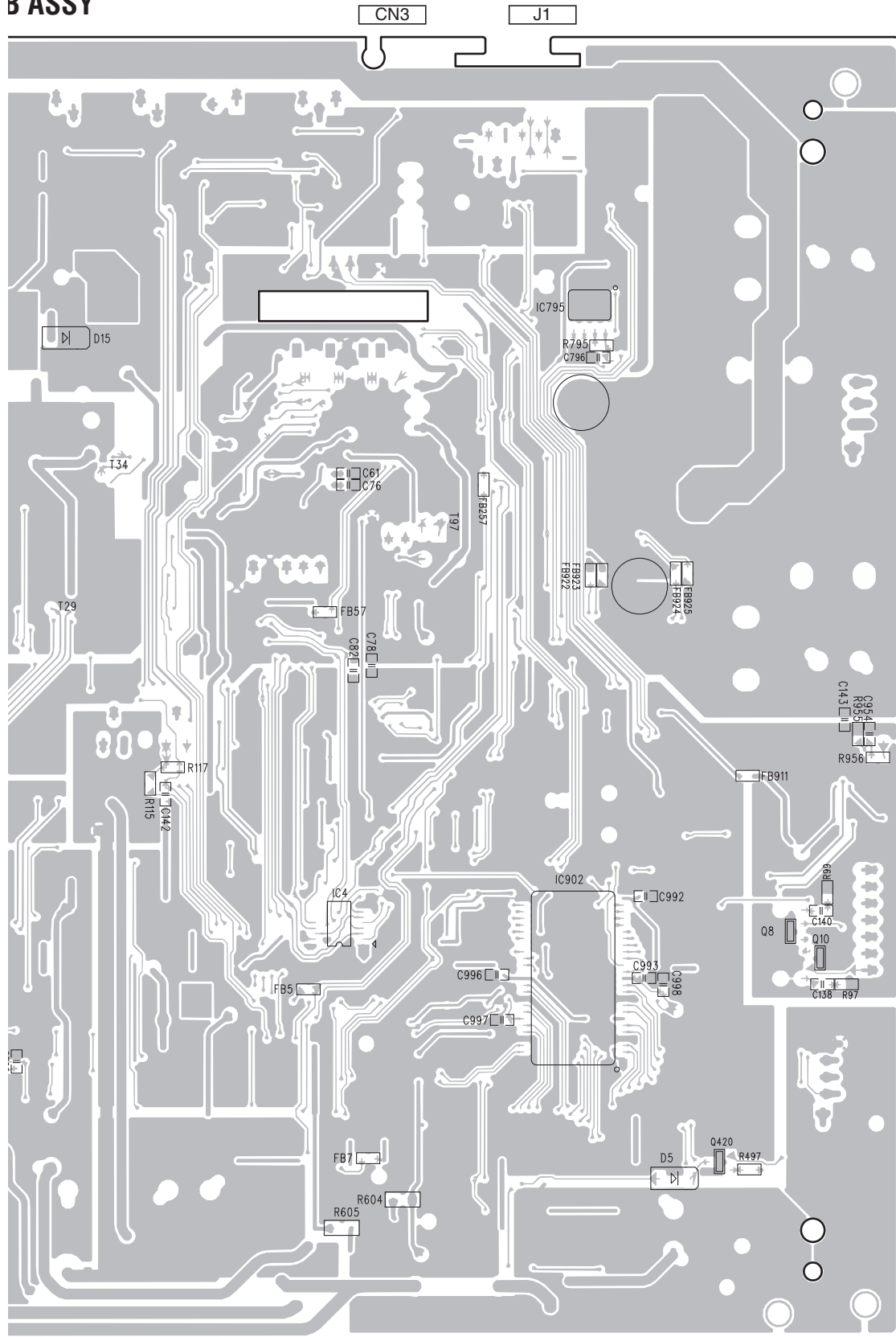

B

C

D

E

F

IC795

IC4
Q8
Q10
IC902

Q420

X-HM20-K

A

11.2 DISPLAY and KEY-SWITCH PCB ASSYS

SIDE A

Q201 IR101 IC201

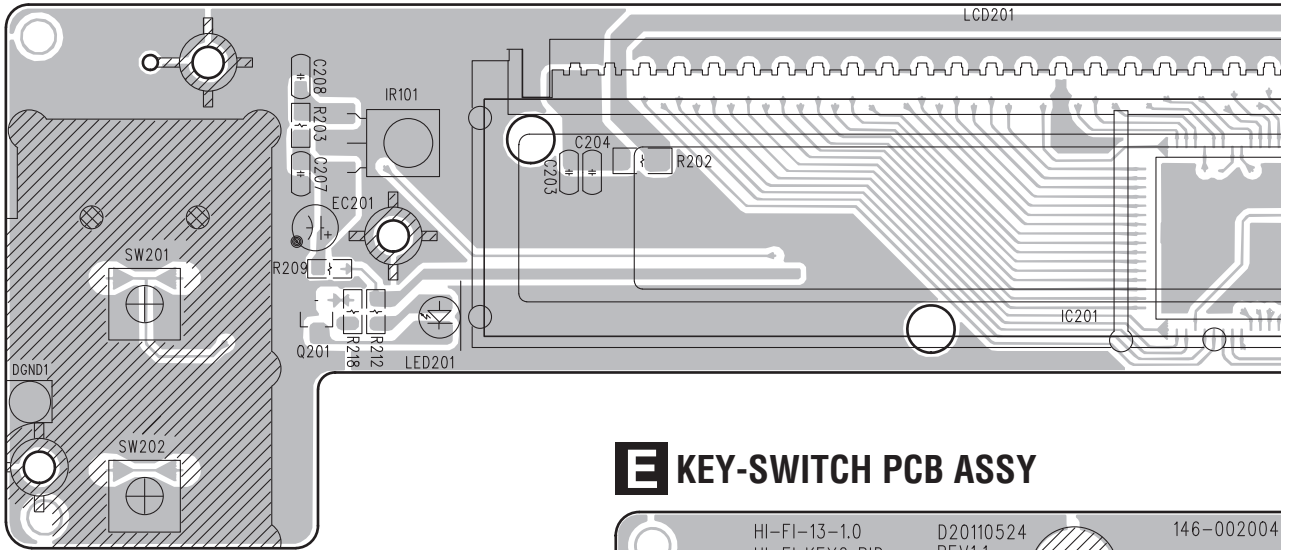

E KEY-SWITCH PCB ASSY

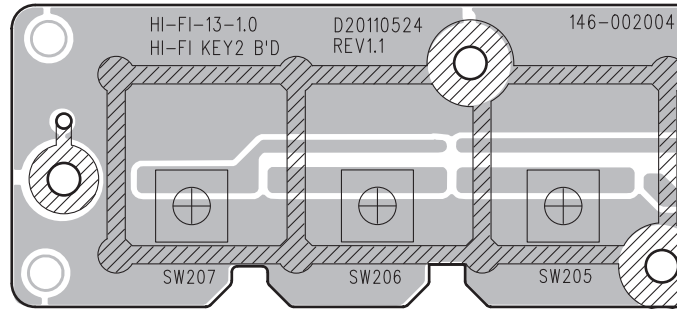

SIDE B

E KEY-SWITCH PCB ASSY

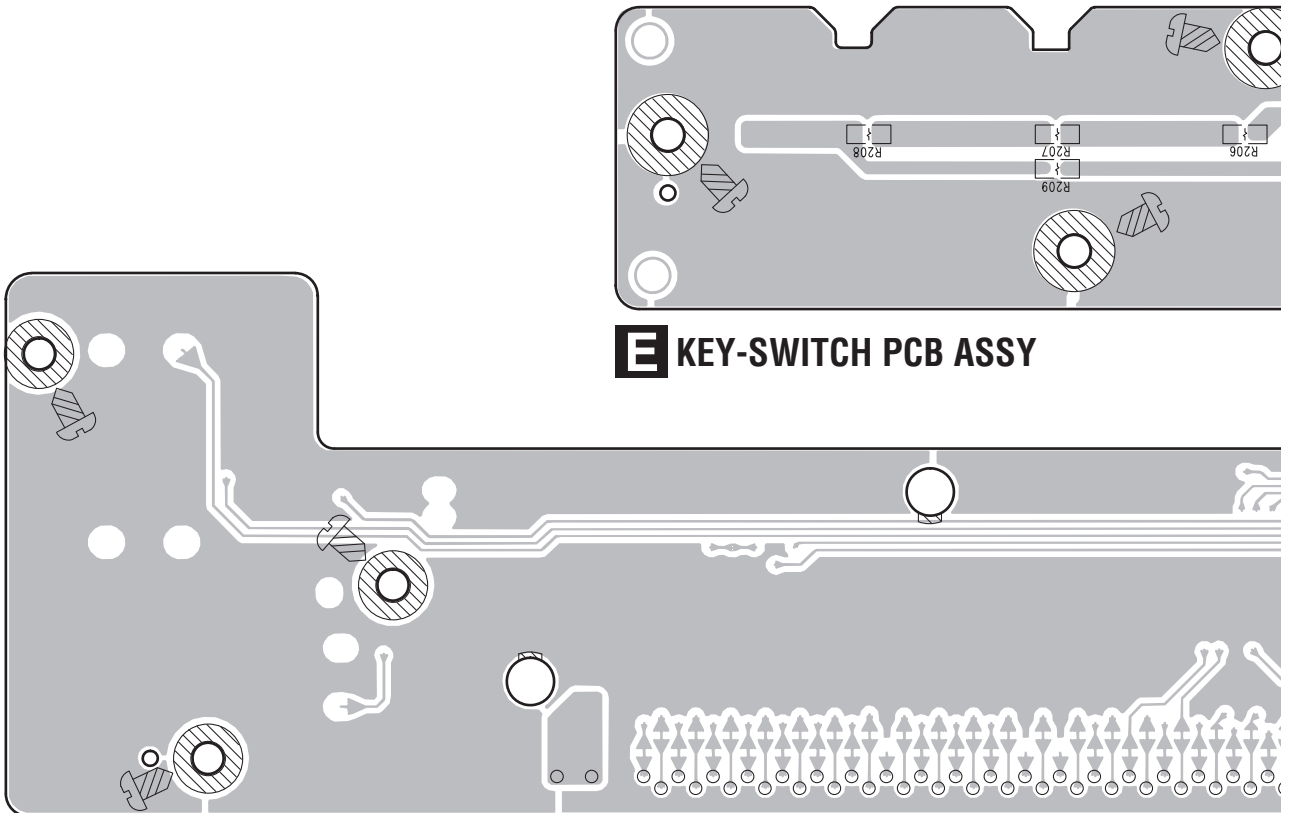

D E

IC16

D DISPLAY PCB ASSY

SIDE A

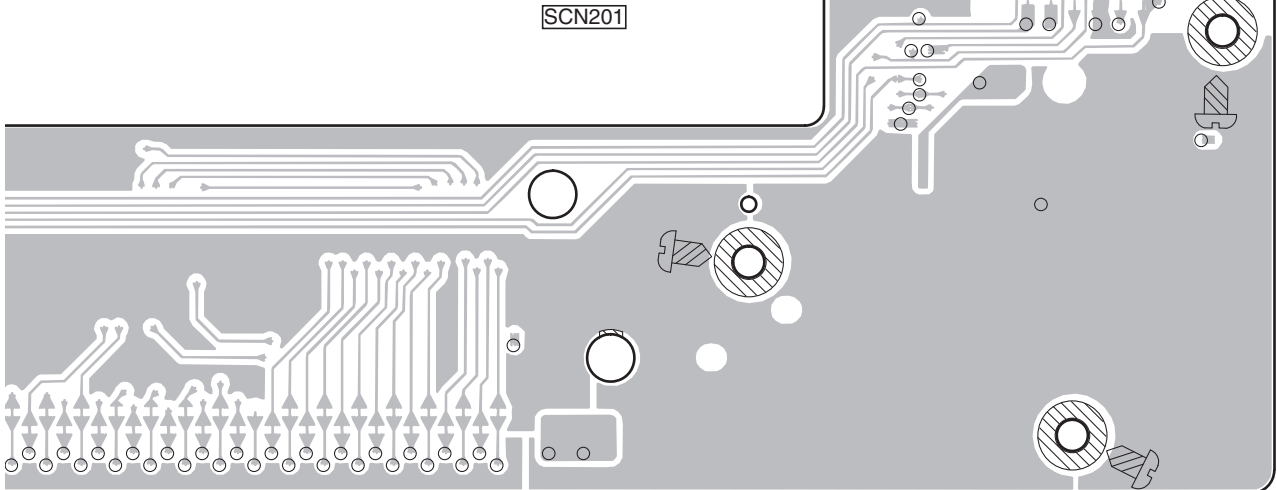
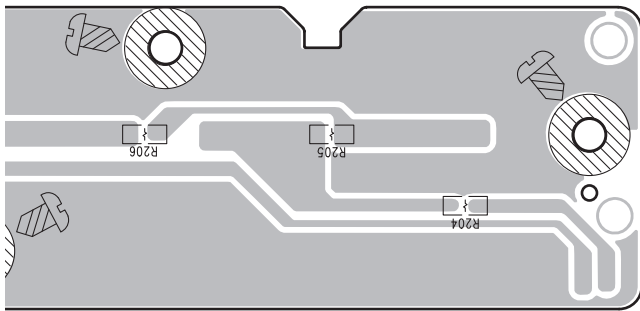
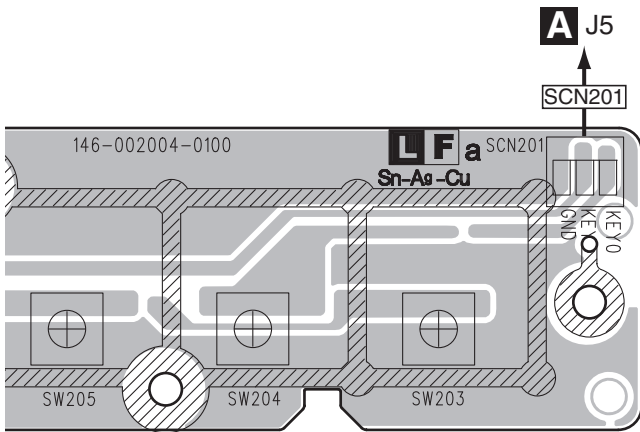
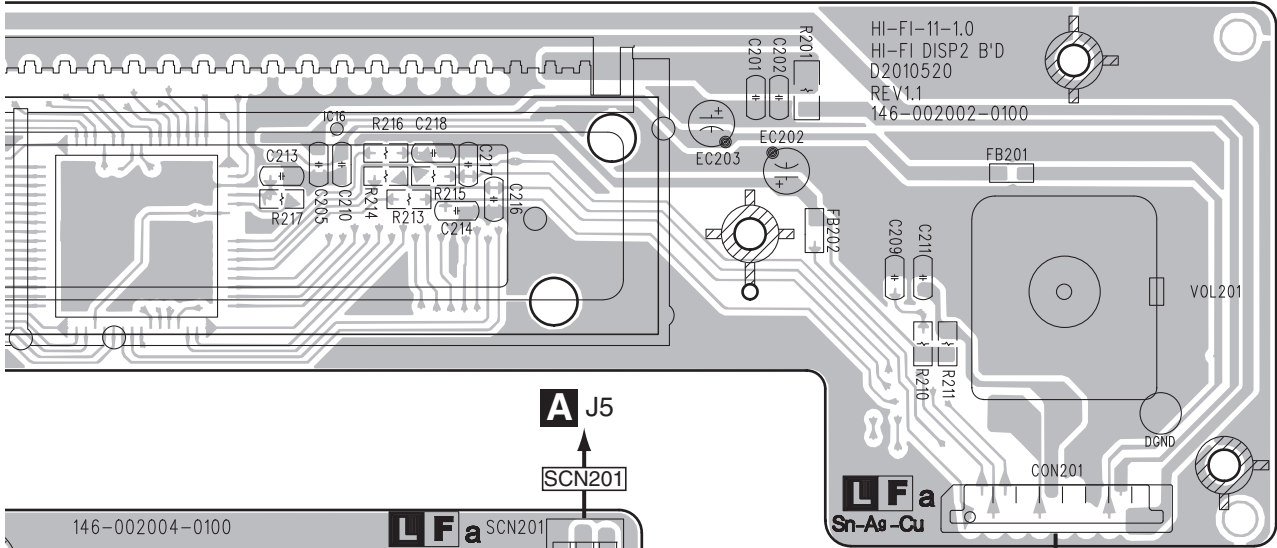

SIDE B

D DISPLAY PCB ASSY

D E

11.3 RADIO PCB ASSY

SIDE A

SIDE A

C RADIO PCB ASSY

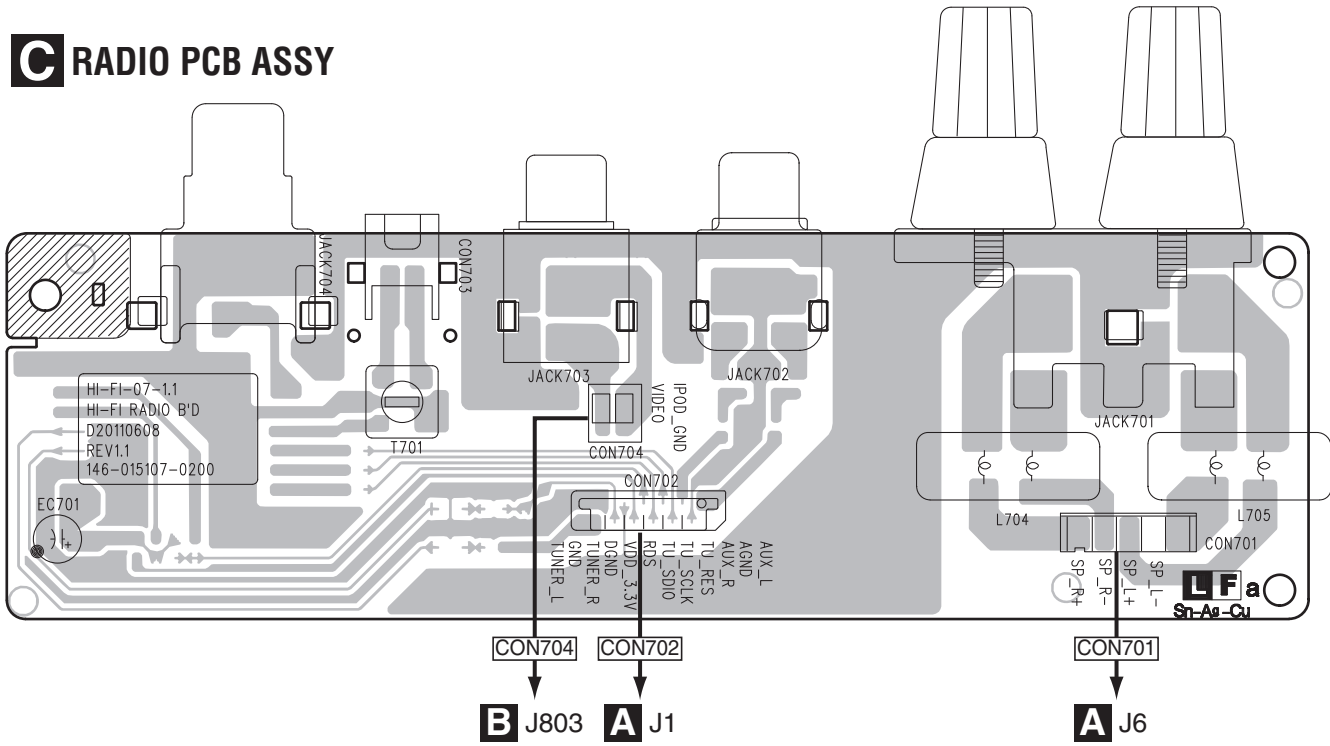

SIDE B

SIDE B

C RADIO PCB ASSY

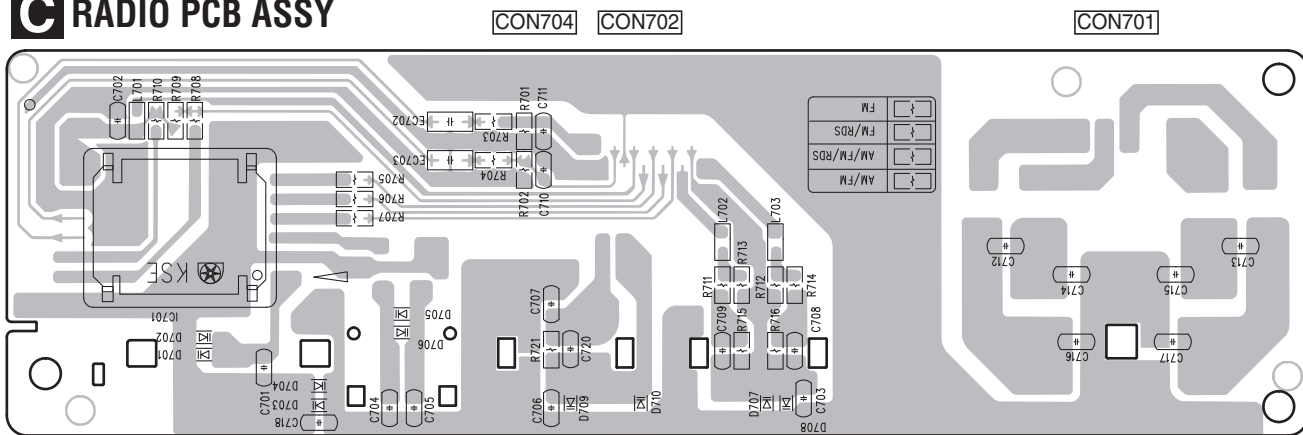

IC701

C

11.4 HEADPHONE and USB PCB ASSYS

SIDE A

F HEADPHONE PCB ASSY

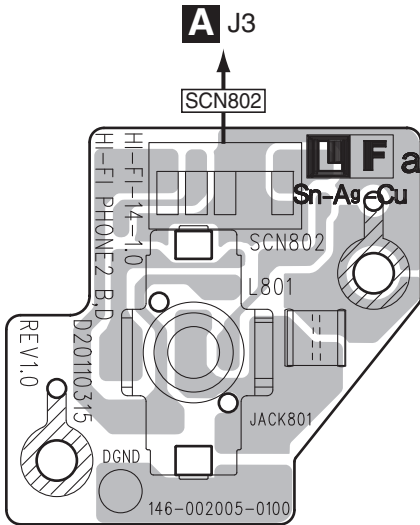

SIDE B

F HEADPHONE PCB ASSY

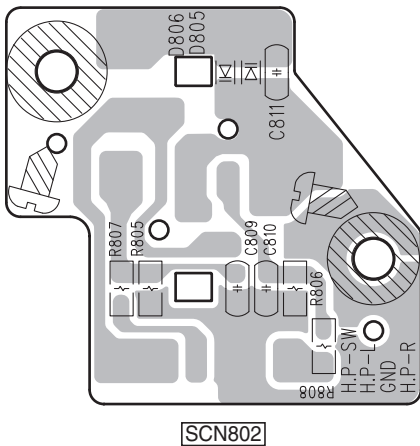

SIDE A

H USB PCB ASSY

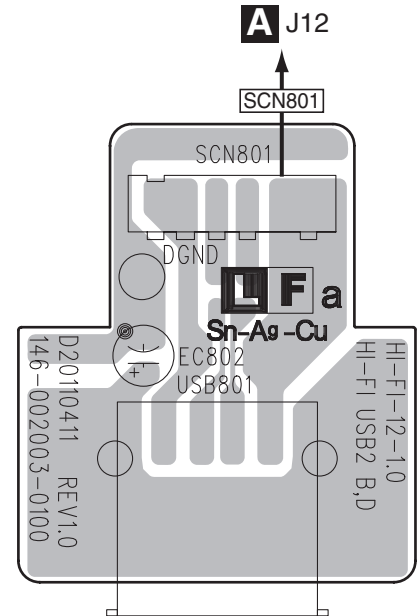

SIDE B

H USB PCB ASSY

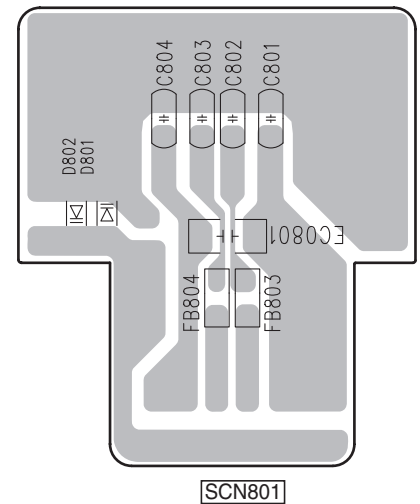

11.5 POWER PCB ASSY

SIDE A

SIDE A

A

B

C

D

E

F

AC IN

JACK401

G POWER PCB ASSY

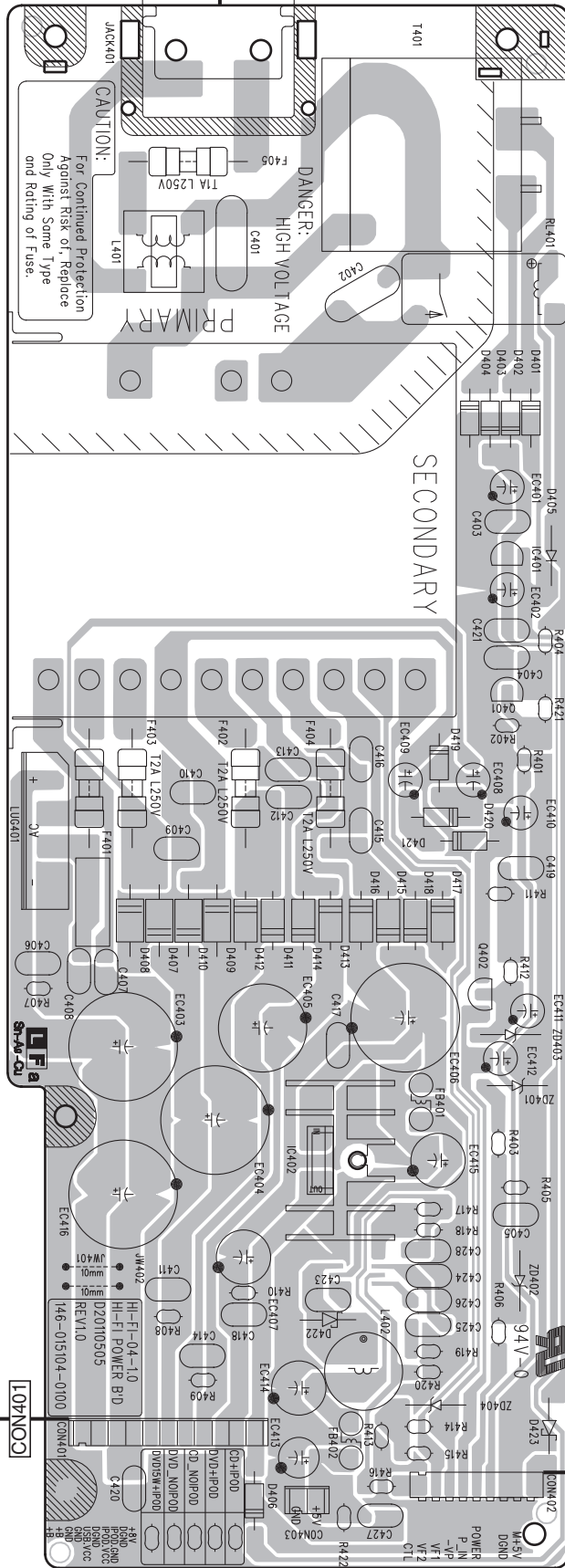

IC401

Q401

Q402

IC402

A J11

CON401

CON402

A J9



SIDE B

SIDE B

G POWER PCB ASSY JACK401

A

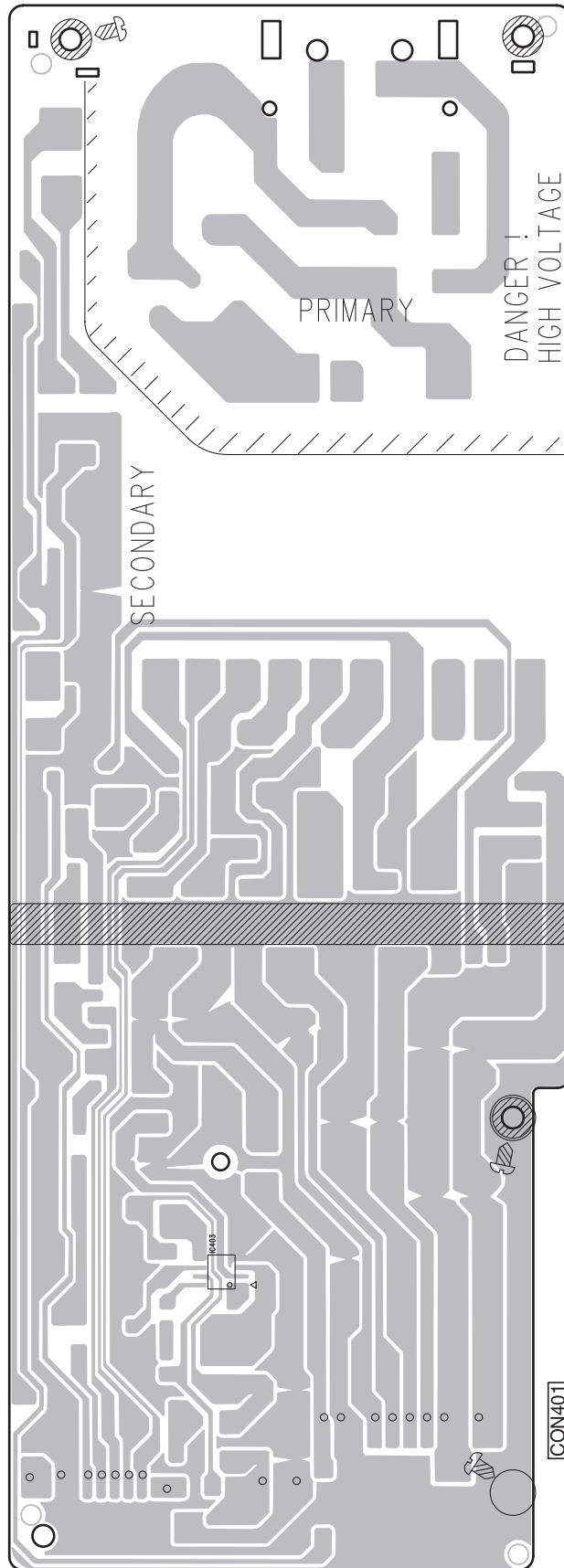

B

C

D

E

F