



LG

Life's Good

North/Latin America
Europe/Africa
Asia/Oceania

Internal Use Only

<http://aic.lgservice.com>
<http://eic.lgservice.com>
<http://biz.lgservice.com>

LED TV

SERVICE MANUAL

CHASSIS : LD55T

MODEL : 32LF56** 32LF56**-Z*

CAUTION

BEFORE SERVICING THE CHASSIS,
READ THE SAFETY PRECAUTIONS IN THIS MANUAL.

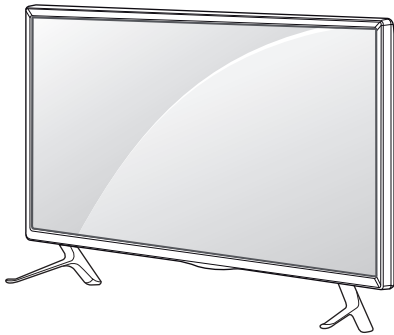

CONTENTS

CONTENTS	2
SAFETY PRECAUTIONS	3
SERVICING PRECAUTIONS	4
SPECIFICATION	6
ADJUSTMENT INSTRUCTION	11
BLOCK DIAGRAM	17
EXPLODED VIEW	21
SCHEMATIC CIRCUIT DIAGRAM	APPENDIX
TROUBLE SHOOTING GUIDE	APPENDIX

SAFETY PRECAUTIONS

IMPORTANT SAFETY NOTICE

Many electrical and mechanical parts in this chassis have special safety-related characteristics. These parts are identified by \triangle in the Schematic Diagram and Exploded View.

It is essential that these special safety parts should be replaced with the same components as recommended in this manual to prevent Shock, Fire, or other Hazards.

Do not modify the original design without permission of manufacturer.

General Guidance

An **isolation Transformer should always be used** during the servicing of a receiver whose chassis is not isolated from the AC power line. Use a transformer of adequate power rating as this protects the technician from accidents resulting in personal injury from electrical shocks.

It will also protect the receiver and its components from being damaged by accidental shorts of the circuitry that may be inadvertently introduced during the service operation.

If any fuse (or Fusible Resistor) in this TV receiver is blown, replace it with the specified.

When replacing a high wattage resistor (Oxide Metal Film Resistor, over 1 W), keep the resistor 10 mm away from PCB.

Keep wires away from high voltage or high temperature parts.

Before returning the receiver to the customer,

Always perform an **AC leakage current check** on the exposed metallic parts of the cabinet, such as antennas, terminals, etc., to be sure the set is safe to operate without damage of electrical shock.

Leakage Current Cold Check(Antenna Cold Check)

With the instrument AC plug removed from AC source, connect an electrical jumper across the two AC plug prongs. Place the AC switch in the on position, connect one lead of ohm-meter to the AC plug prongs tied together and touch other ohm-meter lead in turn to each exposed metallic parts such as antenna terminals, phone jacks, etc.

If the exposed metallic part has a return path to the chassis, the measured resistance should be between 1 M Ω and 5.2 M Ω .

When the exposed metal has no return path to the chassis the reading must be infinite.

An other abnormality exists that must be corrected before the receiver is returned to the customer.

Leakage Current Hot Check (See below Figure)

Plug the AC cord directly into the AC outlet.

Do not use a line Isolation Transformer during this check.

Connect 1.5 K / 10 watt resistor in parallel with a 0.15 uF capacitor between a known good earth ground (Water Pipe, Conduit, etc.) and the exposed metallic parts.

Measure the AC voltage across the resistor using AC voltmeter with 1000 ohms/volt or more sensitivity.

Reverse plug the AC cord into the AC outlet and repeat AC voltage measurements for each exposed metallic part. Any voltage measured must not exceed 0.75 volt RMS which corresponds to 0.5 mA.

In case any measurement is out of the limits specified, there is possibility of shock hazard and the set must be checked and repaired before it is returned to the customer.

Leakage Current Hot Check circuit

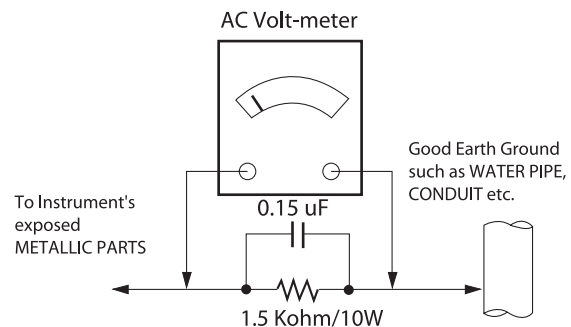

When 25A is impressed between Earth and 2nd Ground for 1 second, Resistance must be less than 0.1 Ω

*Base on Adjustment standard

SERVICING PRECAUTIONS

CAUTION: Before servicing receivers covered by this service manual and its supplements and addenda, read and follow the **SAFETY PRECAUTIONS** on page 3 of this publication.

NOTE: If unforeseen circumstances create conflict between the following servicing precautions and any of the safety precautions on page 3 of this publication, always follow the safety precautions. Remember: Safety First.

General Servicing Precautions

1. Always unplug the receiver AC power cord from the AC power source before;

- Removing or reinstalling any component, circuit board module or any other receiver assembly.
- Disconnecting or reconnecting any receiver electrical plug or other electrical connection.
- Connecting a test substitute in parallel with an electrolytic capacitor in the receiver.

CAUTION: A wrong part substitution or incorrect polarity installation of electrolytic capacitors may result in an explosion hazard.

- Test high voltage only by measuring it with an appropriate high voltage meter or other voltage measuring device (DVM, FETVOM, etc) equipped with a suitable high voltage probe. Do not test high voltage by "drawing an arc".
- Do not spray chemicals on or near this receiver or any of its assemblies.
- Unless specified otherwise in this service manual, clean electrical contacts only by applying the following mixture to the contacts with a pipe cleaner, cotton-tipped stick or comparable non-abrasive applicator; 10 % (by volume) Acetone and 90 % (by volume) isopropyl alcohol (90 % - 99 % strength)
CAUTION: This is a flammable mixture.
Unless specified otherwise in this service manual, lubrication of contacts is not required.
- Do not defeat any plug/socket B+ voltage interlocks with which receivers covered by this service manual might be equipped.
- Do not apply AC power to this instrument and/or any of its electrical assemblies unless all solid-state device heat sinks are correctly installed.
- Always connect the test receiver ground lead to the receiver chassis ground before connecting the test receiver positive lead.
Always remove the test receiver ground lead last.
- Use with this receiver only the test fixtures specified in this service manual.
CAUTION: Do not connect the test fixture ground strap to any heat sink in this receiver.

Electrostatically Sensitive (ES) Devices

Some semiconductor (solid-state) devices can be damaged easily by static electricity. Such components commonly are called Electrostatically Sensitive (ES) Devices. Examples of typical ES devices are integrated circuits and some field-effect transistors and semiconductor "chip" components. The following techniques should be used to help reduce the incidence of component damage caused by static by static electricity.

- Immediately before handling any semiconductor component or semiconductor-equipped assembly, drain off any electrostatic charge on your body by touching a known earth ground. Alternatively, obtain and wear a commercially available discharging wrist strap device, which should be removed to prevent potential shock reasons prior to applying power to the unit under test.

- After removing an electrical assembly equipped with ES devices, place the assembly on a conductive surface such as aluminum foil, to prevent electrostatic charge buildup or exposure of the assembly.
- Use only a grounded-tip soldering iron to solder or unsolder ES devices.
- Use only an anti-static type solder removal device. Some solder removal devices not classified as "anti-static" can generate electrical charges sufficient to damage ES devices.
- Do not use freon-propelled chemicals. These can generate electrical charges sufficient to damage ES devices.
- Do not remove a replacement ES device from its protective package until immediately before you are ready to install it. (Most replacement ES devices are packaged with leads electrically shorted together by conductive foam, aluminum foil or comparable conductive material).
- Immediately before removing the protective material from the leads of a replacement ES device, touch the protective material to the chassis or circuit assembly into which the device will be installed.
CAUTION: Be sure no power is applied to the chassis or circuit, and observe all other safety precautions.
- Minimize bodily motions when handling unpackaged replacement ES devices. (Otherwise harmless motion such as the brushing together of your clothes fabric or the lifting of your foot from a carpeted floor can generate static electricity sufficient to damage an ES device.)

General Soldering Guidelines

- Use a grounded-tip, low-wattage soldering iron and appropriate tip size and shape that will maintain tip temperature within the range of 500 °F to 600 °F.
- Use an appropriate gauge of RMA resin-core solder composed of 60 parts tin/40 parts lead.
- Keep the soldering iron tip clean and well tinned.
- Thoroughly clean the surfaces to be soldered. Use a mall wire-bristle (0.5 inch, or 1.25 cm) brush with a metal handle. Do not use freon-propelled spray-on cleaners.
- Use the following unsoldering technique
 - Allow the soldering iron tip to reach normal temperature. (500 °F to 600 °F)
 - Heat the component lead until the solder melts.
 - Quickly draw the melted solder with an anti-static, suction-type solder removal device or with solder braid.
CAUTION: Work quickly to avoid overheating the circuit board printed foil.
- Use the following soldering technique.
 - Allow the soldering iron tip to reach a normal temperature (500 °F to 600 °F)
 - First, hold the soldering iron tip and solder the strand against the component lead until the solder melts.
 - Quickly move the soldering iron tip to the junction of the component lead and the printed circuit foil, and hold it there only until the solder flows onto and around both the component lead and the foil.
CAUTION: Work quickly to avoid overheating the circuit board printed foil.
 - Closely inspect the solder area and remove any excess or splashed solder with a small wire-bristle brush.

IC Remove/Replacement

Some chassis circuit boards have slotted holes (oblong) through which the IC leads are inserted and then bent flat against the circuit foil. When holes are the slotted type, the following technique should be used to remove and replace the IC. When working with boards using the familiar round hole, use the standard technique as outlined in paragraphs 5 and 6 above.

Removal

1. Desolder and straighten each IC lead in one operation by gently prying up on the lead with the soldering iron tip as the solder melts.
2. Draw away the melted solder with an anti-static suction-type solder removal device (or with solder braid) before removing the IC.

Replacement

1. Carefully insert the replacement IC in the circuit board.
2. Carefully bend each IC lead against the circuit foil pad and solder it.
3. Clean the soldered areas with a small wire-bristle brush. (It is not necessary to reapply acrylic coating to the areas).

"Small-Signal" Discrete Transistor Removal/Replacement

1. Remove the defective transistor by clipping its leads as close as possible to the component body.
2. Bend into a "U" shape the end of each of three leads remaining on the circuit board.
3. Bend into a "U" shape the replacement transistor leads.
4. Connect the replacement transistor leads to the corresponding leads extending from the circuit board and crimp the "U" with long nose pliers to insure metal to metal contact then solder each connection.

Power Output, Transistor Device

Removal/Replacement

1. Heat and remove all solder from around the transistor leads.
2. Remove the heat sink mounting screw (if so equipped).
3. Carefully remove the transistor from the heat sink of the circuit board.
4. Insert new transistor in the circuit board.
5. Solder each transistor lead, and clip off excess lead.
6. Replace heat sink.

Diode Removal/Replacement

1. Remove defective diode by clipping its leads as close as possible to diode body.
2. Bend the two remaining leads perpendicular y to the circuit board.
3. Observing diode polarity, wrap each lead of the new diode around the corresponding lead on the circuit board.
4. Securely crimp each connection and solder it.
5. Inspect (on the circuit board copper side) the solder joints of the two "original" leads. If they are not shiny, reheat them and if necessary, apply additional solder.

Fuse and Conventional Resistor

Removal/Replacement

1. Clip each fuse or resistor lead at top of the circuit board hollow stake.
2. Securely crimp the leads of replacement component around notch at stake top.

3. Solder the connections.

CAUTION: Maintain original spacing between the replaced component and adjacent components and the circuit board to prevent excessive component temperatures.

Circuit Board Foil Repair

Excessive heat applied to the copper foil of any printed circuit board will weaken the adhesive that bonds the foil to the circuit board causing the foil to separate from or "lift-off" the board. The following guidelines and procedures should be followed whenever this condition is encountered.

At IC Connections

To repair a defective copper pattern at IC connections use the following procedure to install a jumper wire on the copper pattern side of the circuit board. (Use this technique only on IC connections).

1. Carefully remove the damaged copper pattern with a sharp knife. (Remove only as much copper as absolutely necessary).
2. Carefully scratch away the solder resist and acrylic coating (if used) from the end of the remaining copper pattern.
3. Bend a small "U" in one end of a small gauge jumper wire and carefully crimp it around the IC pin. Solder the IC connection.
4. Route the jumper wire along the path of the out-away copper pattern and let it overlap the previously scraped end of the good copper pattern. Solder the overlapped area and clip off any excess jumper wire.

At Other Connections

Use the following technique to repair the defective copper pattern at connections other than IC Pins. This technique involves the installation of a jumper wire on the component side of the circuit board.

1. Remove the defective copper pattern with a sharp knife. Remove at least 1/4 inch of copper, to ensure that a hazardous condition will not exist if the jumper wire opens.
2. Trace along the copper pattern from both sides of the pattern break and locate the nearest component that is directly connected to the affected copper pattern.
3. Connect insulated 20-gauge jumper wire from the lead of the nearest component on one side of the pattern break to the lead of the nearest component on the other side. Carefully crimp and solder the connections.

CAUTION: Be sure the insulated jumper wire is dressed so the it does not touch components or sharp edges.

SPECIFICATION

NOTE : Specifications and others are subject to change without notice for improvement.

1. Application range

This specification is applied to the LED TV used LD55T chassis.

2. Requirement for Test

Each part is tested as below without special appointment.

- 1) Temperature: 25 °C ± 5 °C(77 °F ± 9 °F), CST: 40 °C ± 5 °C
- 2) Relative Humidity: 65 % ± 10 %
- 3) Power Voltage
: Standard input voltage (AC 100-240 V~, 50/60 Hz)
* Standard Voltage of each products is marked by models.
- 4) Specification and performance of each parts are followed each drawing and specification by part number in accordance with BOM.
- 5) The receiver must be operated for about 5 minutes prior to the adjustment.

3. Test method

- 1) Performance: LGE TV test method followed
- 2) Demanded other specification
 - Safety : CE, IEC specification
 - EMC : CE, IEC specification

4. Model General Specification

No.	Item	Specification	Remarks
1	Market	EU(PAL Market-37Countries)	<p>DTV & Analog (Total 37 countries) DTV (MPEG2/4, DVB-T) :37 countries UK/Italy/Germany/France/Spain/Sweden/Finland/Netherlands/ Belgium/Luxemburg/ Greece/Denmark/Czech/Austria /Hungary/Swiss/Croatia/TurkeyNorway/Slovenia/Poland/Ukraine/Portugal/Ireland/Morocco/Latvia/Estonia/Lithania/Rumania/Bulgaria/Russia/SlovakiaBosnia/Serbia/Albania/Kazakhstan/Belarus</p> <p>DTV (MPEG2/4, DVB-T2): 8 countries UK/Denmark/Sweden/Finland/Norway/Ireland/Ukraine/Kazakhstan</p> <p>DTV (MPEG2/4, DVB-C): 37 countries UK/Italy/Germany/France/Spain/Sweden/Finland/Netherlands/ Belgium/Luxemburg/ Greece/Denmark/Czech/Austria /Hungary/Swiss/Croatia/TurkeyNorway/Slovenia/Poland /Ukraine/Portugal/Ireland/Morocco/Latvia/Estonia/Lithania/Rumania/Bulgaria/Russia/SlovakiaBosnia/Serbia/Albania/Kazakhstan/Belarus</p> <p>DTV (MPEG2/4,DVB-S): 29 countries Italy/Germany/France/Spain/Netherlands/ Belgium/Luxemburg/Greece/Czech/Austria /Hungary/Swiss/Croatia/Turkey/Slovenia/Poland/Portugal/ Morocco/Latvia/Estonia/Lithania/Rumania/Bulgaria/Russia/Slovakia/Bosnia/Serbia/Albania/Belarus</p> <p>Supported satellite : 22 satellites HISPASAT 1C/1D, ATLANTIC BIRD 2, NILESAT 101/102, ATLANTIC BIRD 3, AMOS 2/3, THOR 5/6, IRIUS 4, EUTELSAT-W3A, EUROBIRD 9A, EUTELSAT-W2A, HOTBIRD 6/8/9, EUTELSAT-SESAT, ASTRA 1L/H/M/KR, ASTRA 3A/3B, BADR 4/6, ASTRA 2D, EUROBIRD 3, EUTELSAT-W7, HELLASSAT 2, EXPRESS AM1, TURK-SAT 2A/3A, INTERSAT10</p>

No.	Item	Specification	Remarks
2	Broadcasting system	<p>Analogue TV 1) PAL-B/G/D/K/I 2) SECAM-B/G/D/K/I, SECAM L/L'</p> <p>Digital TV 1) DVB-T 2) DVB-C</p> <p>Satellite Digital TV 1) DVB-T/T2 2) DVB-C 3) DVB-S/S2</p>	<p>Analogue TV : (RF) VHF: E2 to E12, UHF : E21 to E69 (CATV) S1 to S20, HYPER: S21 to S47</p> <p>Digital TV : VHF, UHF</p> <p>Satellite TV : VHF, UHF, C-Band, Ku-Band</p>
3	Receiving system	<p>Analog : Upper Heterodyne Digital : COFDM, QAM</p>	<p>► DVB-T - Guard Interval(Bitrate_Mbit/s) : 1/4, 1/8, 1/16, 1/32 - Modulation : Code Rate QPSK : 1/2, 2/3, 3/4, 5/6, 7/8 16-QAM : 1/2, 2/3, 3/4, 5/6, 7/8 64-QAM : 1/2, 2/3, 3/4, 5/6, 7/8</p> <p>► DVB-T2 - Guard Interval(Bitrate_Mbit/s) : 1/4, 1/8, 1/16, 1/32, 1/128, 19/128, 19/256, - Modulation : Code Rate QPSK : 1/2, 2/5, 2/3, 3/4, 5/6 16-QAM : 1/2, 2/5, 2/3, 3/4, 5/6 64-QAM : 1/2, 2/5, 2/3, 3/4, 5/6 256-QAM : 1/2, 2/5, 2/3, 3/4, 5/6</p> <p>► DVB-C - Symbolrate : 4.0Msymbols/s to 7.2Msymbols/s - Modulation : 16QAM, 64-QAM, 128-QAM and 256-QAM</p> <p>► DVB-S/S2 - symbolrate DVB-S2 (8PSK / QPSK) : 2 ~ 45Msymbol/s DVB-S (QPSK) : 2 ~ 45Msymbol/s - viterbi DVB-S mode : 1/2, 2/3, 3/4, 5/6, 7/8 DVB-S2 mode : 1/2, 2/3, 3/4, 3/5, 4/5, 5/6, 8/9, 9/10</p>
4	Scart Jack (1EA)	PAL, SECAM	Scart 1 Jack is Full scart and support RF-OUT(analog). EU only
5	Component & AV Common port (1EA)	Video Input RCA (PAL, SECAM, NTSC) Component Input (Y/Cb/Cr, Y/Pb/Pr)	4 System : PAL, SECAM, NTSC, PAL60
6	HDMI Input (2EA)	HDMI1/2-DTV	Support HDCP
7	Audio Input (1EA)	Component & AV	Component & AV's audio input is used by common port.
8	SDPIF out (1EA)	SPDIF out	LF62/LF57/LF56/LF55 Series
9	Earphone out (1EA)	Antenna, AV1, AV2, Component, HDMI1, HDMI2, USB	LF62/LF57/LF56 Series
10	USB (1EA)	EMF, DivX HD, For SVC (download)	JPEG, MP3, DivX HD
11	DVB	DVB-T	CI : UK, Finland, Denmark, Norway, Sweden, Russia, Spain, Ireland, Luxemburg, Belgium, Netherland CI+ : France(Canal+), Italy(DGTVi)
		DVB-C	CI : Switzerland, Austria, Slovenia, Hungary, Bulgaria CI+ : Switzerland(UPC,Cablecom), Netherland(Ziggo), Germany(KDG,CWB), Finland(labwise)
		DVB-S	CI + : Germany(Astra HD+)
12	Ethernet (1EA)	DLNA(Wired, DMP only)	Only UK T2 Model (LF57/LF56/LF55/LF54) : for MHEG

5. Video resolutions (2D)

5.1. Component Input (Y, C_B/P_B, C_R/P_R)

No.	Resolution	H-freq(kHz)	V-freq(Hz)	Pixel clock(MHz)	Proposed
1	720*576	15.625	50.00	13.5	SDTV ,DVD 576i
2	720*480	15.73	60.00	13.5135	SDTV ,DVD 480i
3	720*480	15.73	59.94	13.50	SDTV ,DVD 480i
4	720*576	31.25	50.00	27.00	SDTV 576P
5	720*480	31.50	60.00	27.027	SDTV 480P
6	720*480	31.47	59.94	27.00	SDTV 480P
7	1280*720	37.50	50.00	74.25	HDTV 720P
8	1280*720	45.00	60.00	74.25	HDTV 720P
9	1280*720	44.96	59.94	74.176	HDTV 720P
10	1920*1080	28.12	50.00	74.25	HDTV 1080i
11	1920*1080	33.75	60.00	74.25	HDTV 1080i
12	1920*1080	33.72	59.94	74.176	HDTV 1080i
13	1920*1080	56.25	50.00	148.50	HDTV 1080P
14	1920*1080	67.50	60.00	148.50	HDTV 1080P
15	1920*1080	67.43	59.94	148.352	HDTV 1080P
16	1920*1080	27.00	24.00	74.25	HDTV 1080P
17	1920*1080	26.97	23.94	74.176	HDTV 1080P
18	1920*1080	33.75	30.00	74.25	HDTV 1080P
19	1920*1080	33.71	29.97	74.176	HDTV 1080P

5.2. HDMI Input(PC/DTV)

No.	Resolution	H-freq(kHz)	V-freq.(Hz)	Pixel clock(MHz)	Proposed		Remark
PC(DVI)					DDC		
1	640*350	31.468	70.09	25.17	EGA	X	
2	720*400	31.469	70.08	28.32	DOS	O	
3	640*480	31.469	59.94	25.17	VESA(VGA)	O	
4	800*600	37.879	60.31	40.00	VESA(SVGA)	O	
5	1024*768	48.363	60.00	65.00	VESA(XGA)	O	
6	1152*864	54.348	60.053	80.00	VESA	O	
7	1360*768	47.712	60.015	85.50	VESA (WXGA)	O	
8	1280*1024	63.981	60.020	108.0	VESA (SXGA)	O	FHD only
9	1920*1080	67.50	60.00	148.5	HDTV 1080P	O	FHD only
DTV							
1	640*480	31.46	59.94	25.125	SDTV 480P		
2	640*480	31.50	60.00	25.125	SDTV 480P		
3	720*480	31.47	59.94	27.00	SDTV 480P		
4	720*480	31.50	60.00	27.027	SDTV 480P		
5	720*576	31.25	50.00	27.00	SDTV 576P(DVB)		
6	1280*720	37.50	50.00	74.25	HDTV 720P(DVB)		
7	1280*720	45.00	60.00	74.25	HDTV 720P		
8	1280*720	44.96	59.94	74.176	HDTV 720P		
9	1920*1080	28.12	50.00	74.25	HDTV 1080I(DVB)		
10	1920*1080	33.75	60.00	74.25	HDTV 1080I		
11	1920*1080	33.72	59.94	74.176	HDTV 1080I		
12	1920*1080	56.25	50.00	148.50	HDTV 1080P(DVB)		
13	1920*1080	67.50	60.00	148.50	HDTV 1080P		
14	1920*1080	67.43	59.94	148.35	HDTV 1080P		
15	1920*1080	27.00	24.00	74.25	HDTV 1080P		
16	1920*1080	26.97	23.97	74.175	HDTV 1080P		
17	1920*1080	33.75	30.00	74.25	HDTV 1080P		
18	1920*1080	33.71	29.97	74.175	HDTV 1080P		

6. Video resolutions (3D)

6.1. HDMI Input

No.	Resolution	H-freq(kHz)	V-freq(Hz)	Pixel clock(MHz)	Proposed	3D input proposed mode
1	1280*720	37.50	50	74.25	HDTV 720P	Side by Side(half), Top and Bottom,
2	1280*720	45	60	74.25	HDTV 720P	Side by Side(half), Top and Bottom,
3	1280*720	75	50	148.5	HDTV 720P	Frame packing
4	1280*720	89.90 / 90	59.94 / 60	148.35/148.5	HDTV 720P	Frame packing
5	1920*1080	28.12	50	74.25	HDTV 1080i	Side by Side(half), Top and Bottom
6	1920*1080	33.70	60	74.25	HDTV 1080i	Side by Side(half), Top and Bottom
7	1920*1080	27.00	24	74.25	HDTV 1080P	Side by Side(half), Top and Bottom,
8	1920*1080	33.70	30	89.1	HDTV 1080P	Side by Side(half), Top and Bottom
9	1920*1080	53.95 / 54	23.98 / 24	148.35/148.5	HDTV 1080P	Frame packing
10	1920*1080	56.30	50	148.5	HDTV 1080P	Side by Side(half), Top and bottom, Single frame sequential
11	1920*1080	67.50	60	148.5	HDTV 1080P	Side by Side(half), Top and bottom, Single frame sequential



6.2. DTV Input

No.	Resolution	H-freq(kHz)	V-freq.(Hz)	Pixel clock(MHz)	Proposed	3D input proposed mode
1.	1280*720	37.500	50	74.25	HDTV 720P	Side by Side, Top & Bottom
2.	1920*1080	28.125	50	74.25	HDTV 1080I	Side by Side, Top & Bottom

6.3. USB Input

No.	Resolution	H-freq(kHz)	V-freq.(Hz)	Pixel clock(MHz)	Proposed	3D input proposed mode
1.	1920*1080	33.75	30	74.25	HDTV 1080P	Side by Side, Top & Bottom,JPS, MPO(Photo)

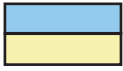
6.4. 3D Input mode

No.	Side by Side	Top & Bottom	Single Frame Sequential	Frame Packing
1				

ADJUSTMENT INSTRUCTION

1. Application Range

This specification sheet is applied to all of the LED TV with LD55T chassis.

2. Designation

- (1) The adjustment is according to the order which is designated and which must be followed, according to the plan which can be changed only on agreeing.
- (2) Power adjustment : Free Voltage.
- (3) Magnetic Field Condition: Nil.
- (4) Input signal Unit: Product Specification Standard.
- (5) Reserve after operation : Above 5 Minutes (Heat Run)
Temperature : at 25 °C ± 5 °C
Relative humidity : 65 ± 10 %
Input voltage : 220 V, 60 Hz
- (6) Adjustment equipments: Color Analyzer(CA-210 or CA-110), DDC Adjustment Jig, Service remote control.
- (7) Push the "IN STOP" key - For memory initialization.

Case1 : Software version up

1. After downloading S/W by USB , TV set will reboot automatically.
2. Push "In-stop" key.
3. Push "Power on" key.
4. Function inspection
5. After function inspection, Push "In-stop" key.

Case2 : Function check at the assembly line

1. When TV set is entering on the assembly line, Push "In-stop" key at first.
2. Push "Power on" key for turning it on.
→ If you push "Power on" key, TV set will recover channel information by itself.
3. After function inspection, Push "In-stop" key.

3. Main PCB check process

- APC - After Manual-Insert, executing APC

* Boot file Download

- (1) Execute ISP program "Mstar ISP Utility" and then click "Config" tab.
- (2) Set as below, and then click "Auto Detect" and check "OK" message.
If "Error" is displayed, check connection between computer, jig, and set.
- (3) Click "Read" tab, and then load download file(XXXX.bin) by clicking "Read".

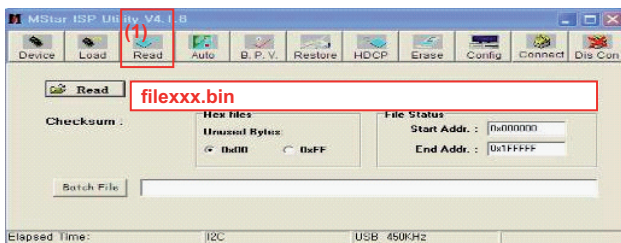

- (4) Click "Connect" tab. If "Can't" is displayed, check connection between computer, jig, and set.

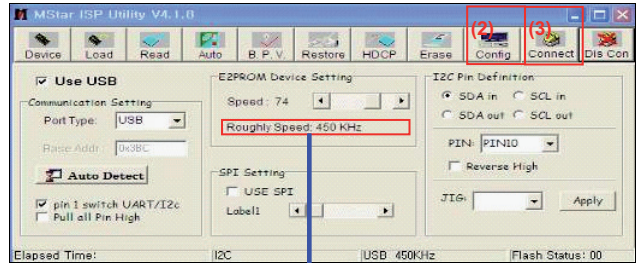

Please Check the Speed :
To use speed between
from 200KHz to 400KHz

- (5) Click "Auto" tab and set as below.
- (6) Click "Run".
- (7) After downloading, check "OK" message.

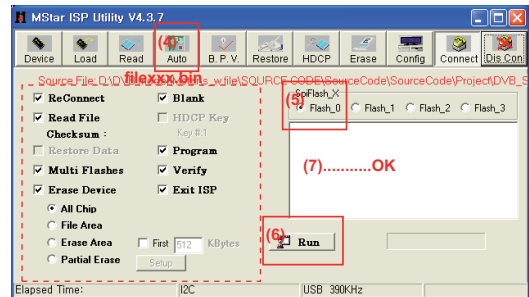

* USB DOWNLOAD

- (1) Put the USB Stick to the USB socket.
- (2) Automatically detecting update file in USB Stick.
- If your downloaded program version in USB Stick is Low, it didn't work. But your downloaded version is High, USB data is automatically detecting.
- (3) Show the message "Copying files from memory".
- (4) Updating is starting.

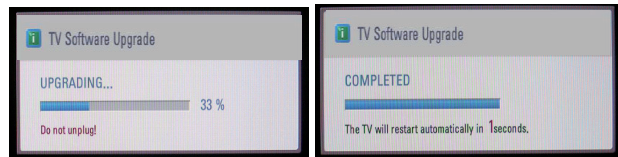

- (5) Updating Completed, The TV will restart automatically in 5 seconds.
 - (6) If your TV is turned on, check your updated version and Tool option. (explain the Tool option, next stage)
- * If downloading version is more new than your TV have, TV can lost all channel data. In this case, you have to channel recover. if all channel data is cleared, you didn't have a DTV/ATV test on production line.

* After downloading, have to adjust Tool Option again.

- (1) Push "IN-START" key in service remote control.
- (2) Select "Tool Option 1" and push "OK" key.
- (3) Punch in the number. (Each model has their number)
- (4) Completed selecting Tool option.

3.1. ADC Process(Optional)

* If ADC processes as OTP, There is no need to proceed internal ADC.

- Enter Service Mode by pushing "ADJ" key,
- Enter Internal ADC mode by pushing "▶" key at "8. ADC Calibration".

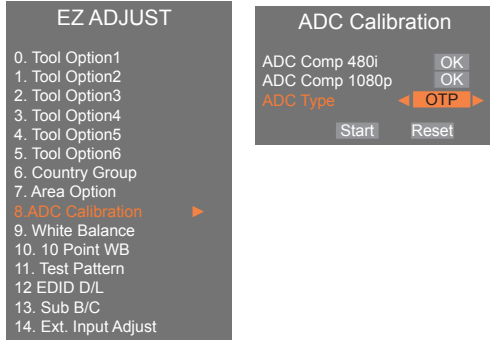

<Caution> Using "P-ONLY" key of the Adjustment remote control, power on TV.

* ADC Calibration Protocol (RS232)

No.	Item	CMD 1	CMD 2	Data 0	
Enter Adjust MODE	Adjust 'Mode In'	A	A	0	0
ADC adjust	ADC Adjust	A	D	1	0

When transfer the 'Mode In', Carry the command.
Automatically adjustment (The use of a internal pattern)

Adjust Sequence

- aa 00 00 [Enter Adjust Mode]
- xb 00 40 [Component Input]
- ad 00 10 [Adjust 480i & 1080p Comp]
- aa 00 90 End Adjust mode

* Required equipment : Adjustment remote control.

3.2. EDID Download

- After enter Service Mode by pushing "ADJ" key.
- Enter EDID D/L menu.
- Enter "START" by pushing "OK" key.

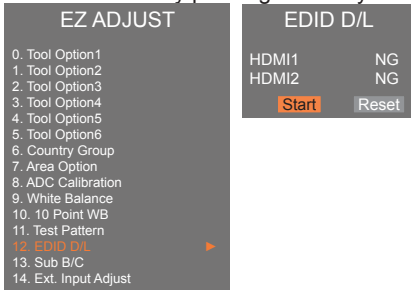

<Caution> Never connect HDMI cable when EDID downloaded.

3.3. EDID data

(1) 2D HD Model HDMI EDID data

	0	1	2	3	4	5	6	7	8	9	A	B	C	D	E	F
00	00	FF	FF	FF	FF	FF	FF	00	1E	6D	a		b			
10	c		01	03	80	A0	5A	78	0A	EE	91	A3	54	4C	99	26
20	0F	50	54	A1	08	00	31	40	45	40	61	40	71	40	01	01
30	01	01	01	01	01	01	66	21	50	B0	51	00	1B	30	40	70
40	36	00	40	84	63	00	00	1E	64	19	00	40	41	00	26	30
50	18	88	36	00	40	84	63	00	00	18	00	00	00	FD	00	3A
60	3E	1E	53	10	00	0A	20	20	20	20	20	20	d			
70	d														01	e
80	02	03	22	F1	4E	10	1F	04	93	05	14	03	02	12	20	21
90	22	15	01	26	15	07	50	09	57	07	f					
A0	f		01	1D	80	18	71	1C	16	20	58	2C	25	00	A0	5A
B0	00	00	00	9E	01	1D	00	72	51	D0	1E	20	6E	28	55	00
C0	20	C2	31	00	00	1E	8C	0A	D0	8A	20	E0	2D	10	10	3E
D0	96	00	A0	5A	00	00	00	18	02	3A	80	18	71	38	2D	40
E0	58	2C	45	00	A0	5A	00	00	00	1E	00	00	00	00	00	00
F0	00	00	00	00	00	00	00	00	00	00	00	00	00	00	00	e

(2) 2D FHD Model HDMI EDID data

	0	1	2	3	4	5	6	7	8	9	A	B	C	D	E	F
00	00	FF	FF	FF	FF	FF	FF	00	1E	6D	a		b			
10	c		01	03	80	A0	5A	78	0A	EE	91	A3	54	4C	99	26
20	0F	50	54	A1	08	00	31	40	45	40	61	40	71	40	81	80
30	01	01	01	01	01	01	02	3A	80	18	71	38	2D	40	58	2C
40	45	00	A0	5A	00	00	00	1E	66	21	50	B0	51	00	1B	30
50	40	70	36	00	A0	5A	00	00	00	1E	00	00	00	FD	00	3A
60	3E	1E	53	10	00	0A	20	20	20	20	20	20	d			
70	d														01	e
80	02	03	22	F1	4E	10	9F	04	13	05	14	03	02	12	20	21
90	22	15	01	26	15	07	50	09	57	07	f					
A0	f		01	1D	80	18	71	1C	16	20	58	2C	25	00	20	C2
B0	31	00	00	9E	01	1D	00	72	51	D0	1E	20	6E	28	55	00
C0	20	C2	31	00	00	1E	02	3A	80	18	71	38	2D	40	58	2C
D0	45	00	A0	5A	00	00	00	1E	01	1D	00	BC	52	D0	1E	20
E0	B8	28	55	40	C4	8E	21	00	00	1E	00	00	00	00	00	00
F0	00	00	00	00	00	00	00	00	00	00	00	00	00	00	00	e

(3) Detail EDID Options are below

a. Product ID

MODEL NAME	HEX	EDID Table	DDC Function
HD/FHD Model	0001	01 00	Analog/Digital

b. Serial No: Controlled on production line.

c. Month, Year:

ex) Week : '01' -> '01', Year : '2015' -> '19' fix

d. Model Name(Hex):

cf) TV set's model name in EDID data is below.

Model name	MODEL NAME(HEX)
LG TV	00 00 00 FC 00 4C 47 20 54 56 0A 20 20 20 20 20 20 (LG TV)

e. Checksum: Changeable by total EDID data.

EDID C/S data	HD	FHD
	HDMI	HDMI
Block 0	74	40
Check sum (Hex)	5B (HDMI1)	25 (HDMI1)
	4B (HDMI2)	15 (HDMI2)

f. Vendor Specific(HDMI)

INPUT	Model name(HEX)
HDMI1	67 03 0C 00 10 00 80 1E
HDMI2	67 03 0C 00 20 00 80 1E

3.4. Function Check

- Check display and sound
 - Check Input and Signal items.
 - 1) TV
 - 2) AV (SCART / CVBS)
 - 3) COMPONENT (480i)
 - 4) HDMI
- * Display and Sound check is executed by Remote control.

<Caution>

Not to push the INSTOP key after completion if the function inspection.

4. Total Assembly line process

4.1. White Balance adjustment

- W/B Equipment condition
CA210 : LED → CH14, Test signal: Inner pattern(80IRE)
- Above 5 minutes H/run in the inner pattern. ("power on" key of adjust remote control)
- If it is executed W/B adjustment in 2~3 minutes H/run, it is adjusted by Target data.

Mode	Temp	Coordinate spec	Target
Cool	13,000 K	X=0.271 (± 0.002) Y=0.270 (± 0.002)	X=0.278 Y=0.280
Medium	9,300 K	X=0.286 (± 0.002) Y=0.289 (± 0.002)	X=0.293 Y=0.299
Warm	6,500 K	X=0.313 (± 0.002) Y=0.329 (± 0.002)	X=0.320 Y=0.339

- Normal line(LGD/CMI, March ~ December for Gumi, Global)

NetCase5	Aging time (Min)	Cool		Medium		Warm	
		x	y	x	y	x	y
		271	270	286	289	313	329
1	0-2	282	289	297	308	324	348
2	3-5	281	287	296	306	323	346
3	6-9	279	284	294	303	321	343
4	10-19	277	280	292	299	319	339
5	20-35	275	277	290	296	317	336
6	36-49	274	274	289	293	316	333
7	50-79	273	272	288	291	315	331
8	80-119	272	271	287	290	314	330
9	Over 120	271	270	286	289	313	329

- Normal line(LGD/CMI, January ~ February for Gumi, Apply not Cinema Screen)

NetCase5	Aging time (Min)	Cool		Medium		Warm	
		x	y	x	y	x	y
		271	270	286	289	313	329
1	0-2	286	295	301	314	328	354
2	3-5	284	290	299	309	326	349
3	6-9	282	287	297	306	324	346
4	10-19	279	283	294	302	321	342
5	20-35	276	278	291	297	318	337
6	36-49	274	275	289	294	316	334
7	50-79	273	272	288	291	315	331
8	80-119	272	271	287	290	314	330
9	Over 120	271	270	286	289	313	329

- Aging chamber(LGD/CMI)

NetCase4	Aging time (Min)	Cool		Medium		Warm	
		x	y	x	y	x	y
		271	270	285	293	313	329
1	0-5	280	285	294	308	319	340
2	6-10	276	280	290	303	315	335
3	11-20	272	275	286	298	311	330
4	21-30	269	272	283	295	308	327
5	31-40	267	268	281	291	306	323
6	41-50	266	265	280	288	305	320
7	51-80	265	263	279	286	304	318
8	81-119	264	261	278	284	303	316
9	Over 120	264	260	278	283	303	315

- Use only AUO/Sharp/CSOT(Cool temp Spec is 13000 K)

	Cool		Medium		Warm	
	x	y	x	y	x	y
spec	271	270	286	289	313	329
target	278	280	293	299	320	339

- W/B information

Model information				W/B information
Model	Module	Panel	Backlight Type	Using W/B table
All	All	All	Direct LED	O

- * Connecting picture of the measuring instrument (On Automatic control)

Inside PATTERN is used when W/B is controlled. Connect to auto controller or push Adjustment R/C P-ONLY → Enter the mode of White-Balance, the pattern will come out.

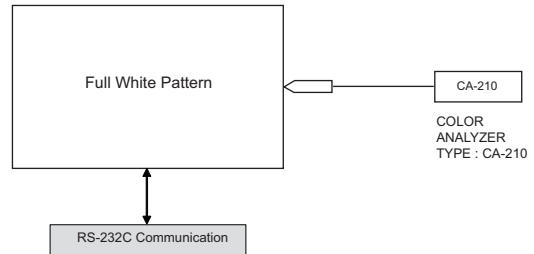

- * Auto-control interface and directions

- (1) Adjust in the place where the influx of light like floodlight around is blocked. (illumination is less than 10 lux).
- (2) Adhere closely the Color analyzer(CA210) to the module less than 10 cm distance, keep it with the surface of the Module and Color analyzer's prove vertically.(80° ~ 100°).
- (3) Aging time
 - After aging start, keep the power on (no suspension of power supply) and heat-run over 5 minutes.
 - Using 'no signal' or 'POWER ONLY' or the others, check the back light on.

- Auto adjustment Map(using RS-232C to USB cable)

RS-232C COMMAND

[CMD ID DATA]

Wb 00 00 White Balance Start
 Wb 00 ff White Balance End

	RS-232C COMMAND [CMD ID DATA]			MIN	CENTER (DEFAULT)			MAX
	Cool	Mid	Warm		Cool	Mid	Warm	
R Gain	jg	Ja	jd	00	172	192	192	254
G Gain	jh	Jb	je	00	172	192	192	192
B Gain	ji	Jc	jf	00	192	192	172	254
R Cut					64	64	64	128
G Cut					64	64	64	128
B Cut					64	64	64	128

<Caution>

Color Temperature : COOL, Medium, Warm.

One of R Gain/G Gain/ B Gain should be kept on 0xC0, and adjust other two lower than C0.(When R/G/B Gain are all C0, it is the FULL Dynamic Range of Module)

*** Manual W/B process using adjust Remote control.**

- After enter Service Mode by pushing "ADJ" key,
- Enter White Balance by pushing "▶" key at "9. White Balance".

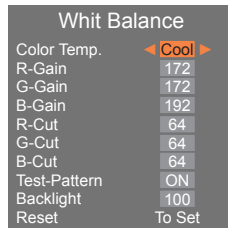

*** CASE Cool Mode**

First adjust the coordinate far away from the target value(x, y).B.

- x, y > target
- x, y < target
- x > target, y < target
- x < target, y > target
 - Every 4 case have to fit y value by adjusting B Gain and then fit x value by adjusting R-Gain.
 - In this case, increasing/decreasing of B Gain and R Gain can be adjusted.

How to adjust

- In case G gain more than 172
Adjust R Gain and B Gain less than 192
- If the G gain value be adjusted down to 172
One of the R/B Gain is 254
- If G Gain is 172 , More than one of R/B Gain is to be between 192~254

*** CASE Medium / Warm**

First adjust the coordinate far away from the target value(x, y).

- x, y > target
 - Decrease the R, G.
- x, y < target
 - First decrease the B gain,
 - Decrease the one of the others.
- x > target, y < target
 - First decrease B, so make y a little more than the target.
 - Adjust x value by decreasing the R
- x < target, y > target
 - First decrease B, so make x a little more than the target.
 - Adjust x value by decreasing the G

* After you finished all adjustments, Press "In-start" key and compare Tool option and Area option value with its BOM, if it is correctly same then unplug the AC cable. If it is not same, then correct it same with BOM and unplug AC cable. For correct it to the model's module from factory Jig model.

* Push the "IN STOP" key after completing the function inspection. And Mechanical Power Switch must be set "ON".

4.2. 3D function test

(Pattern Generator MSHG-600, MSPG-6100[Support HDMI1.4])

* HDMI mode NO. 872 , pattern No.83

(1) Please input 3D test pattern like below.



(2) When 3D OSD appear automatically , then select OK key.



(3) Don't wear a 3D Glasses, Check the picture like below.



4.3. IR emitter inspection

- (1) Start 3D pattern inspection.
- (2) If IR emitter signal is correctly received to IR receiver, the lamp of IR tester turns on.

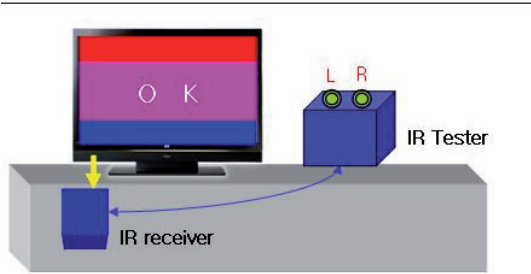

Fig.1
<IR Emitter inspection>



Fig.2
<IR Tester Lamp turned off(OFF)>



Fig.3
<IR Tester Lamp turned on(ON)>

4.4. Outgoing condition Configuration

- When pressing IN-STOP key by SVC remocon, Red LED are blinked alternatively. And then automatically turn off. (Must not AC power OFF during blinking)

5. HI-POT Test

5.1. HI-POT auto-check preparation

- Check the POWER cable and SIGNAL cable insertion condition

5.2. HI-POT auto-check

- (1) Pallet moves in the station. (POWER CORD / AV CORD is tightly inserted)
- (2) Connect the AV JACK Tester.
- (3) Controller (GWS103-4) on.
- (4) HI-POT test (Auto)
 - If Test is failed, Buzzer operates.
 - If Test is passed, GOOD Lamp on and move to next process automatically.

5.3. Checkpoint

- (1) Test voltage
 - Touchable Metal : 3 KV / min at 100 mA
 - SIGNAL : 3KV / min at 100 mA
- (2) TEST time: 1 second. (case : mass production)
- (3) TEST POINT
 - Touchable Metal => LIVE & NEUTRAL : Touchable Metal.
 - SIGNAL => LIVE & NEUTRAL : SIGNAL.

6. Model name & Serial number D/L

- Press "Power on" key of service remote control. (Baud rate : 115200 bps)
- Connect RS232 Signal Cable to USB Jack.
- Write Serial number
- Must check the serial number at the Diagnostics of SET UP menu. (Refer to below).

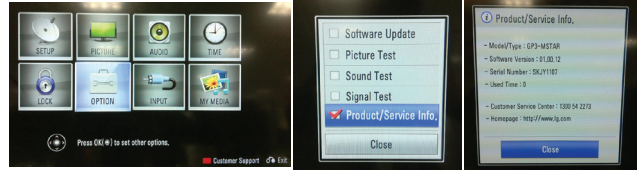

6.1. Signal Table

CMD	LENGTH	ADH	ADL	DATA_1	...	Data_n	CS	DELAY
-----	--------	-----	-----	--------	-----	--------	----	-------

CMD : A0h
 LENGTH : 85~94h (1~16 bytes)
 ADH : EEPROM Sub Address high (00~1F)
 ADL : EEPROM Sub Address low (00~FF)
 Data : Write data
 CS : CMD + LENGTH + ADH + ADL + Data_1 + ... + Data_n
 Delay : 20ms

6.2. Command Set

Adjust mode	CMD(hex)	LENGTH(hex)	Description
EEPROM WRITE	A0h	84h+n	n-bytes Write (n = 1~16)

- * Description
- FOS Default write : <7mode data> write
- Vtotal, V_Frequency, Sync_Polarity, Htotal, Hstart, Vstart, 0, Phase
- Data write : Model Name and Serial Number write in EEPROM.

6.3. Method & notice

- (1) Serial number D/L is using of scan equipment.
- (2) Setting of scan equipment operated by Manufacturing Technology Group.
- (3) Serial number D/L must be conformed when it is produced in production line, because serial number D/L is mandatory by D-book 4.0.

- * Manual Download(Model Name and Serial Number)
- If the TV set is downloaded by OTA or Service man, sometimes model name or serial number is initialized.(Not always)
- There is impossible to download by bar code scan, so It need Manual download.

- 1) Press the "Instart" key of Adjustment remote control.
- 2) Go to the menu "6.Model Number D/L" like below photo.
- 3) Input the Factory model name or Serial number like photo.

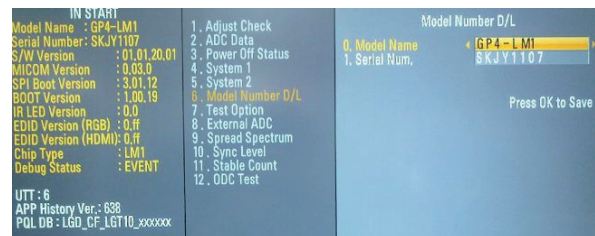

- 4) Check the model name Instart menu. → Factory name displayed. ex 47LF560V-ZA)
- 5) Check the Diagnostics.(DTV country only) → Buyer model displayed.(ex 47LF560V-ZA)

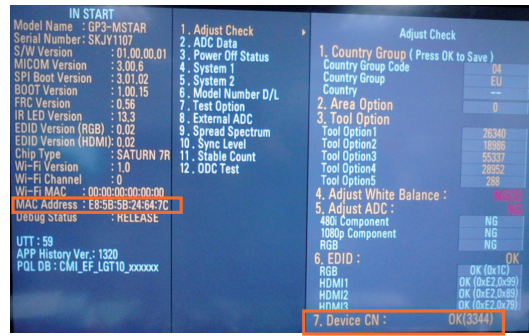
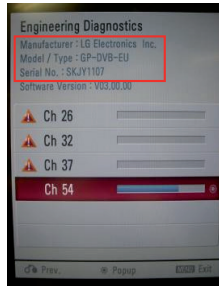

7. MAC Address & CI+ key download

7.1. MAC Address

7.1.1. Equipment & Condition

- Play file : Serial.exe
- MAC Address edit
- Input Start / End MAC address

7.1.2. Download method

(1) Communication Prot connection



Connection: PCBA(USB Port) → USB to Serial Adapter(UC-232A) → RS-232C cable → PC(RS-232C port)

* Caution: LJ21* chassis support only UC-232A driver. (only use this one.)

(2) MAC Address & CI+ Key Download

- Set CI+ Key path Directory at Start Mac & CI+ Download Programme
- Com 1,2,3,4 and 115200(Baudrate)

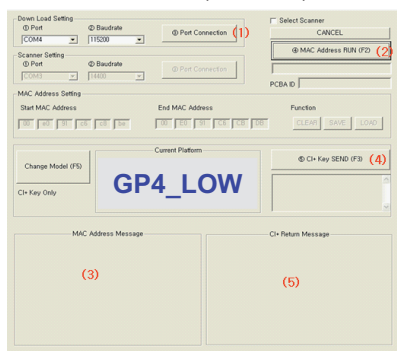

- Port connection button click(1)
- Push the (2) MAC Address write.
- At success Download, check the OK (3)
- Start CI+ Key Download, Push the (4)
- Check the OK or NG

7.2. LAN Inspection

7.2.1. Equipment & Condition

- Each other connection to LAN Port of IP Hub and Jig

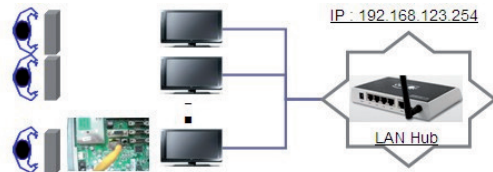

7.2.2. LAN inspection solution

- LAN Port connection with PCB
 - Network setting at MENU Mode of TV
 - Setting automatic IP
 - Setting state confirmation
- > If automatic setting is finished, you confirm IP and MAC Address.

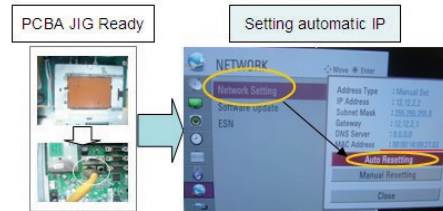

7.3. LAN PORT INSPECTION(PING TEST)

Connect SET -> LAN port == PC -> LAN Port



7.3.1. Equipment setting

- (1) Play the LAN Port Test PROGRAM.
- (2) Input IP set up for an inspection to Test Program.
*IP Number : 12.12.2.2

7.3.2. LAN PORT inspection (PING TEST)

- (1) Play the LAN Port Test Program.
- (2) Connect each other LAN Port Jack.
- (3) Play Test (F9) button and confirm OK Message.
- (4) Remove LAN cable.

BLOCK DIAGRAM

1. CIS T2/C/S2 3D Model

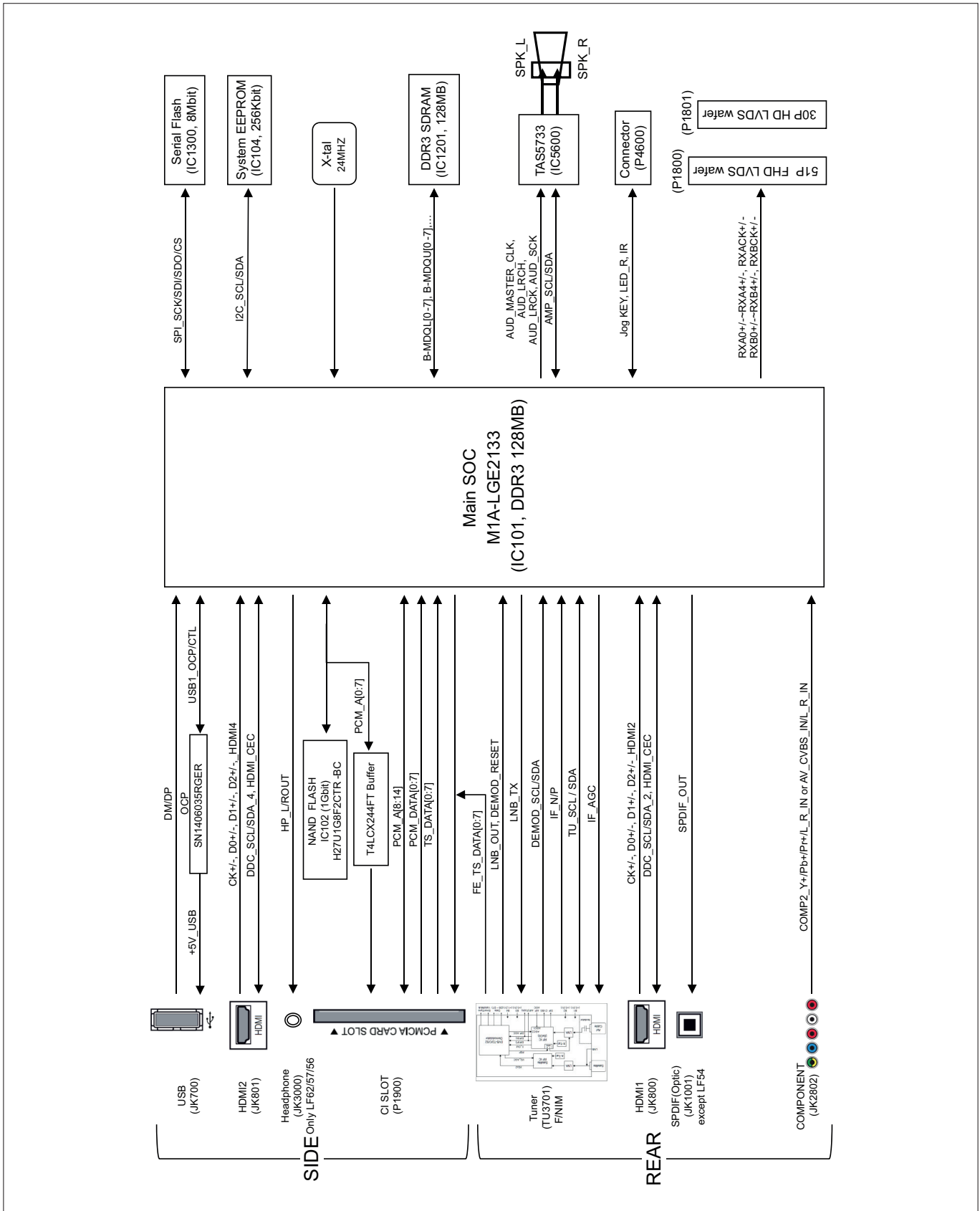

2. CIS T2/C/S2 2D Model

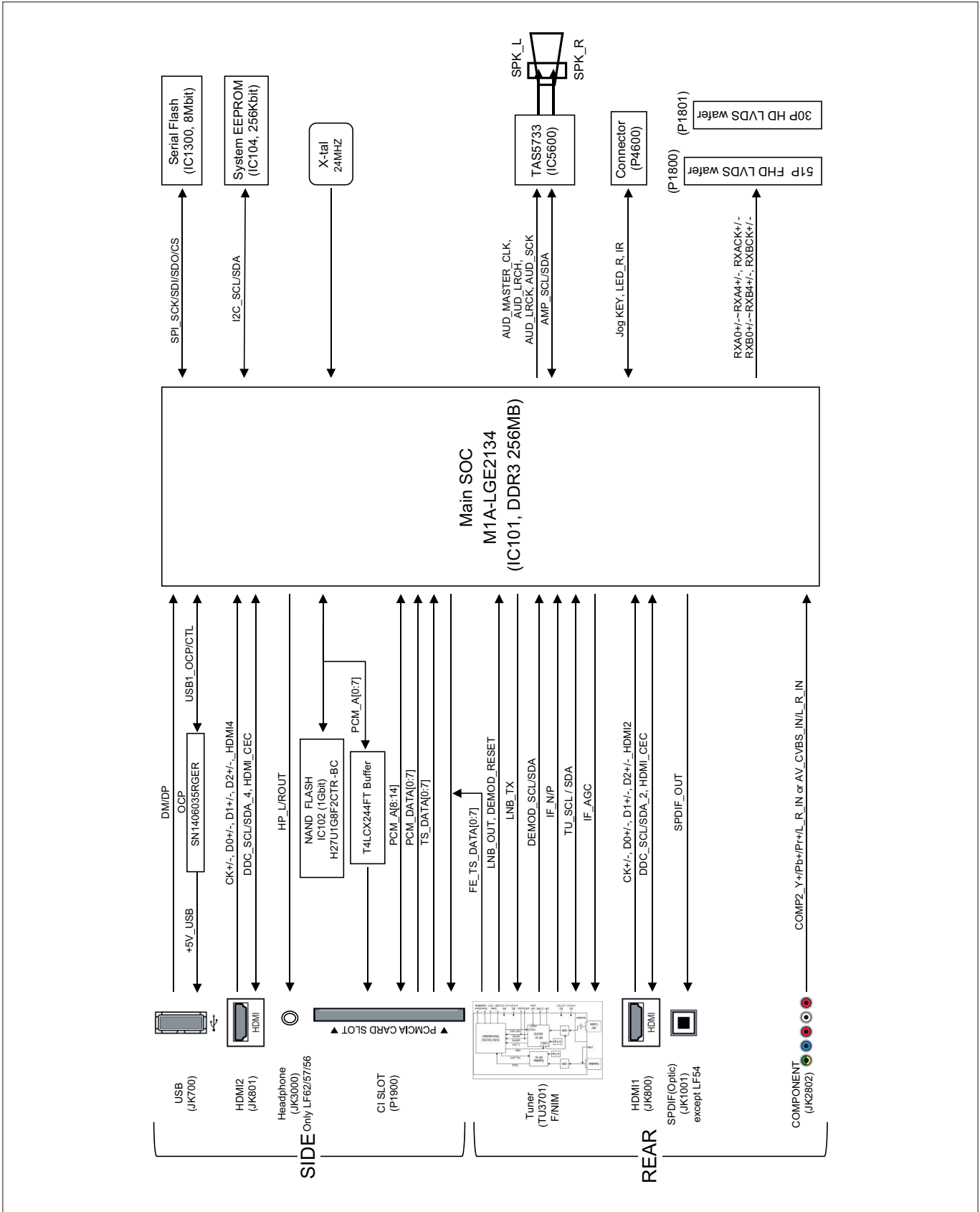

3. EU T2/C/S2 2D Model

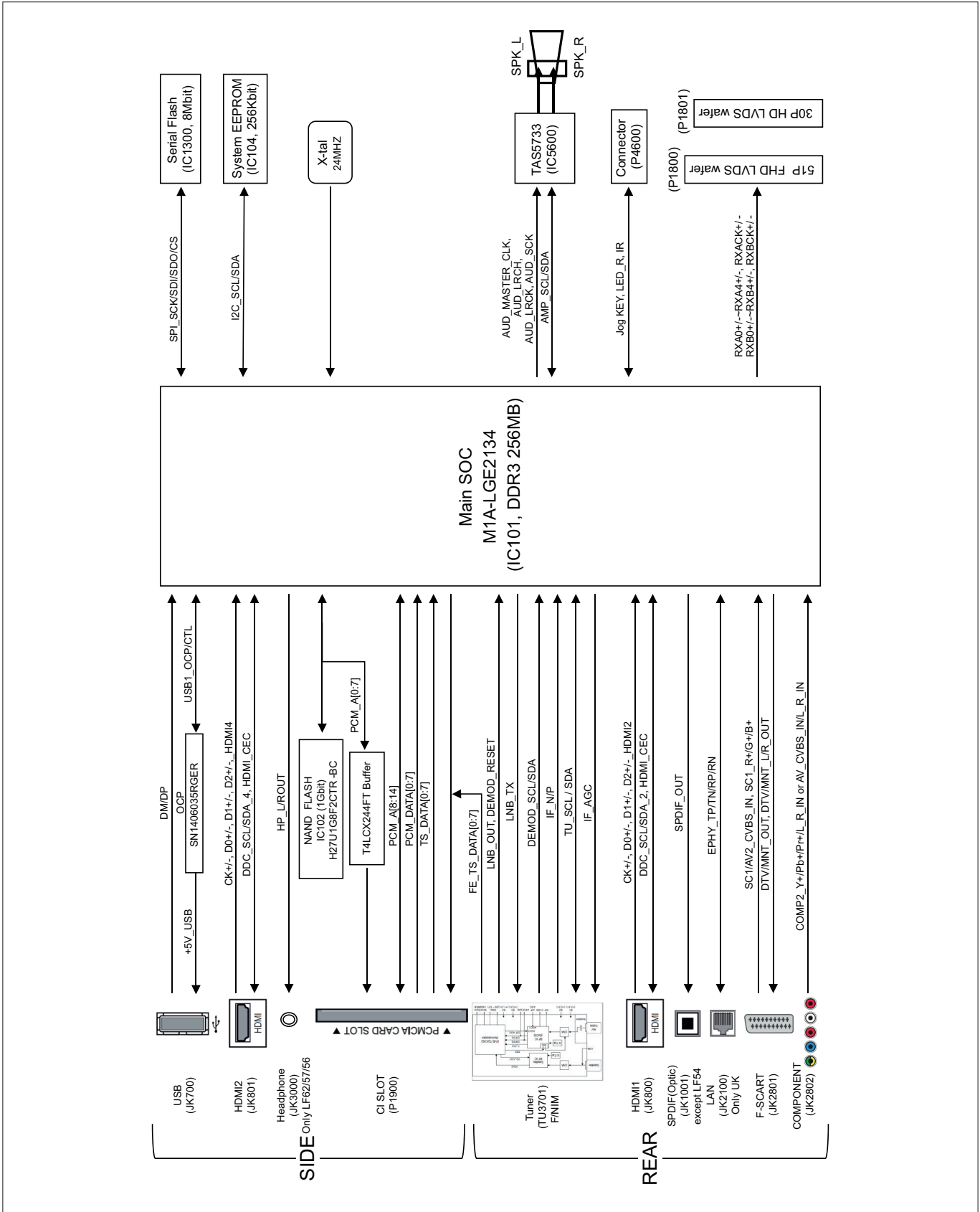

4. EU T/C 2D Model

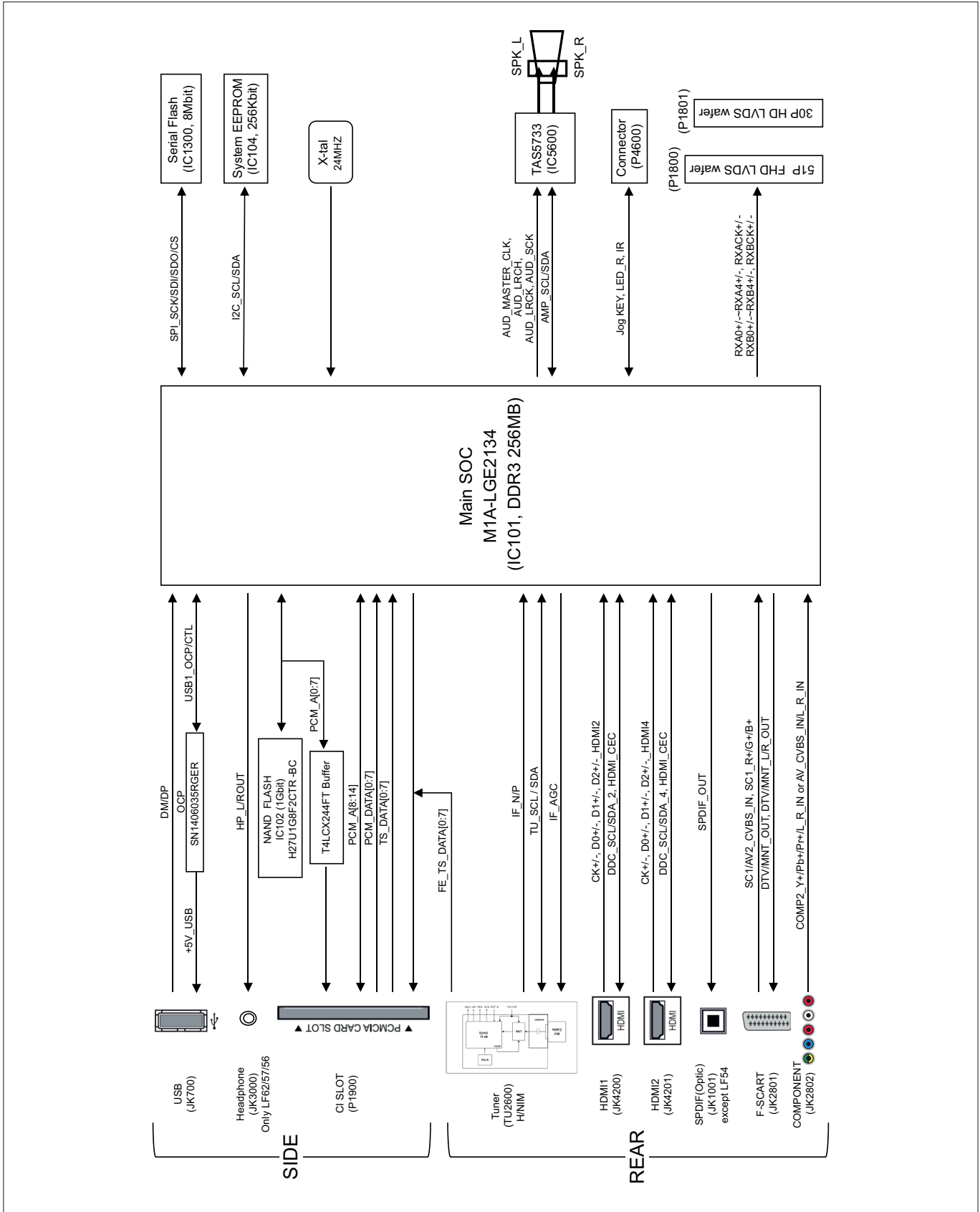

EXPLODED VIEW

IMPORTANT SAFETY NOTICE

Many electrical and mechanical parts in this chassis have special safety-related characteristics. These parts are identified by Δ in the Schematic Diagram and EXPLODED VIEW. It is essential that these special safety parts should be replaced with the same components as recommended in this manual to prevent Shock, Fire, or other Hazards. Do not modify the original design without permission of manufacturer.

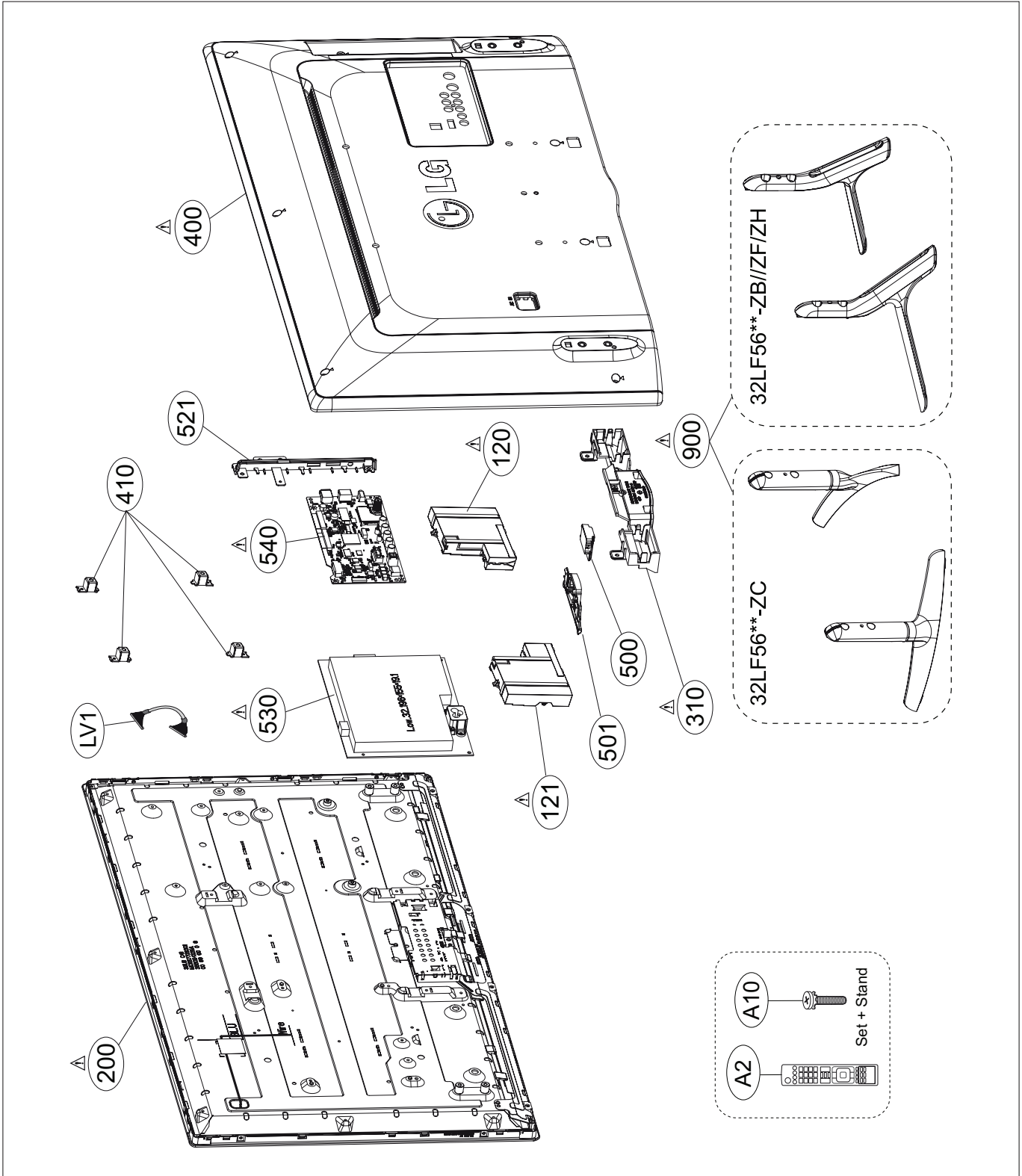

POWER

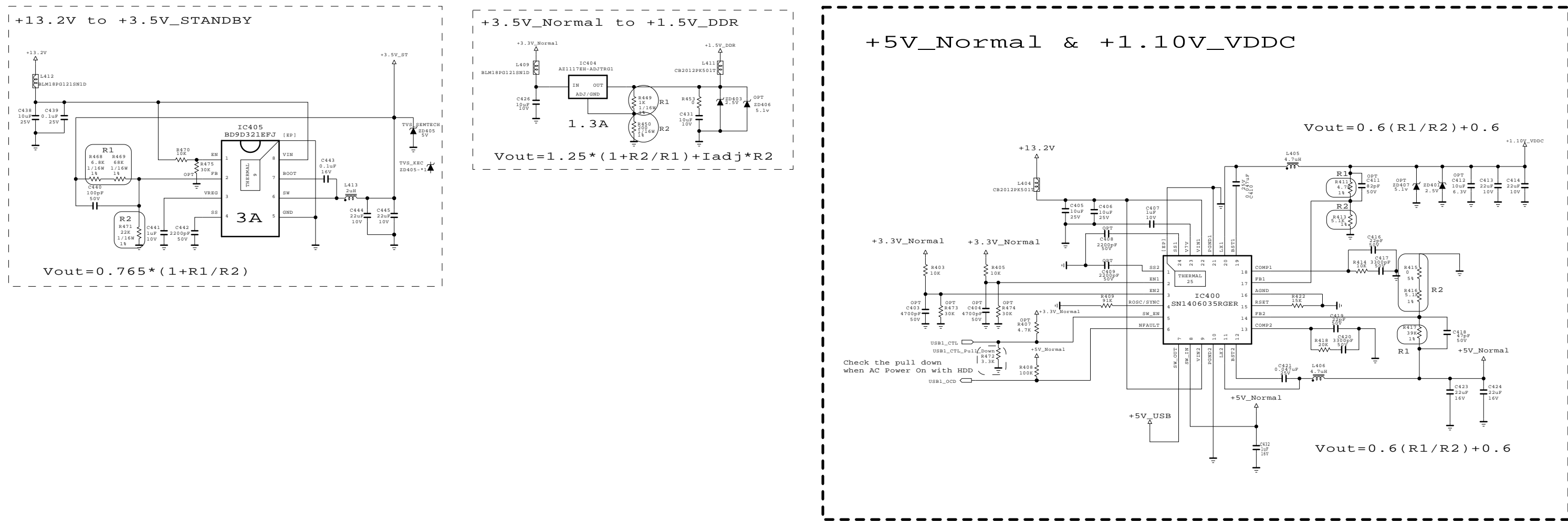
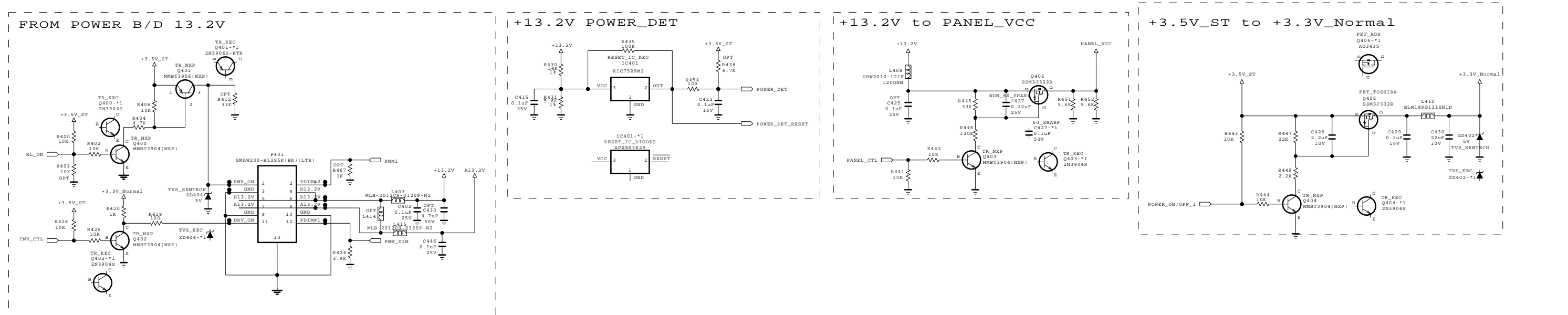

THE Δ SYMBOL MARK OF THIS SCHEMATIC DIAGRAM INCORPORATES SPECIAL FEATURES IMPORTANT FOR PROTECTION FROM X-RADIATION, FIRE AND ELECTRICAL SHOCK HAZARDS, WHEN SERVICING IT IS ESSENTIAL THAT ONLY MANUFACTURERS SPECIFIED PARTS BE USED FOR THE CRITICAL COMPONENTS IN THE Δ SYMBOL MARK OF THE SCHEMATIC.

SECRET
LGElectronics



MODEL	L14_CA	DATE	140826
BLOCK	POWER	SHEET	4

USB (SIDE)

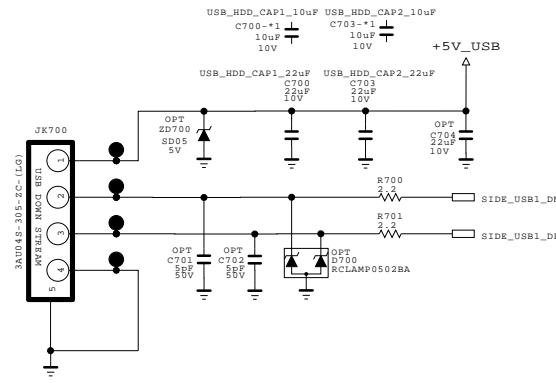

THE SYMBOL MARK OF THIS SCHEMATIC DIAGRAM INCORPORATES SPECIAL FEATURES IMPORTANT FOR PROTECTION FROM X-RADIATION, FIRE AND ELECTRICAL SHOCK HAZARDS, WHEN SERVICING IF IS ESSENTIAL THAT ONLY MANUFACTURERS SPECIFIED PARTS BE USED FOR THE CRITICAL COMPONENTS IN THE SYMBOL MARK OF THE SCHEMATIC.

SECRET
LGElectronics



MODEL	L14_CA_M1A	DATE	2014/05/20
BLOCK	USB_S1	SHEET	7 /

HDMI (REAR 1 / SIDE 1 MHL)

HDMI_1

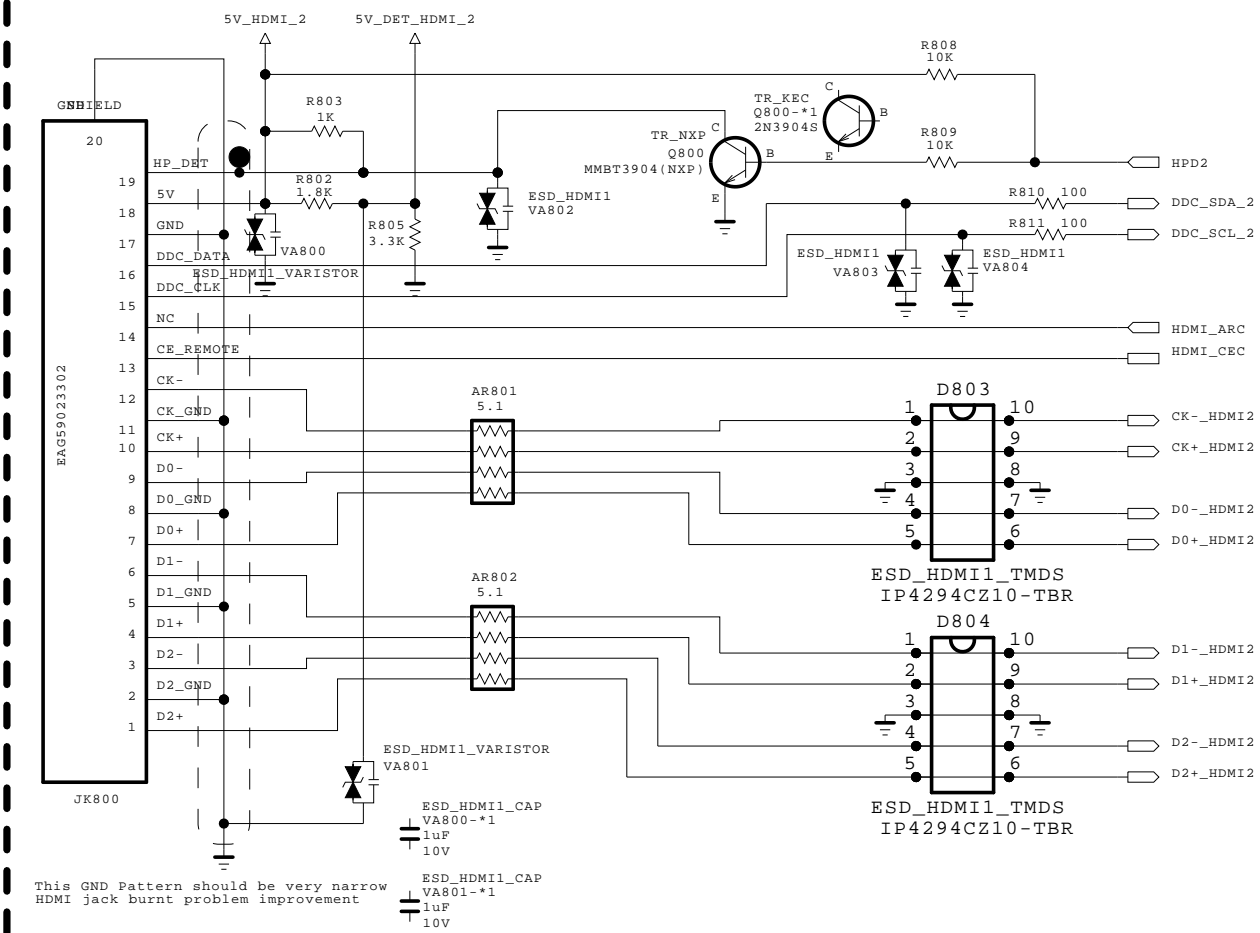

HDMI_2 MHL

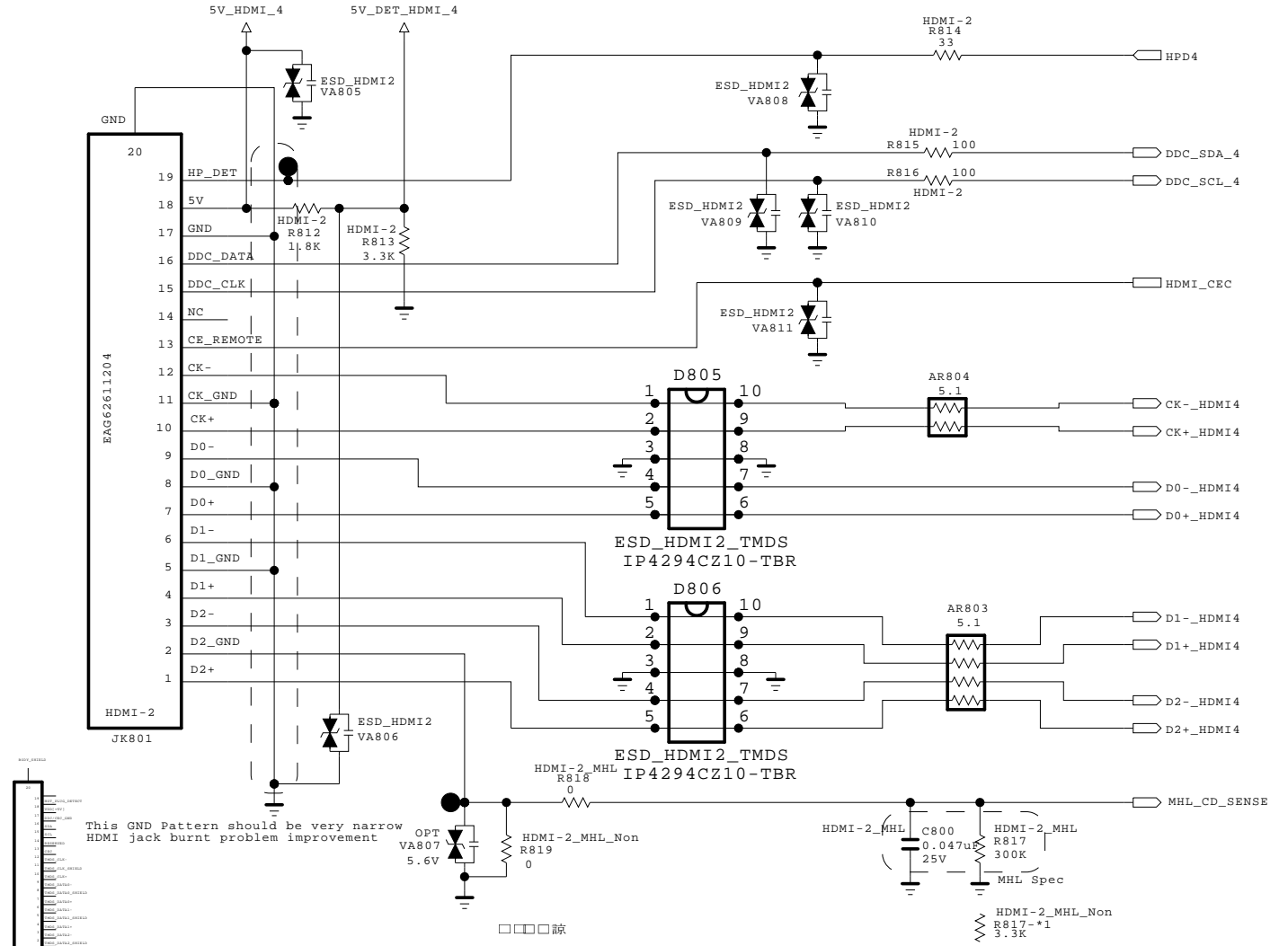

CEC

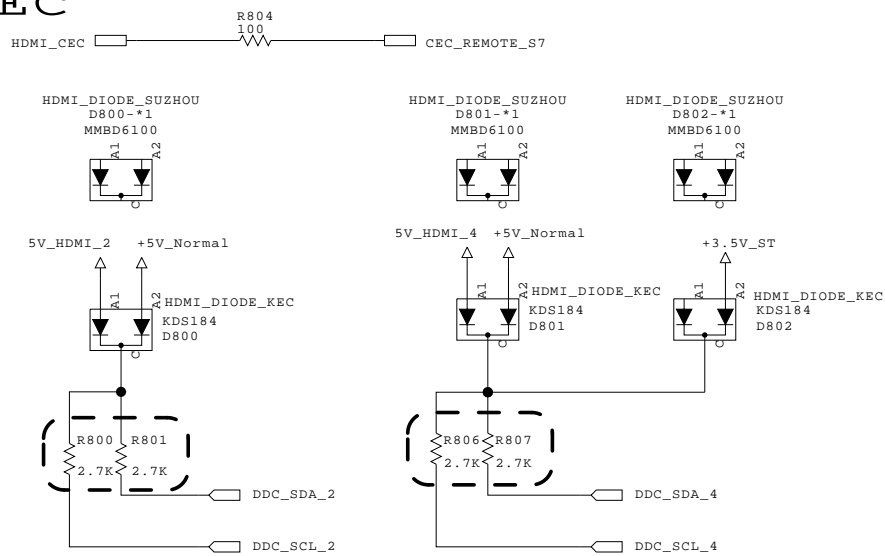

THE ⚠ SYMBOL MARK OF THIS SCHEMATIC DIAGRAM INCORPORATES SPECIAL FEATURES IMPORTANT FOR PROTECTION FROM X-RADIATION. FIRE AND ELECTRICAL SHOCK HAZARDS, WHEN SERVICING IF IS ESSENTIAL THAT ONLY MANUFACTURES SPECIFIED PARTS BE USED FOR THE CRITICAL COMPONENTS IN THE ⚠ SYMBOL MARK OF THE SCHEMATIC.

SECRET
LGElectronics



MODEL	L15_M1A	DATE	140813
BLOCK	HDMI_R1S1	SHEET	8 /

SPDIF

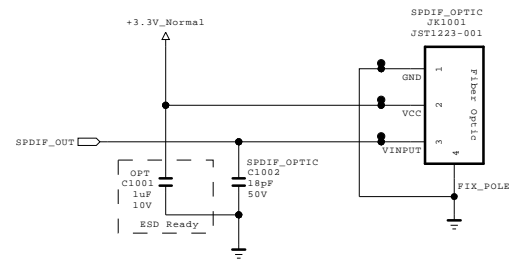

THE SYMBOL MARK OF THIS SCHEMATIC DIAGRAM INCORPORATES SPECIAL FEATURES IMPORTANT FOR PROTECTION FROM X-RADIATION, FIRE AND ELECTRICAL SHOCK HAZARDS, WHEN SERVICING IF IS ESSENTIAL THAT ONLY MANUFACTURES SPECIFIED PARTS BE USED FOR THE CRITICAL COMPONENTS IN THE SYMBOL MARK OF THE SCHEMATIC.



SECRET
LGElectronics

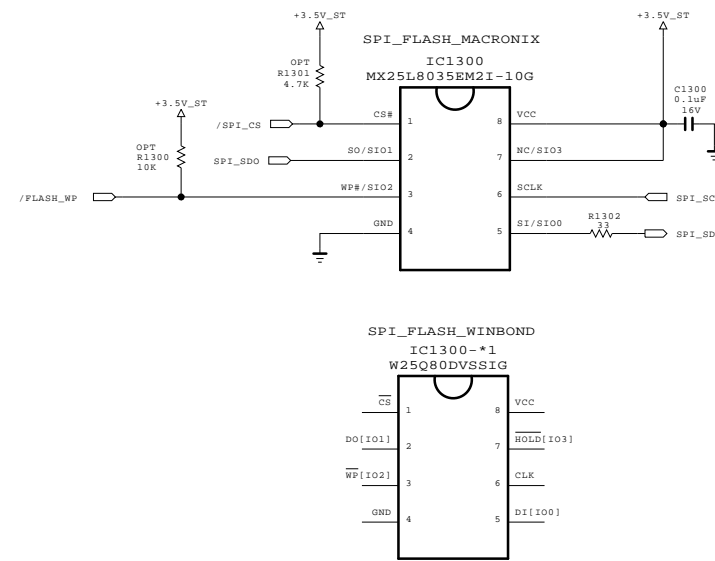

MODEL	L14_CA_M1A	DATE	2014/06/02
BLOCK	SPDIF	SHEET	10 /

Serial Flash for SPI boot



THE  SYMBOL MARK OF THIS SCHEMATIC DIAGRAM INCORPORATES SPECIAL FEATURES IMPORTANT FOR PROTECTION FROM X-RADIATION. FIRE AND ELECTRICAL SHOCK HAZARDS, WHEN SERVICING IF IS ESSENTIAL THAT ONLY MANUFACTURERS SPECIFIED PARTS BE USED FOR THE CRITICAL COMPONENTS IN THE  SYMBOL MARK OF THE SCHEMATIC.

SECRET
LGElectronics



MODEL	L14_CA_M1A	DATE	140721
BLOCK	S_FLASH	SHEET	13 /

LVDS

[51Pin LVDS Connector]
(For FHD 60Hz)

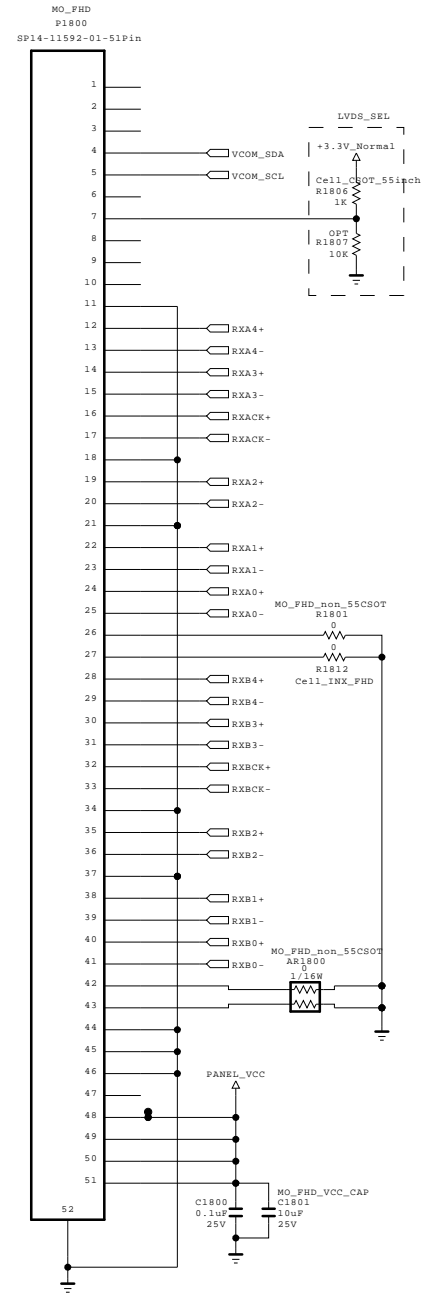

FOR FHD REVERSE(10bit)
Change in S7LR

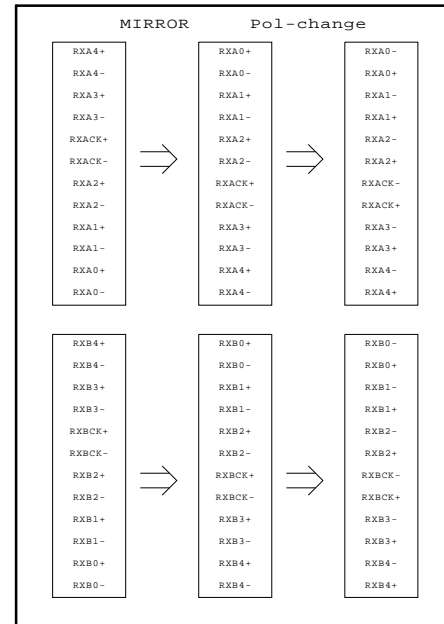

FOR FHD REVERSE(8bit)
Change in S7LR

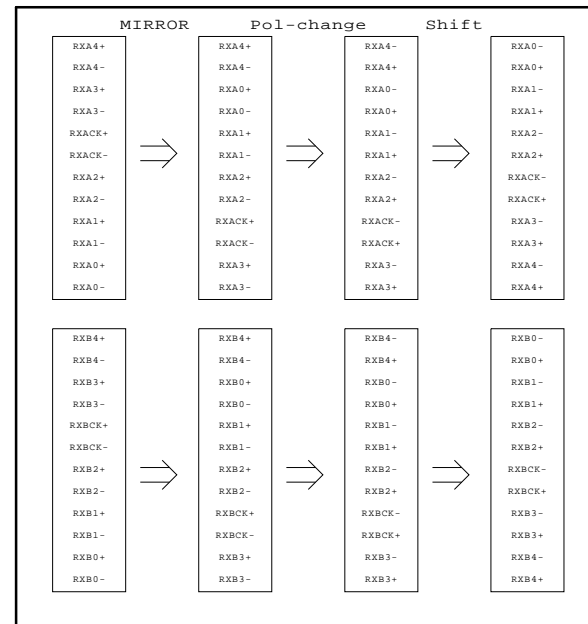

[30Pin LVDS Connector]
(For HD 60Hz_Normal)

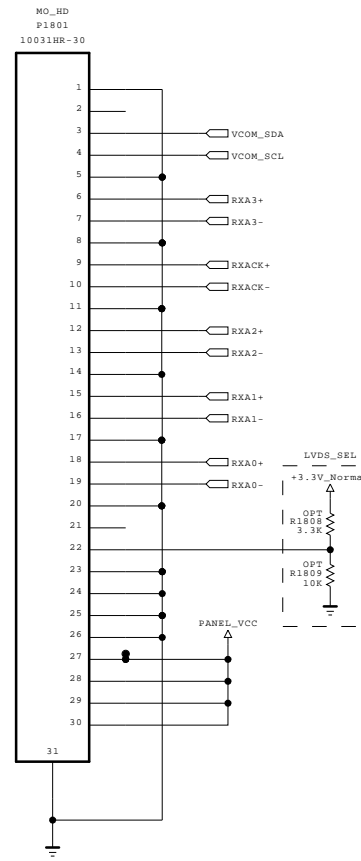

EU pin assign is different from NON EU.
Because of position of HD wafer.

V-COM I2C

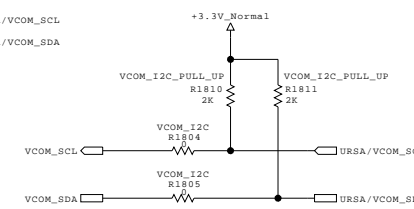

THE Δ SYMBOL MARK OF THIS SCHEMATIC DIAGRAM INCORPORATES SPECIAL FEATURES IMPORTANT FOR PROTECTION FROM X-RADIATION, FIRE AND ELECTRICAL SHOCK HAZARDS, WHEN SERVICING IF IS ESSENTIAL THAT ONLY MANUFACTURERS SPECIFIED PARTS BE USED FOR THE CRITICAL COMPONENTS IN THE Δ SYMBOL MARK OF THE SCHEMATIC.

SECRET
LGElectronics



MODEL	L14_CA_M1A	DATE	140613
BLOCK	LVDS	SHEET	18

CI Region

* Option name of this page : CI_SLOT
(because of Hong Kong)

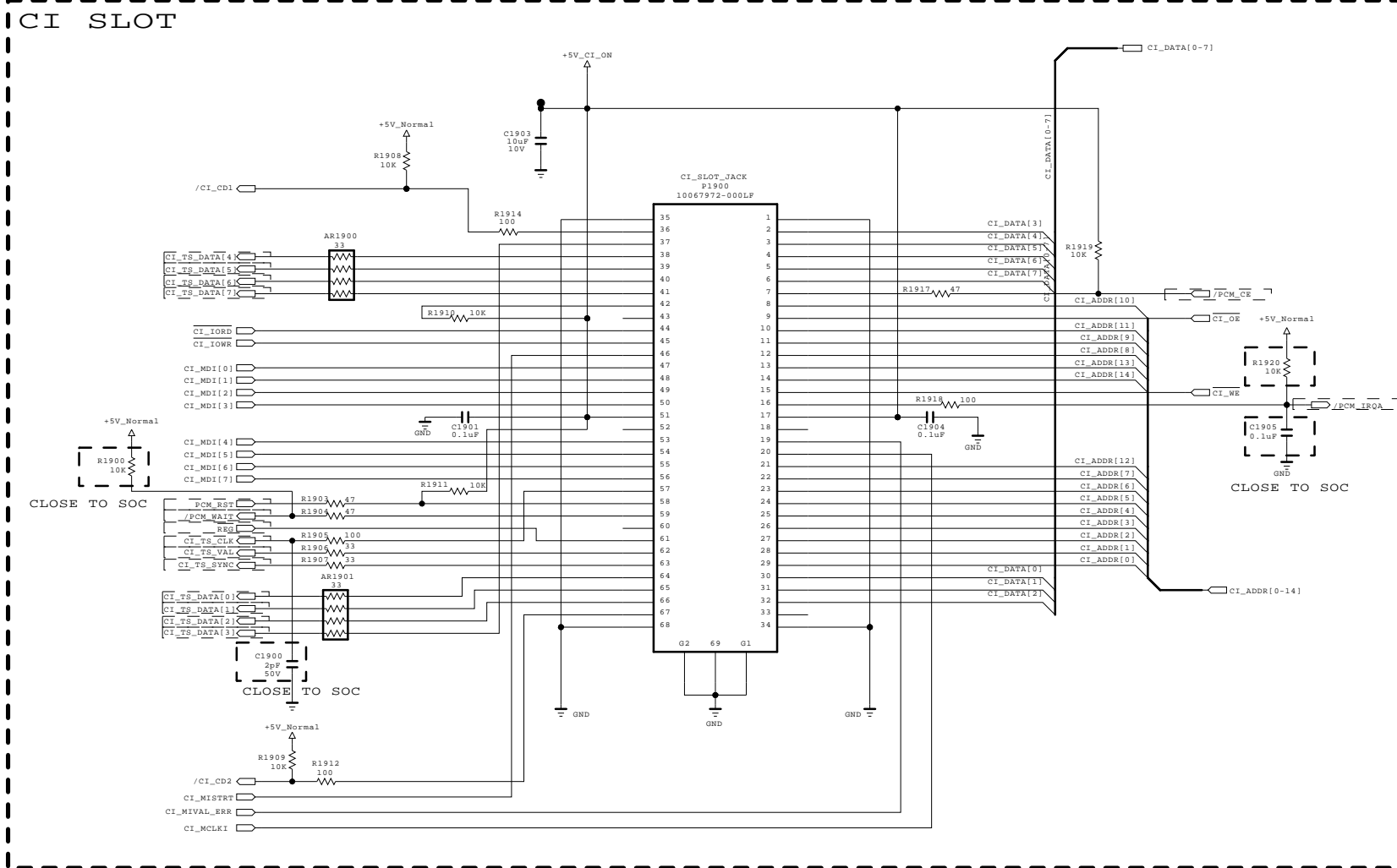

CI TS INPUT

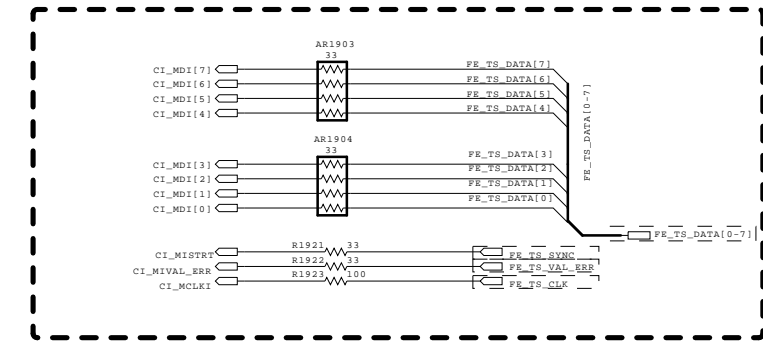

CI HOST I/F

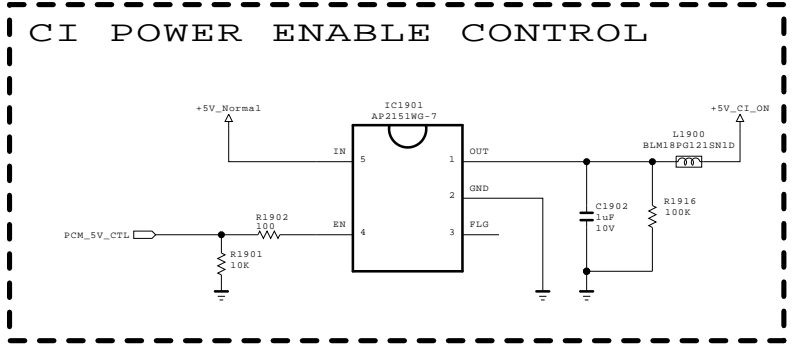
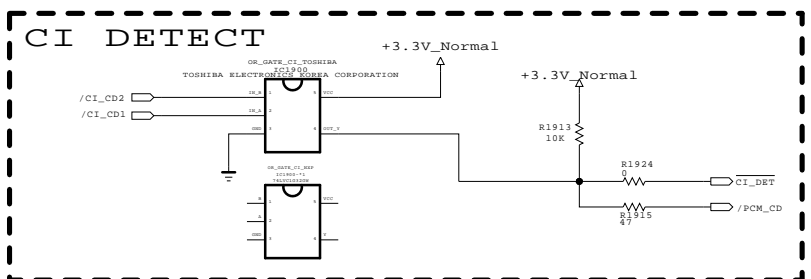
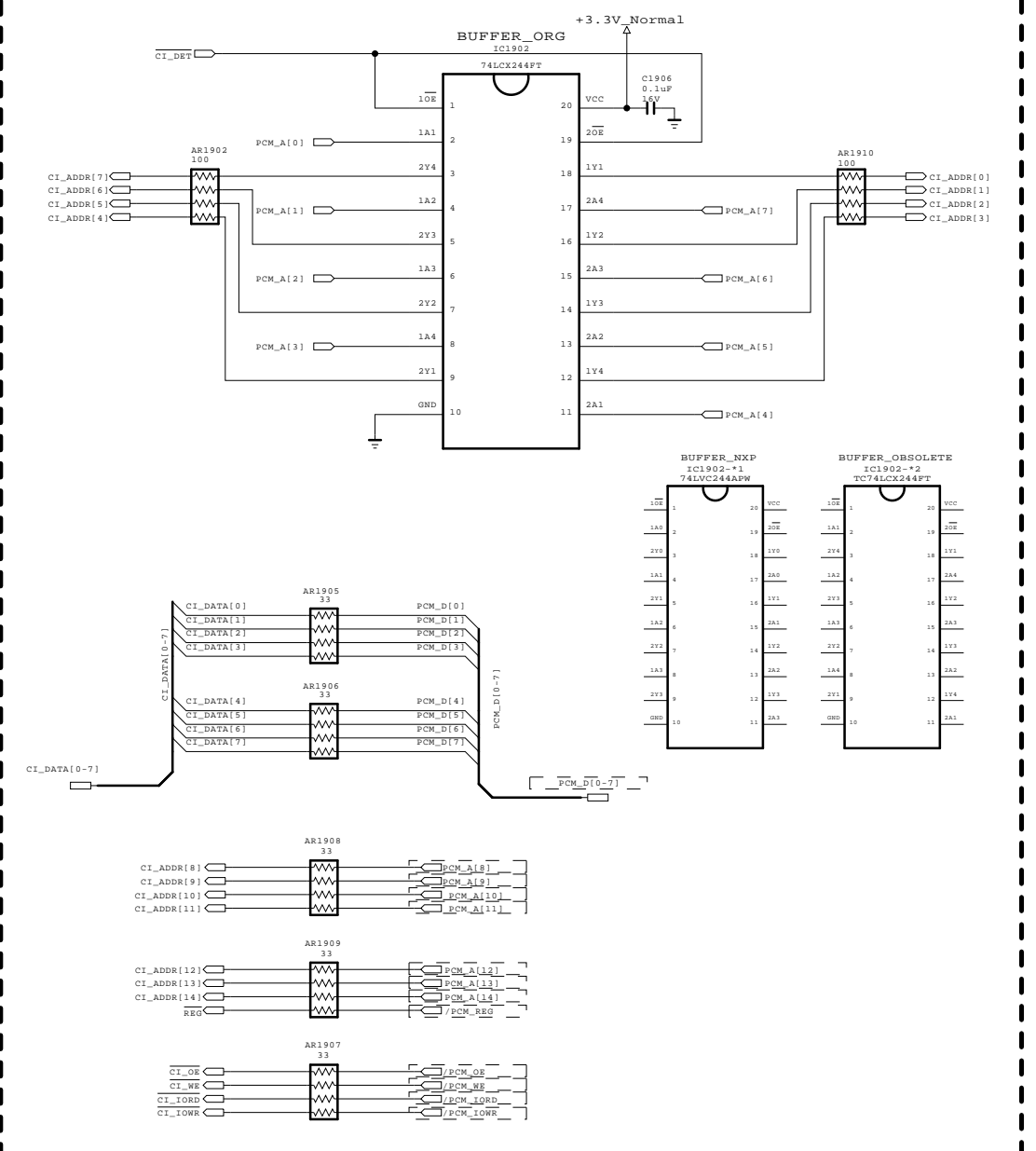

THE Δ SYMBOL MARK OF THIS SCHEMATIC DIAGRAM INCORPORATES SPECIAL FEATURES IMPORTANT FOR PROTECTION FROM X-RADIATION, FIRE AND ELECTRICAL SHOCK HAZARDS, WHEN SERVICING IF IS ESSENTIAL THAT ONLY MANUFACTURERS SPECIFIED PARTS BE USED FOR THE CRITICAL COMPONENTS IN THE Δ SYMBOL MARK OF THE SCHEMATIC.

SECRET
LGElectronics



MODEL	L14_CA_M1A	DATE	2014/06/25
BLOCK	PCMCIEU	SHEET	19

ETHERNET

* H/W option : ETHERNET

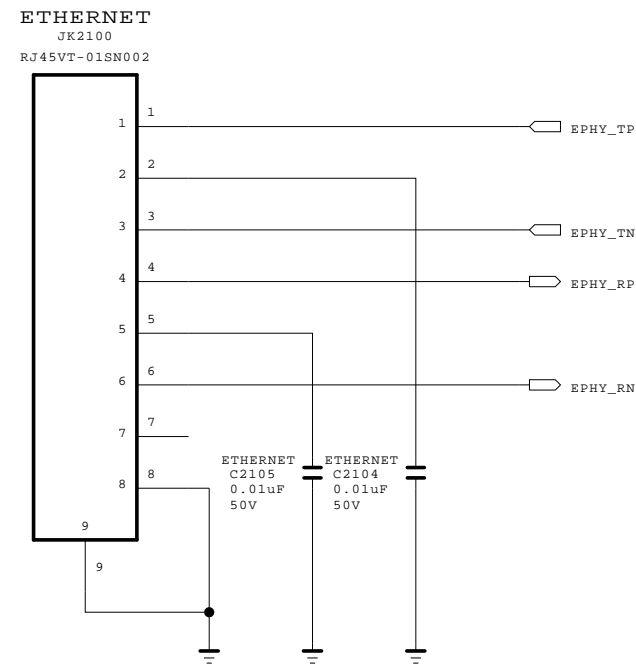

THE ⚠ SYMBOL MARK OF THIS SCHEMATIC DIAGRAM INCORPORATES SPECIAL FEATURES IMPORTANT FOR PROTECTION FROM X-RADIATION. FIRE AND ELECTRICAL SHOCK HAZARDS, WHEN SERVICING IF IS ESSENTIAL THAT ONLY MANUFACTURERS SPECIFIED PARTS BE USED FOR THE CRITICAL COMPONENTS IN THE ⚠ SYMBOL MARK OF THE SCHEMATIC.

SECRET	 LG ELECTRONICS
LGElectronics	

MODEL	L14_CA_M1A	DATE	2014/05/21
BLOCK	LAN	SHEET	21 /

DVB-S2 LNB Part Allegro

(Option:LNB)

Input trace widths should be sized to conduct at least 3A
 Output trace widths should be sized to conduct at least 2A

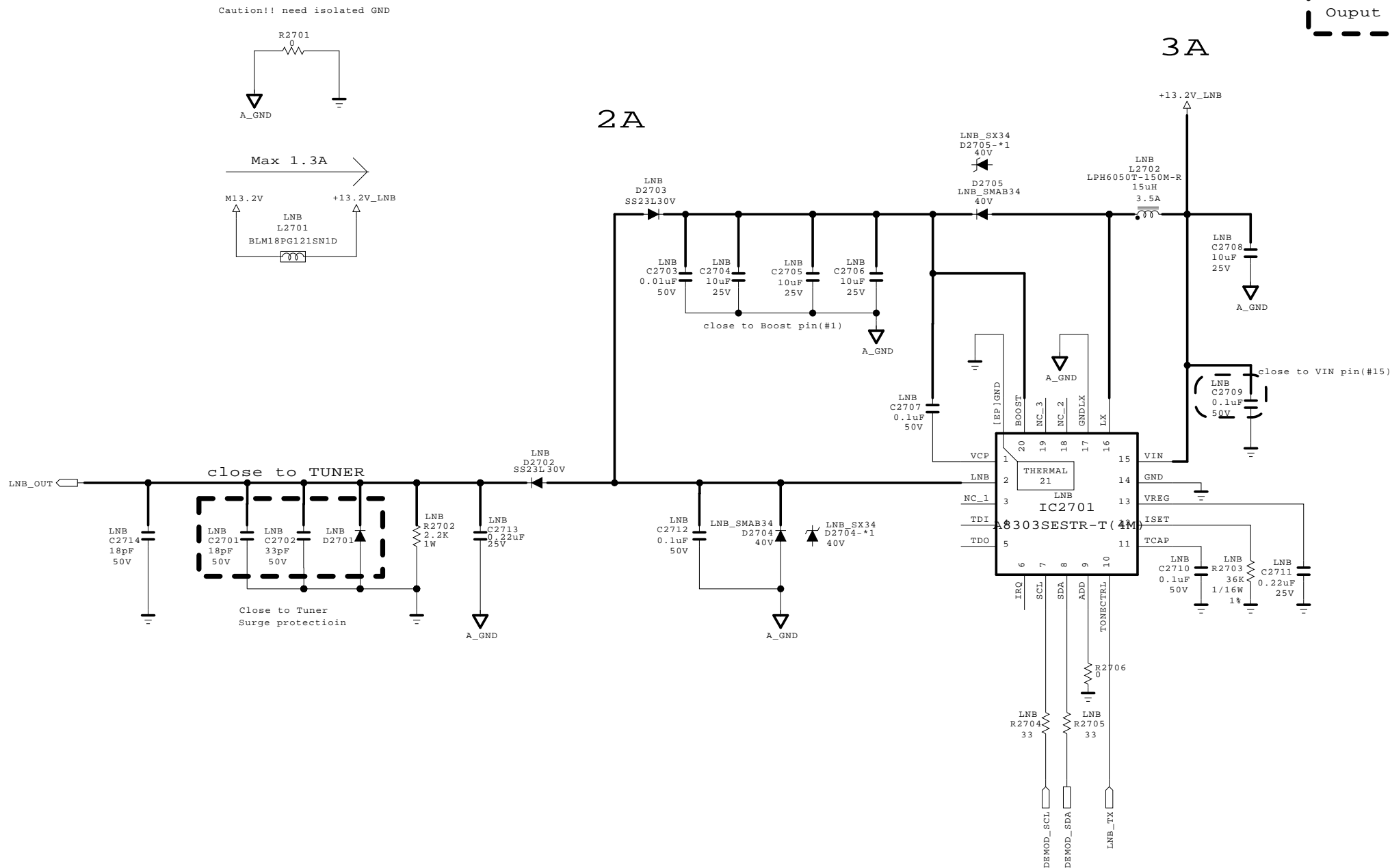

THE ⚠ SYMBOL MARK OF THIS SCHEMATIC DIAGRAM INCORPORATES SPECIAL FEATURES IMPORTANT FOR PROTECTION FROM X-RADIATION. FIRE AND ELECTRICAL SHOCK HAZARDS, WHEN SERVICING IF IS ESSENTIAL THAT ONLY MANUFACTURES SPECIFIED PARTS BE USED FOR THE CRITICAL COMPONENTS IN THE ⚠ SYMBOL MARK OF THE SCHEMATIC.

SECRET	LG ELECTRONICS
LGElectronics	

MODEL	L14_CA_M1A	DATE	2014/05/22
BLOCK	LNB	SHEET	27 /

SCART_COMPONENT

COMPONENT

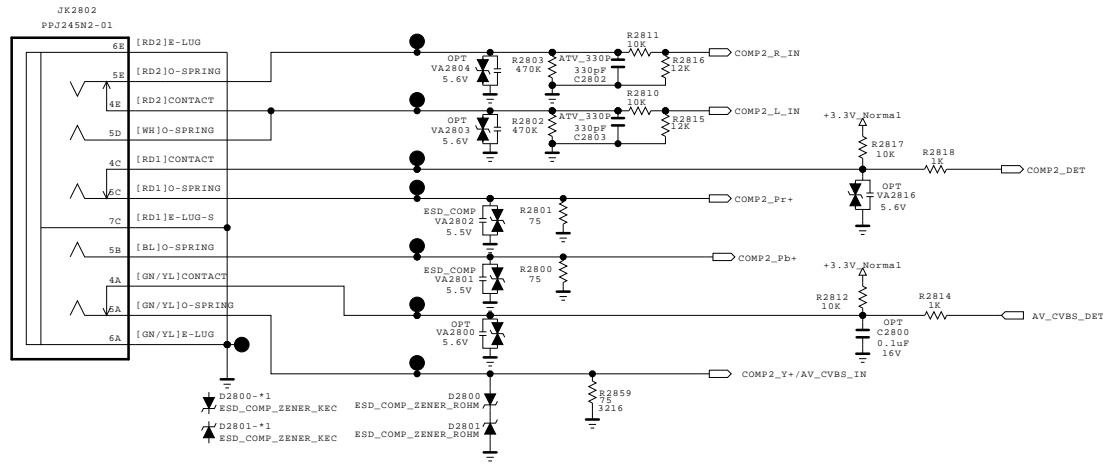

SCART AMP

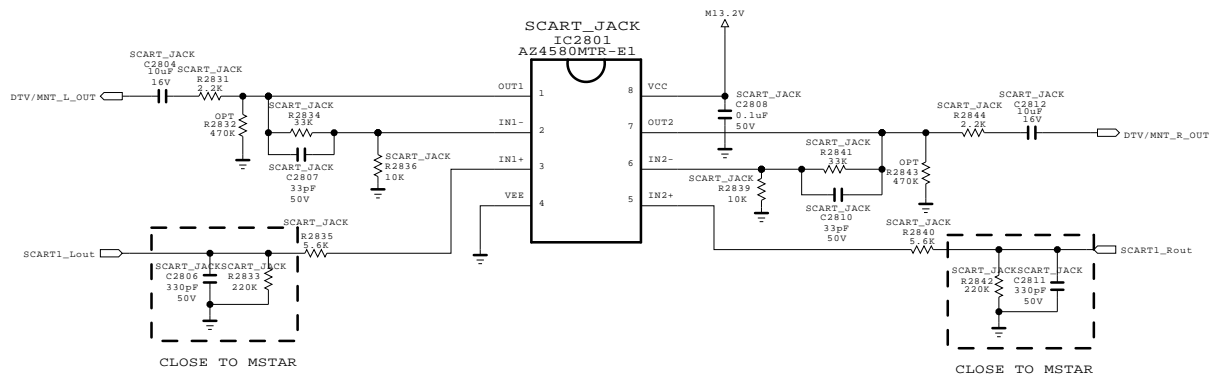

M13.2V FET

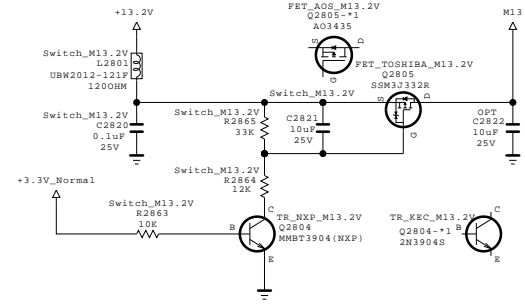

FULL SCART

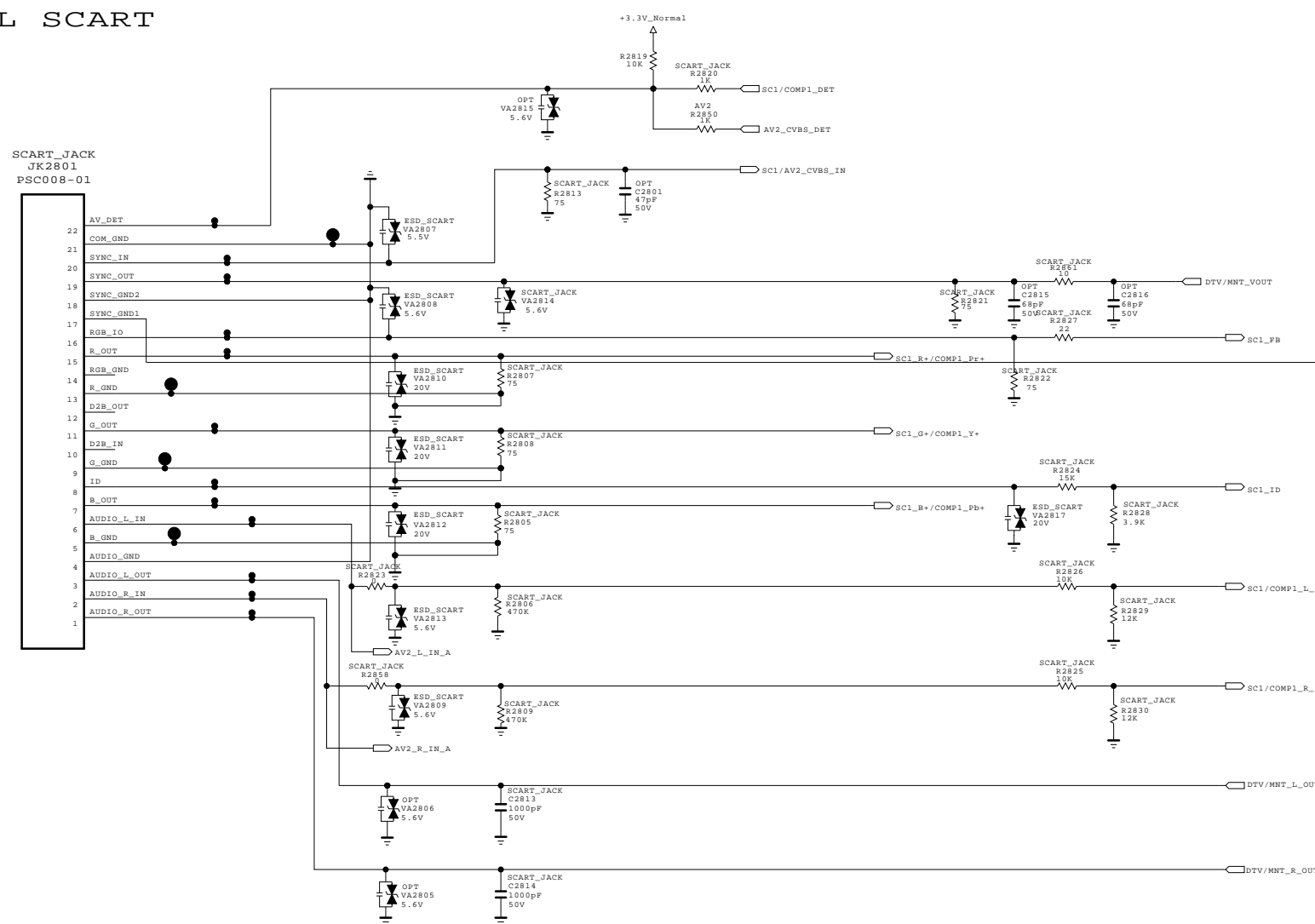

[SCART AUDIO MUTE]

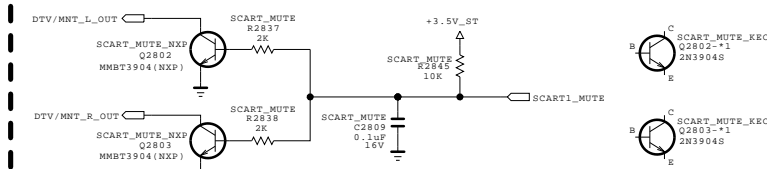

AV2

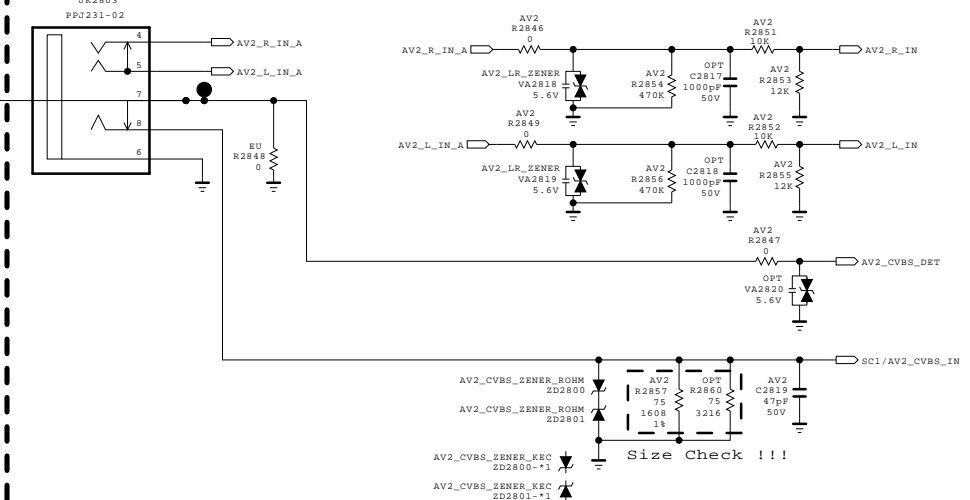

THE SYMBOL MARK OF THIS SCHEMATIC DIAGRAM INCORPORATES SPECIAL FEATURES IMPORTANT FOR PROTECTION FROM X-RADIATION. FIRE AND ELECTRICAL SHOCK HAZARDS, WHEN SERVICING IF IS ESSENTIAL THAT ONLY MANUFACTURERS SPECIFIED PARTS BE USED FOR THE CRITICAL COMPONENTS IN THE SYMBOL MARK OF THE SCHEMATIC.

SECRET
LGElectronics



MODEL	L14_CA_M1A	DATE	2014/11/21
BLOCK	SCART_COMPONENT	SHEET	28

Headphone

*Option : HEAD_PHONE_EU

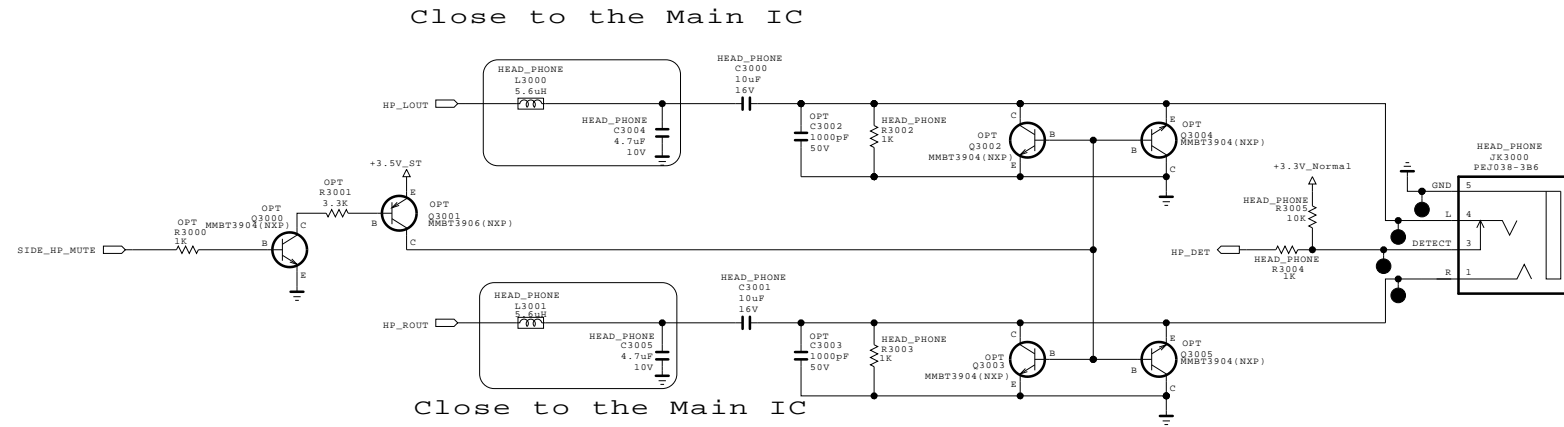

THE SYMBOL MARK OF THIS SCHEMATIC DIAGRAM INCORPORATES SPECIAL FEATURES IMPORTANT FOR PROTECTION FROM X-RADIATION, FIRE AND ELECTRICAL SHOCK HAZARDS, WHEN SERVICING IF IS ESSENTIAL THAT ONLY MANUFACTURERS SPECIFIED PARTS BE USED FOR THE CRITICAL COMPONENTS IN THE SYMBOL MARK OF THE SCHEMATIC.

SECRET
LGElectronics



MODEL	L14_CA_M1A	DATE	2014/05/22
BLOCK	HEAD_PHONE	SHEET	30 /

L14 TUNER_EU T/C_T2/C/S2_CHINA

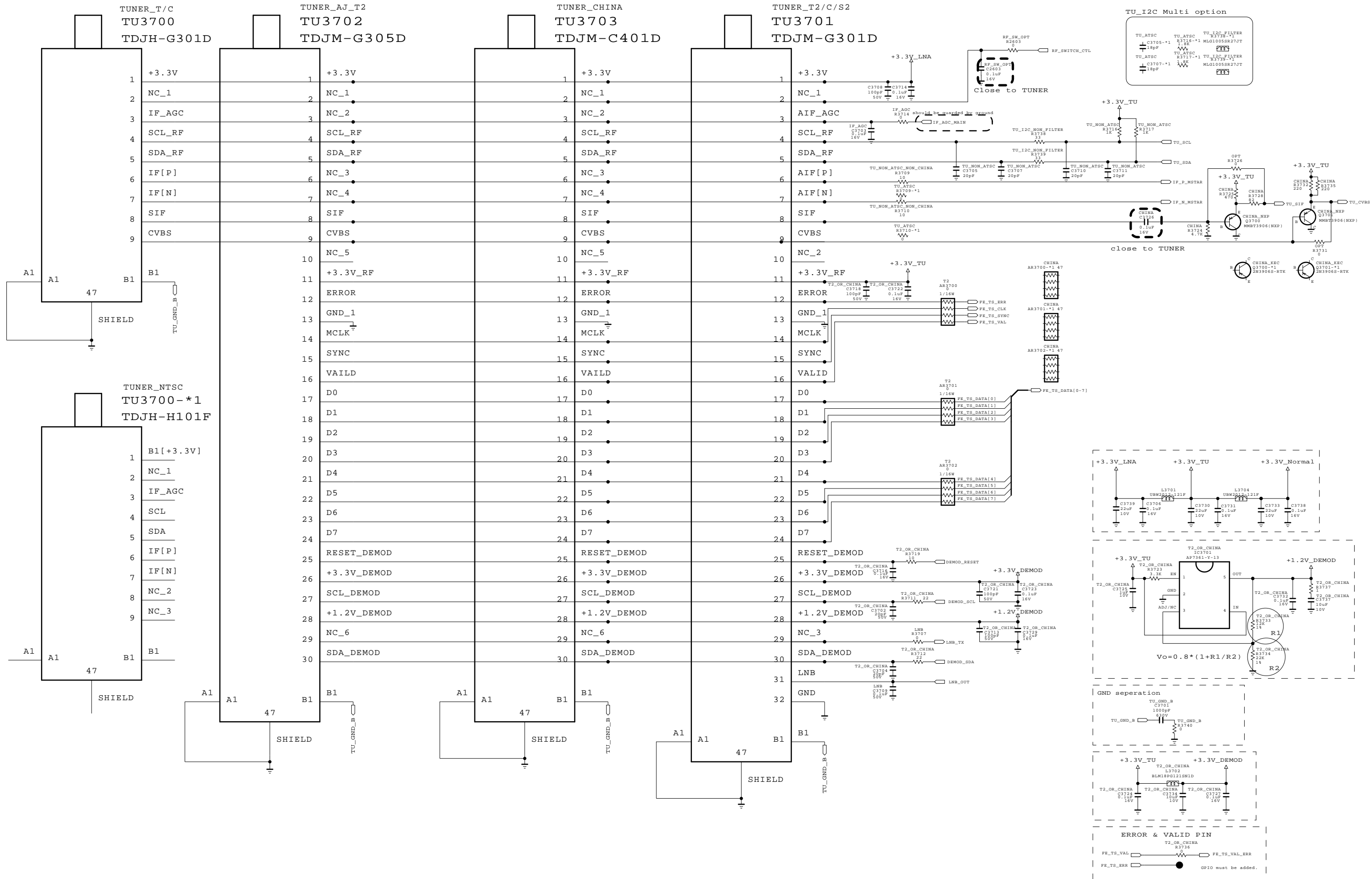

THE Δ SYMBOL MARK OF THIS SCHEMATIC DIAGRAM INCORPORATES SPECIAL FEATURES IMPORTANT FOR PROTECTION FROM X-RADIATION, FIRE AND ELECTRICAL SHOCK HAZARDS, WHEN SERVICING IF IS ESSENTIAL THAT ONLY MANUFACTURERS SPECIFIED PARTS BE USED FOR THE CRITICAL COMPONENTS IN THE Δ SYMBOL MARK OF THE SCHEMATIC.

SECRET
LGElectronics



MODEL	L14_CA_M1A	DATE	2014/05/22
BLOCK	TUNER_T2CS2	SHEET	37

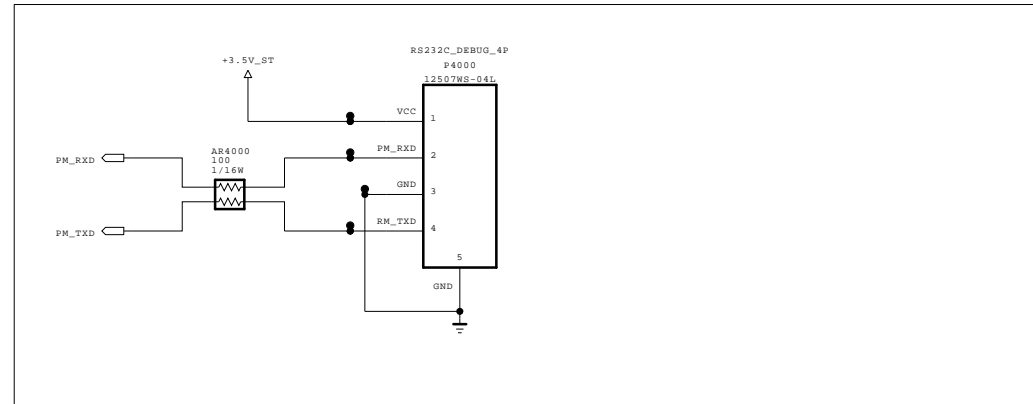

RS-232C 4PIN

RS-232C 4PIN

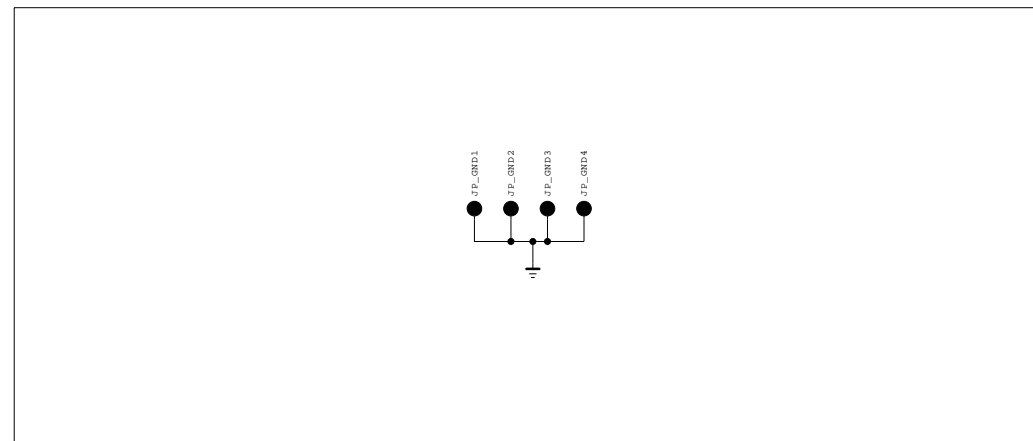

MSTAR DEBUG 4PIN



THE  SYMBOL MARK OF THIS SCHEMATIC DIAGRAM INCORPORATES SPECIAL FEATURES IMPORTANT FOR PROTECTION FROM X-RADIATION. FIRE AND ELECTRICAL SHOCK HAZARDS, WHEN SERVICING IF IS ESSENTIAL THAT ONLY MANUFACTURERS SPECIFIED PARTS BE USED FOR THE CRITICAL COMPONENTS IN THE  SYMBOL MARK OF THE SCHEMATIC.



SECRET
LGElectronics

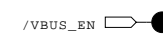
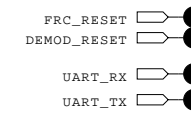
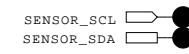
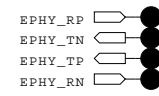
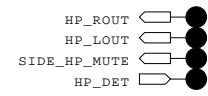
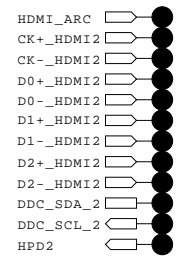
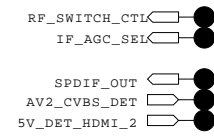

MODEL	L14_CA_M1A	DATE	2014/05/22
BLOCK	RS232C_MSTAR_DEBUG_4P	SHEET	40 /

TP for EU



THE  SYMBOL MARK OF THIS SCHEMATIC DIAGRAM INCORPORATES SPECIAL FEATURES IMPORTANT FOR PROTECTION FROM X-RADIATION. FIRE AND ELECTRICAL SHOCK HAZARDS, WHEN SERVICING IF IS ESSENTIAL THAT ONLY MANUFACTURERS SPECIFIED PARTS BE USED FOR THE CRITICAL COMPONENTS IN THE  SYMBOL MARK OF THE SCHEMATIC.

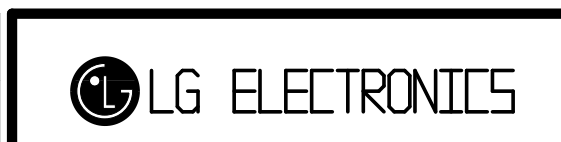

SECRET
LGElectronics

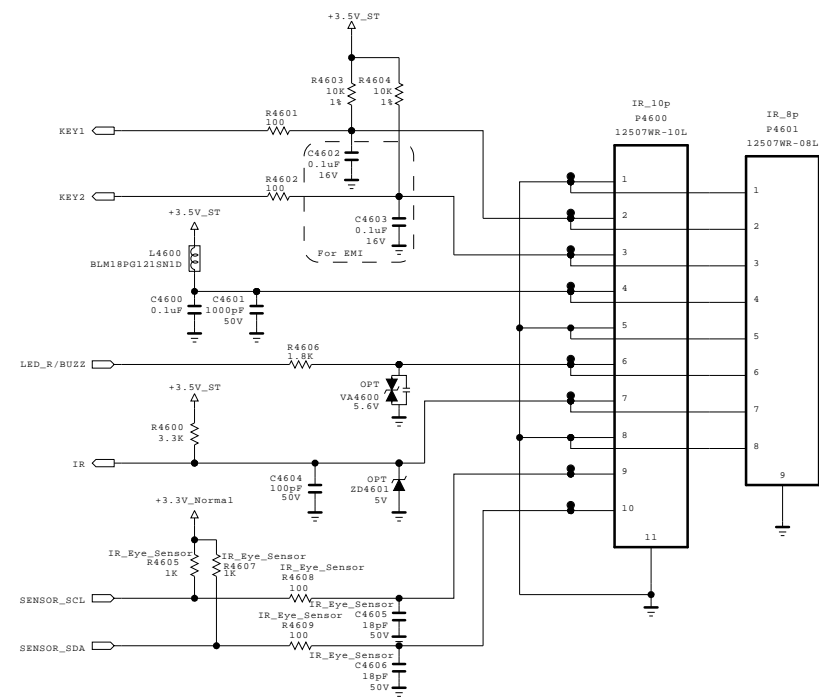

MODEL	L14_CA_M1A	DATE	2014/05/22
BLOCK	TP_EU	SHEET	41 /

IR + LED + Digital Eye + Control Key



THE  SYMBOL MARK OF THIS SCHEMATIC DIAGRAM INCORPORATES SPECIAL FEATURES IMPORTANT FOR PROTECTION FROM X-RADIATION, FIRE AND ELECTRICAL SHOCK HAZARDS, WHEN SERVICING IT IS ESSENTIAL THAT ONLY MANUFACTURERS SPECIFIED PARTS BE USED FOR THE CRITICAL COMPONENTS IN THE  SYMBOL MARK OF THE SCHEMATIC.

SECRET
LGElectronics



MODEL	L14_CA_M1A	DATE	2014/06/02
BLOCK	IR_EYE_SENSOR	SHEET	46 /

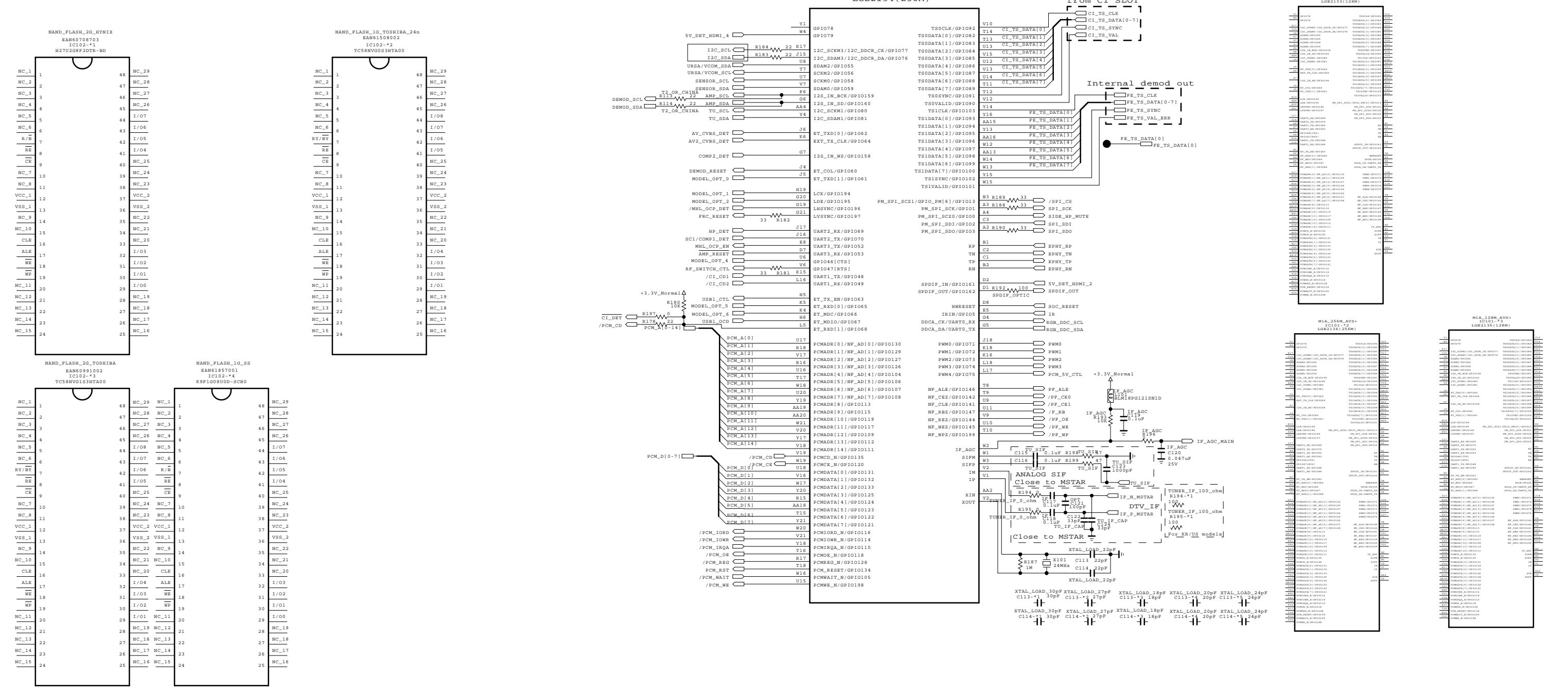
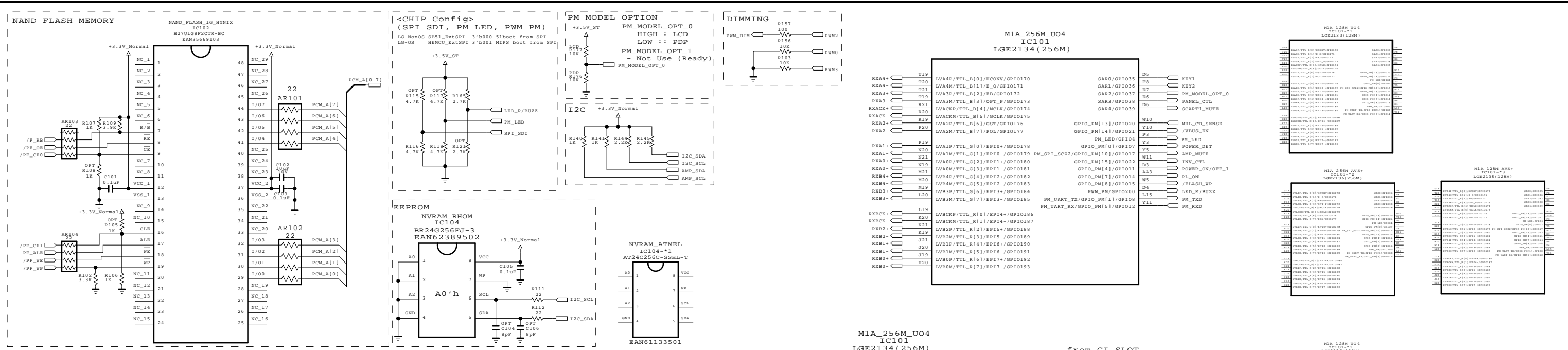

THE Δ SYMBOL MARK OF THIS SCHEMATIC DIAGRAM INCORPORATES SPECIAL FEATURES IMPORTANT FOR PROTECTION FROM X-RADIATION. FIRE AND ELECTRICAL SHOCK HAZARDS, WHEN SERVICING IF IS ESSENTIAL THAT ONLY MANUFACTURERS SPECIFIED PARTS BE USED FOR THE CRITICAL COMPONENTS IN THE Δ SYMBOL MARK OF THE SCHEMATIC.

SECRET
 LG Electronics



MODEL	L14_CA_M1A	DATE	2014/05/20
BLOCK	MAIN1_EU	SHEET	1

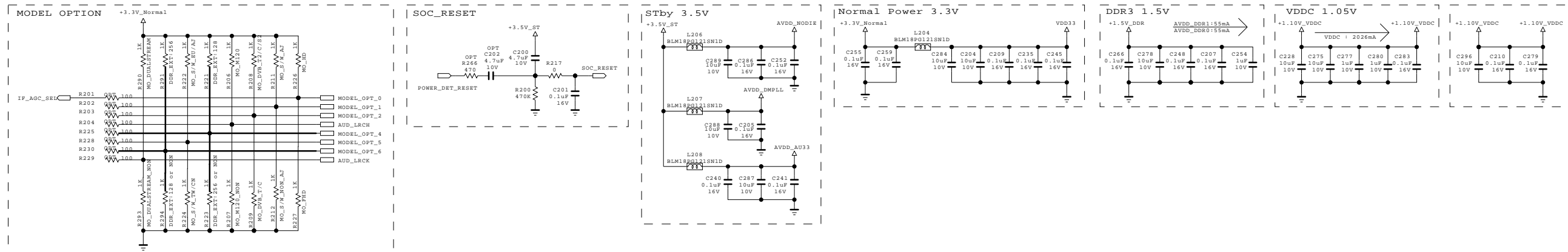

MODEL OPTION

PIN NAME	PIN NO	LOW	HIGH
MODEL_OPT_0	J5	MO_FHD	MO_HD
MODEL_OPT_1	H19	MO_S/W_NON_AJ	MO_S/W_AJ
MODEL_OPT_2	G20	MO_DVB_T/C	MO_DVB_T2/C/S2
AUD_LRCK	G19	MO_M120_NON	MO_M120
MODEL_OPT_4	U6	DDR_EXT:256 or NON	DDR_EXT : 128
MODEL_OPT_5	K5	MO_S/W_TW/CN	MO_S/W_EU/AJ
MODEL_OPT_6	K4	DDR_EXT:128 or NON	DDR_EXT : 256
AUD_LRCK	L5	MO_DUALSTREAM_NON	MO_DUALSTREAM

* Dual Stream is only Korea 3D spec

Memory Option

Memory	Auto Det	MODEL_OPT_4	MODEL_OPT_6
128M Only	0	0	0
256M Only	1	0	0
128M+128M	0	1	0
128M+256M	0	0	1
256M+256M	1	0	1

Country Option

	MODEL_OPT_1	MODEL_OPT_5
TW	0	0
EU	0	1
CN	1	0
AJ	1	1

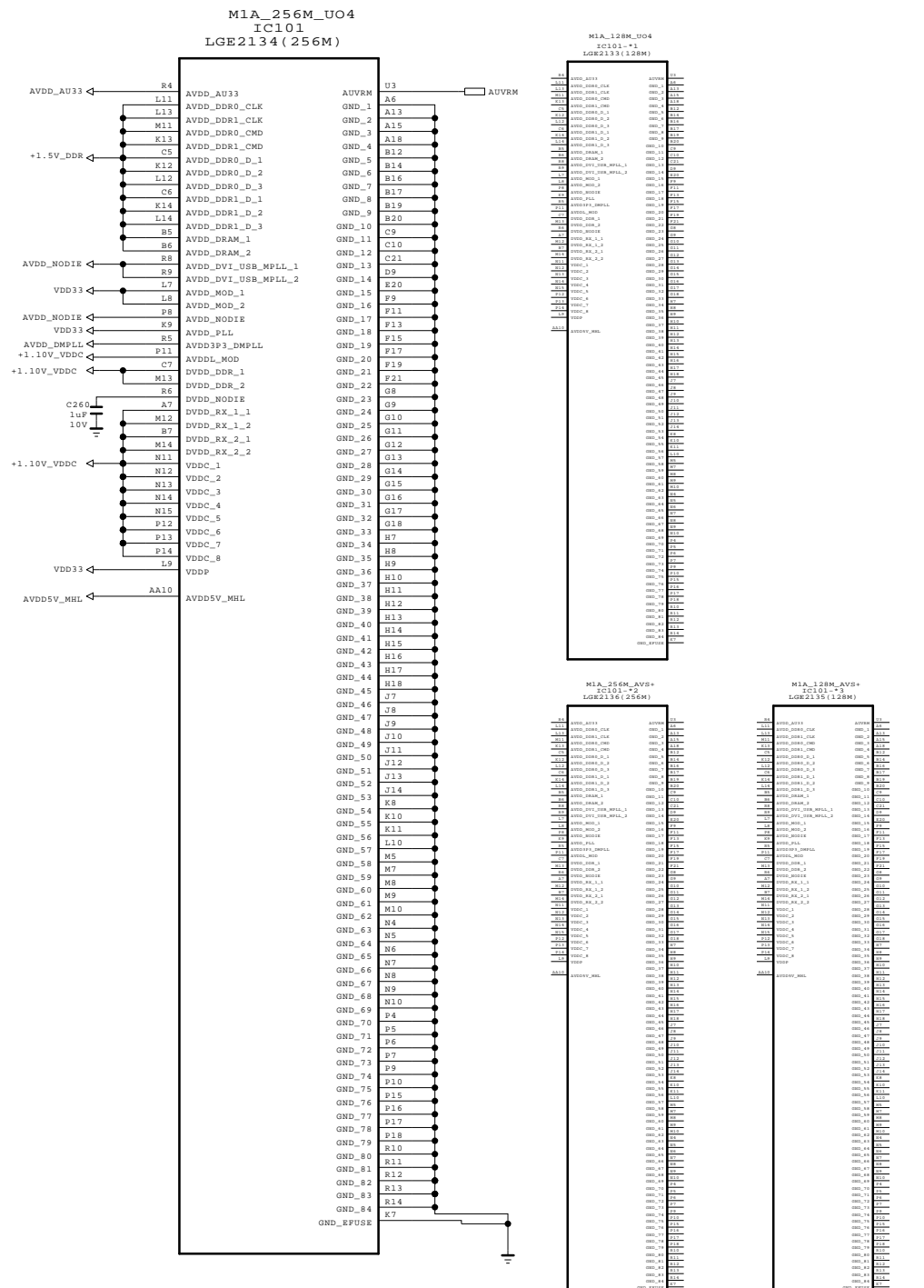
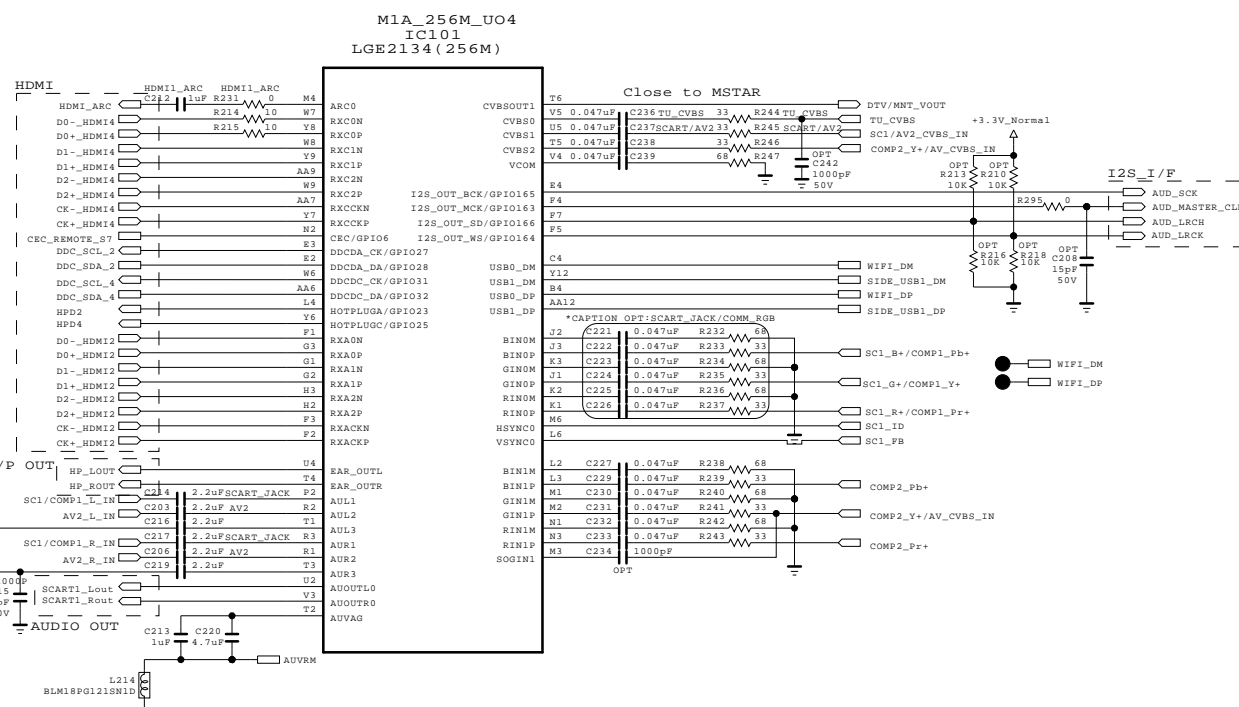

THE Δ SYMBOL MARK OF THIS SCHEMATIC DIAGRAM INCORPORATES SPECIAL FEATURES IMPORTANT FOR PROTECTION FROM X-RADIATION, FIRE AND ELECTRICAL SHOCK HAZARDS, WHEN SERVICING IF IS ESSENTIAL THAT ONLY MANUFACTURES SPECIFIED PARTS BE USED FOR THE CRITICAL COMPONENTS IN THE Δ SYMBOL MARK OF THE SCHEMATIC.

SECRET
LGElectronics



MODEL	L14_CA_M1A	DATE	2014/11/18
BLOCK	MAIN2_EU	SHEET	2

AUDIO AMP (TI)

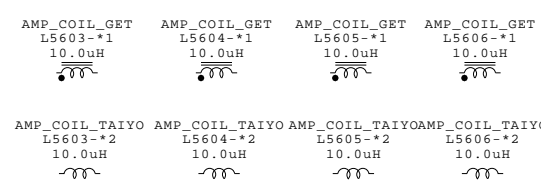
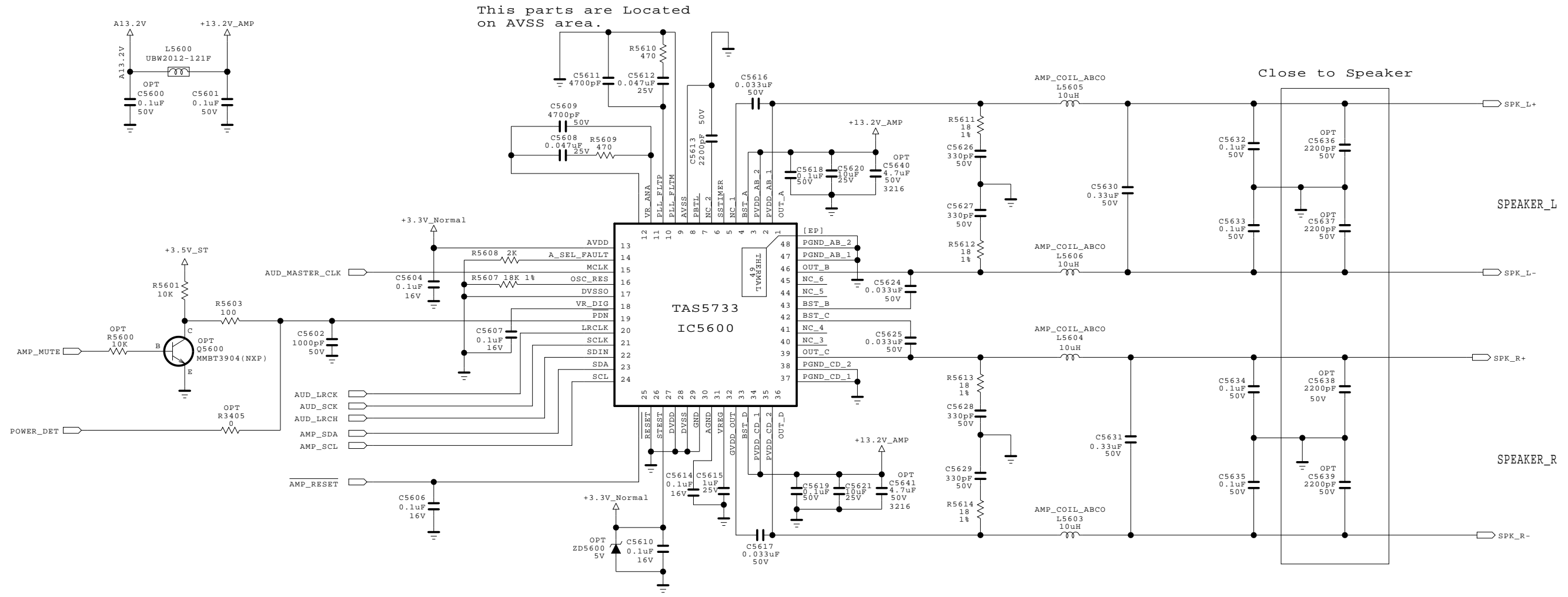

Close to Speaker

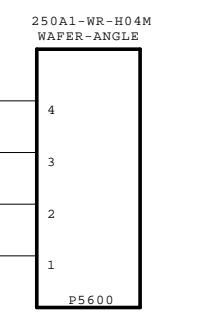

Box Type SPK Wafer

THE ⚠ SYMBOL MARK OF THIS SCHEMATIC DIAGRAM INCORPORATES SPECIAL FEATURES IMPORTANT FOR PROTECTION FROM X-RADIATION. FIRE AND ELECTRICAL SHOCK HAZARDS, WHEN SERVICING IF IS ESSENTIAL THAT ONLY MANUFACTURES SPECIFIED PARTS BE USED FOR THE CRITICAL COMPONENTS IN THE ⚠ SYMBOL MARK OF THE SCHEMATIC.

SECRET	LG ELECTRONICS
LGElectronics	

MODEL	L14_CA_AMP	DATE	140818
BLOCK	1AMP_TAS	SHEET	56 /

MHL SW AND GATE

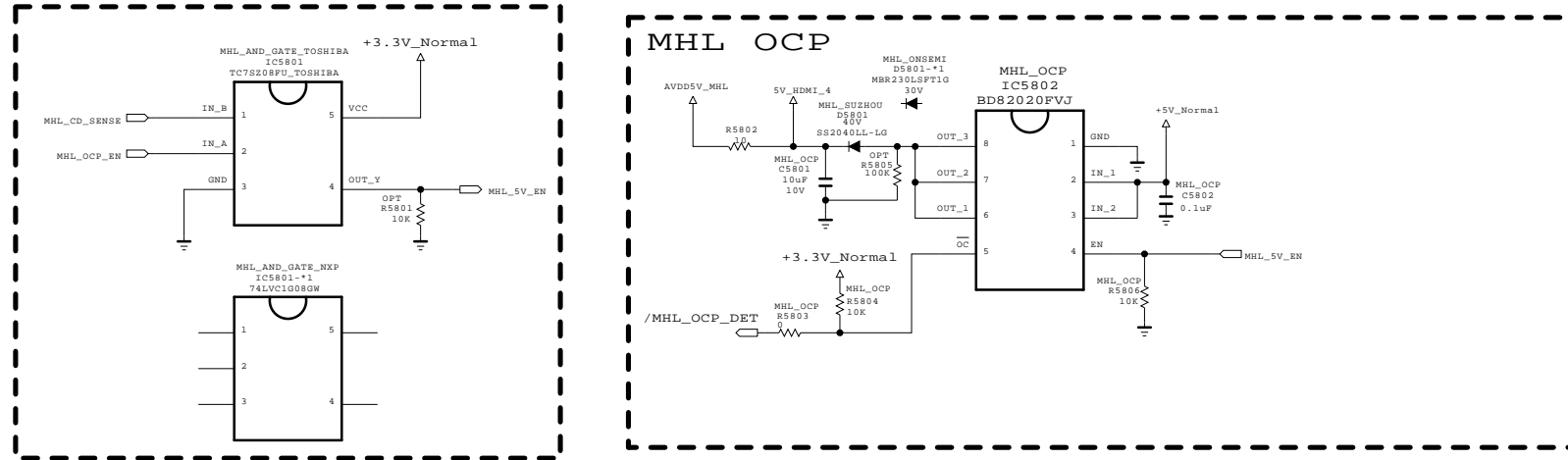

THE SYMBOL MARK OF THIS SCHEMATIC DIAGRAM INCORPORATES SPECIAL FEATURES IMPORTANT FOR PROTECTION FROM X-RADIATION. FIRE AND ELECTRICAL SHOCK HAZARDS, WHEN SERVICING IF IS ESSENTIAL THAT ONLY MANUFACTURERS SPECIFIED PARTS BE USED FOR THE CRITICAL COMPONENTS IN THE SYMBOL MARK OF THE SCHEMATIC.

SECRET
LGElectronics



MODEL	L14_CA_M1A	DATE	140815
BLOCK	MHL_SW_AND	SHEET	58 /



L15 Repair Process

Contents of Standard Repair Process

* First of all, Check whether there is SVC Bulletin in GCSC System for these model.

No.	Error symptom (High category)	Error symptom (Mid category)	Page	Remarks
1	A. Video error	No video/Normal audio	1	
2		No video/No audio	2	
3		Tuning fail, Picture broken/ Freezing	3, 4	
4		Color error	5	
5		Vertical/Horizontal bar, residual image, light spot, external device color error	6	
6	B. Power error	No power	7	
7		Off when on, off while viewing, power auto on/off	8	
8	C. Audio error	No audio/Normal video	9	
9		Wrecked audio/discontinuation/noise	10	
10	D. Function error	Remote control & Local switch checking	11	
11		External device recognition error	12	
12	E. Noise	Circuit noise, mechanical noise	13	
13	F. Exterior error	Exterior defect	14	

Error symptom	A. Video error	Established date	
	No video / Normal audio	Revised date	1/14

First of all, Check whether all of cables between board is inserted properly or not.
(Main B/D ↔ Power B/D, LVDS Cable, Speaker Cable, IR B/D Cable...)

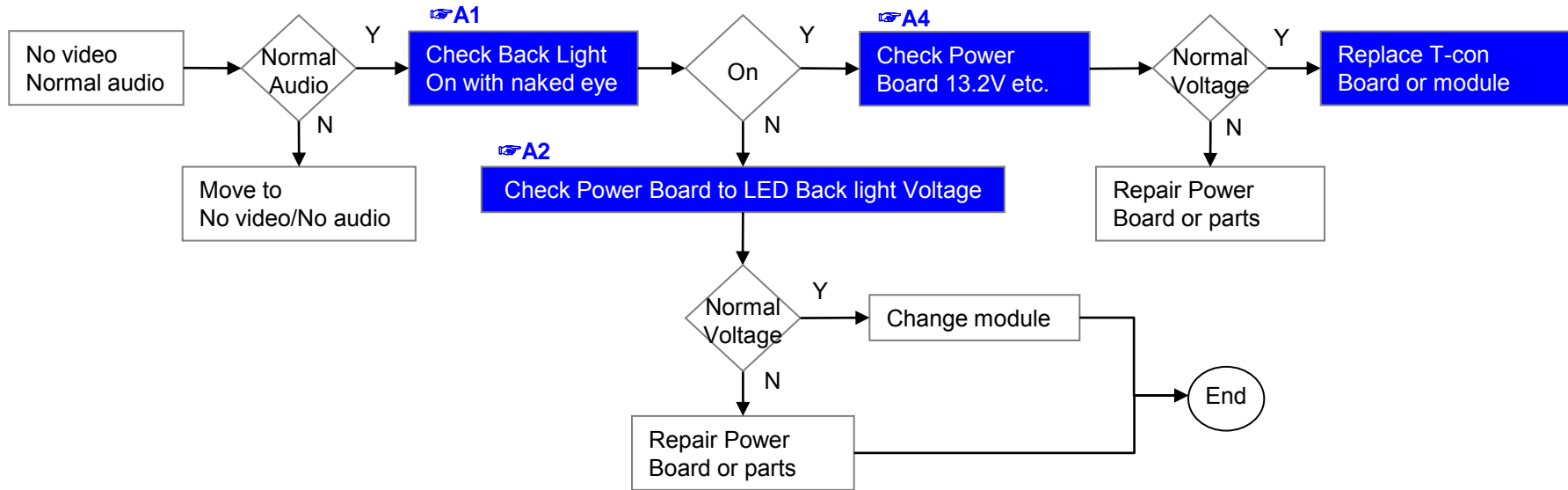

※ Precaution **A6 & A3**

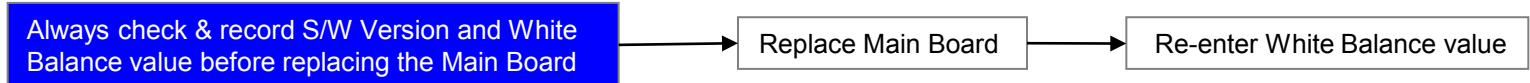

Error symptom	A. Video error	Established date		
	No video / No audio	Revised date		2/14

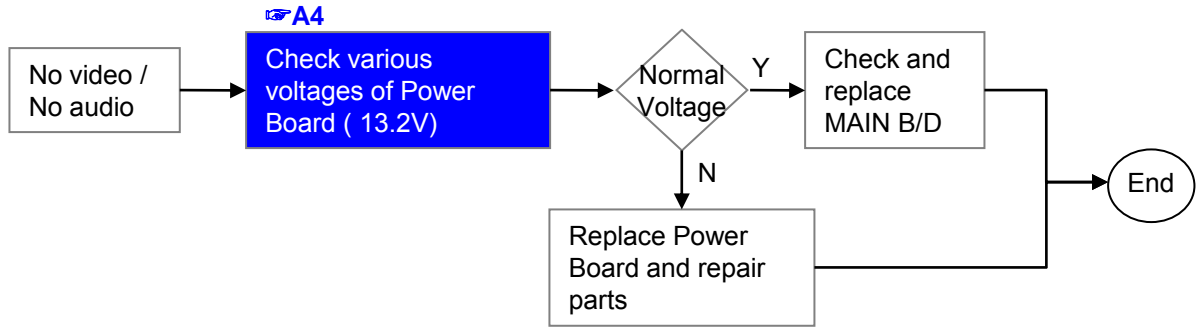

A. Video error

Established date

Error symptom

Tuning fail, Picture broken/ Freezing

Revised date

3/14

A5

Check RF Signal level

- . By using Digital signal level meter
- . By using Diagnostics menu on OSD
(Menu → Customer Support(red button on remote control) → Signal Test)
- Signal strength (Normal : over 50%)
- Signal quality (Normal : over 50%)

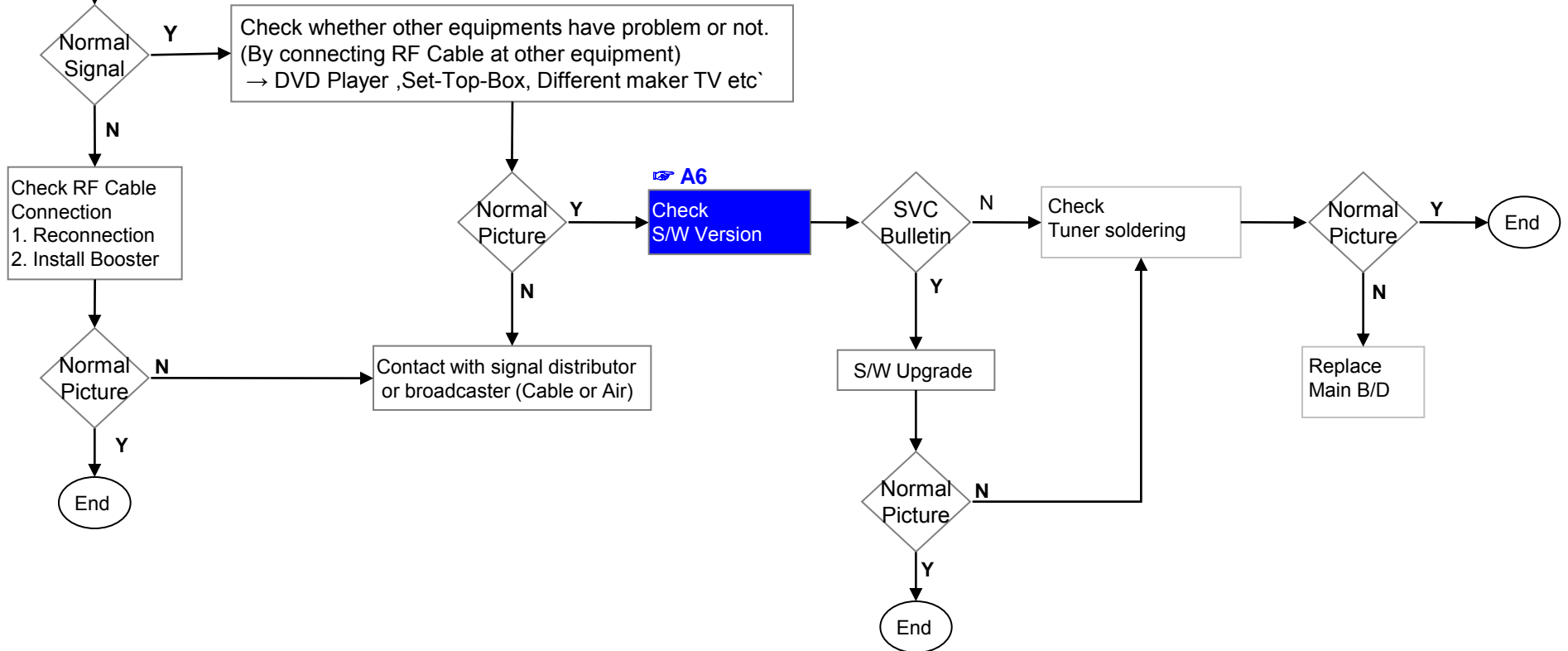

Error symptom	A. Video error	Established date		
	Tuning fail, Picture broken/ Freezing	Revised date		4/14

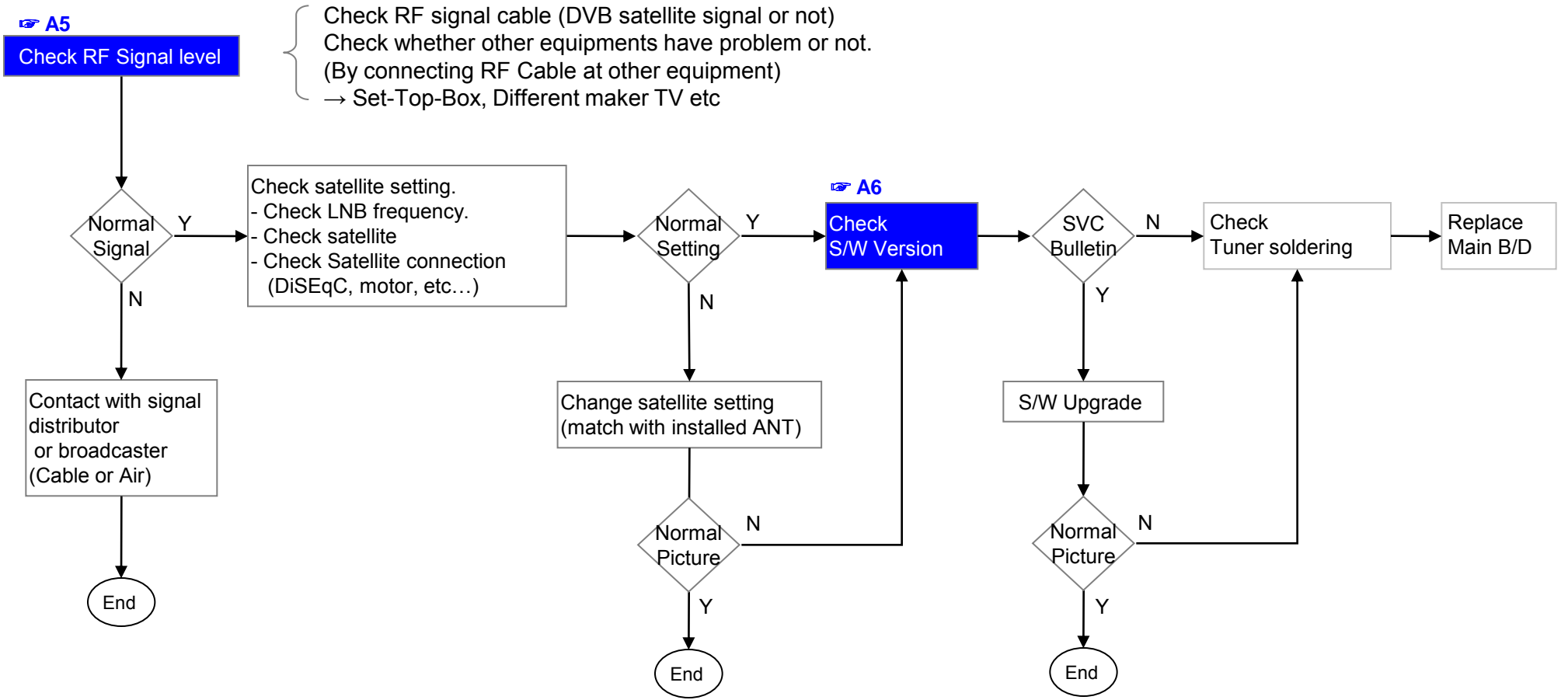

Error symptom	A. Video error	Established date		
	Color error	Revised date		5/14

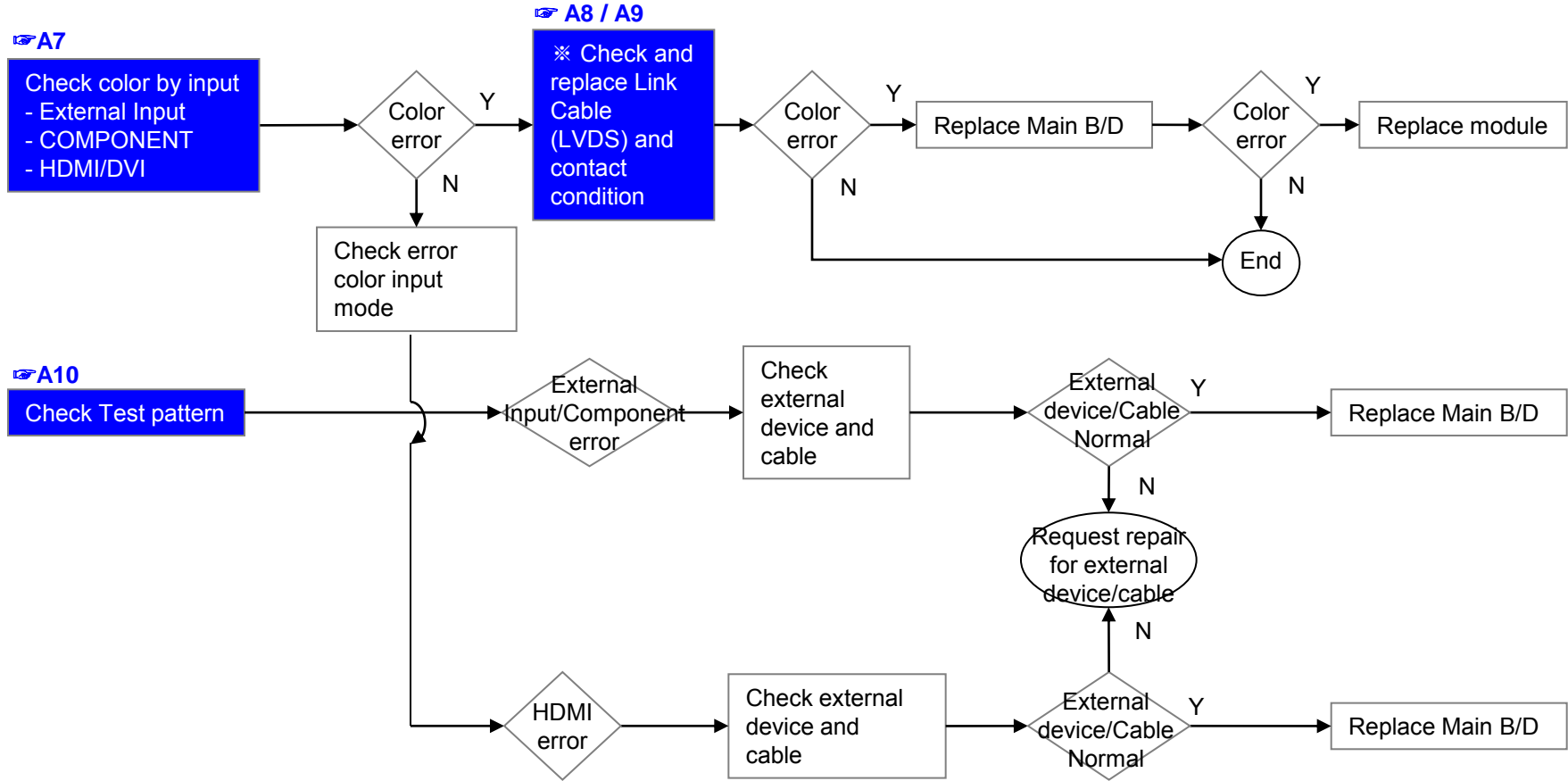

A. Video error

Established date

Revised date

6/14

Error symptom

Vertical / Horizontal bar, residual image, light spot, external device color error

Vertical/Horizontal bar, residual image, light spot

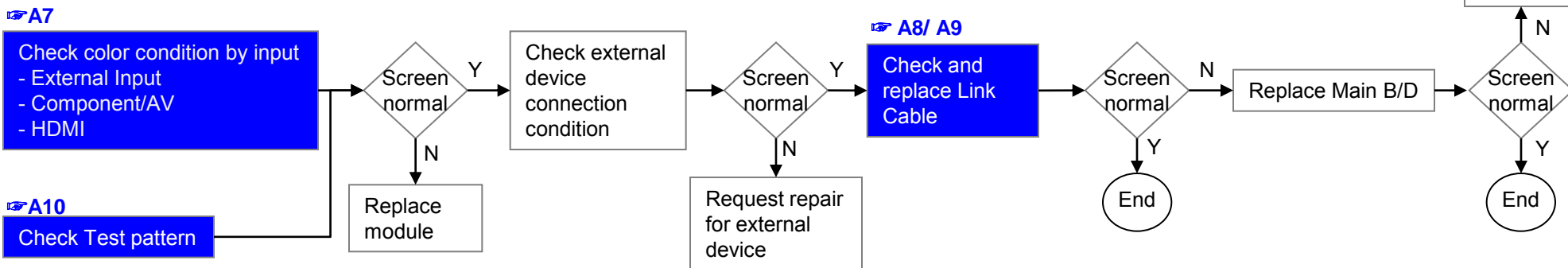

External device screen error-Color error

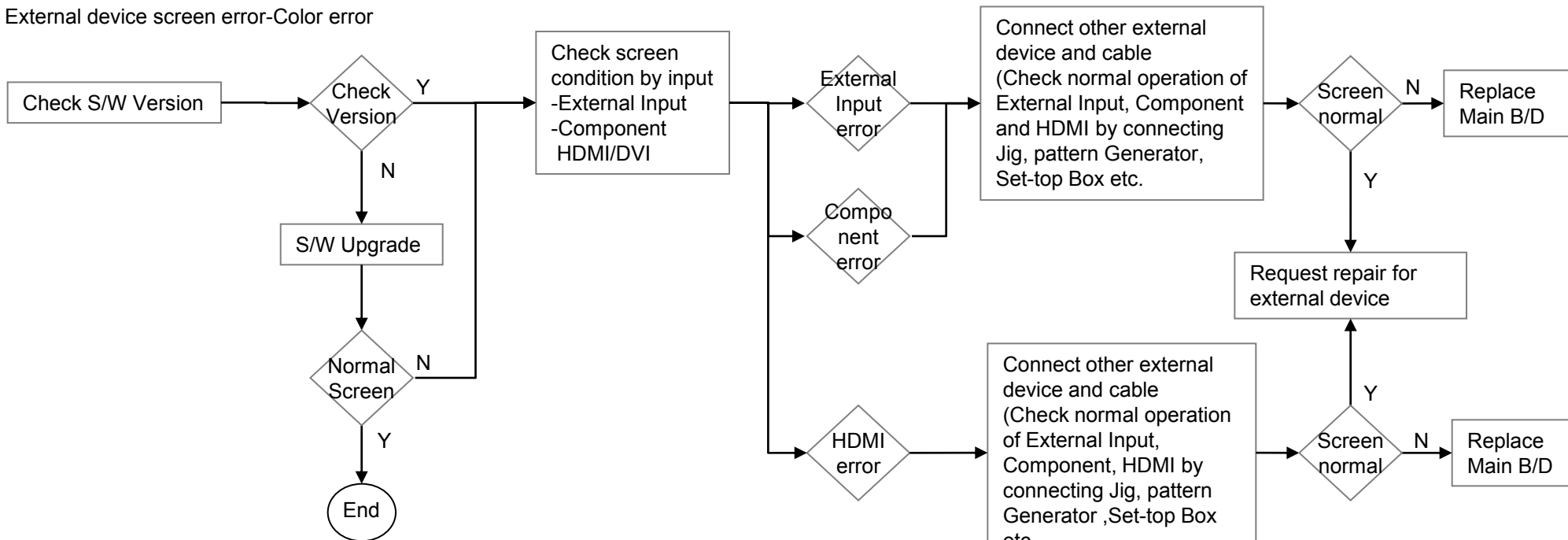

B. Power error

Established date

Revised date

7/14

Error symptom

No power

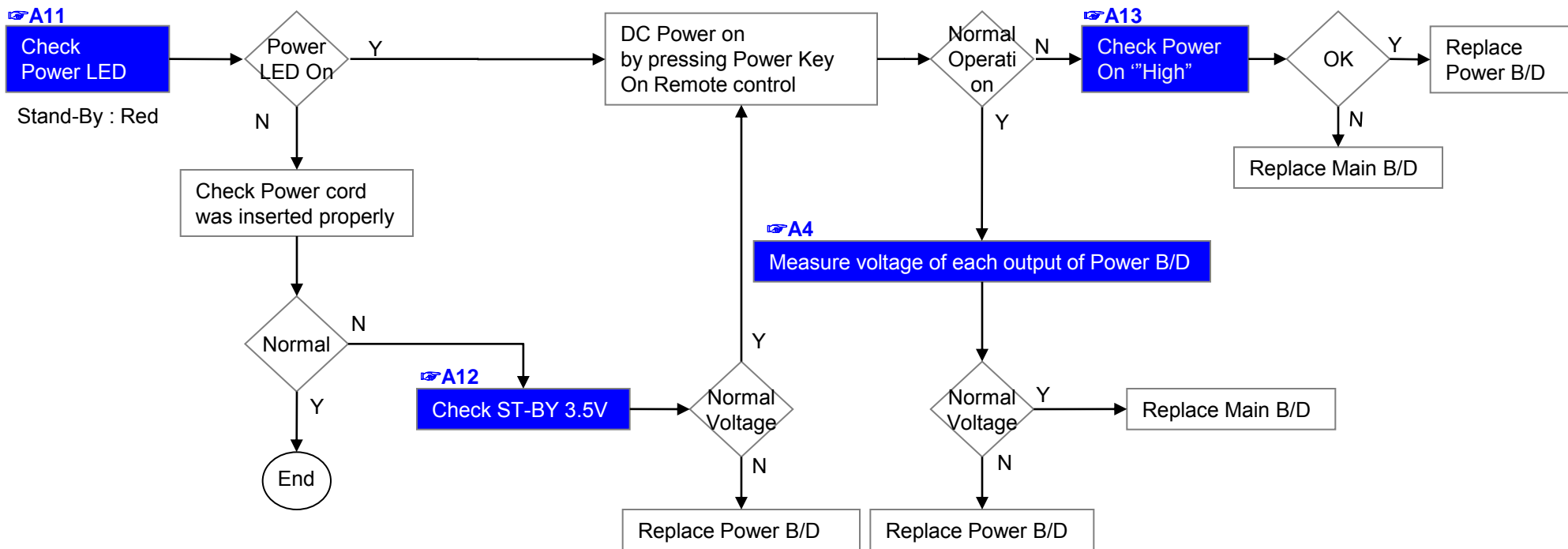

B. Power error

Established date

Revised date

8/14

Error symptom

Off when on, off while viewing, power auto on/off

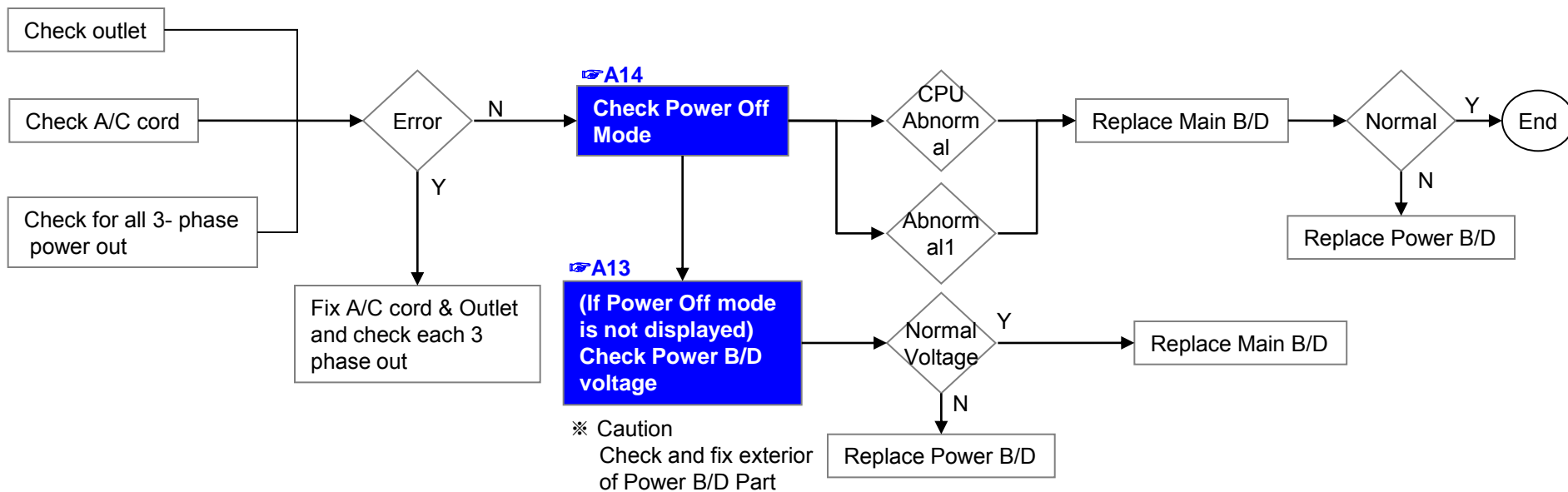

* Please refer to the all cases which can be displayed on power off mode.

Status	Power off List	Explanation
Normal	"POWEROFF_REMOTEKEY"	Power off by REMOTE CONTROL
	"POWEROFF_OFFTIMER"	Power off by OFF TIMER
	"POWEROFF_SLEEPTIMER"	Power off by SLEEP TIMER
	"POWEROFF_INSTOP"	Power off by INSTOP KEY
	"POWEROFF_AUTOOFF"	Power off by AUTO OFF
	"POWEROFF_ONTIMER"	Power off by ON TIMER
	"POWEROFF_RS232C"	Power off by RS232C
	"POWEROFF_RESREC"	Power off by Reserved Record
	"POWEROFF_RECEND"	Power off by End of Recording
	"POWEROFF_SWDOWN"	Power off by S/W Download
Abnormal	"POWEROFF_UNKNOWNN"	Power off by unknown status except listed case
	"POWEROFF_ABNORMAL1"	Power off by abnormal status except CPU trouble
	"POWEROFF_CPUABNORMAL"	Power off by CPU Abnormal

Error symptom	C. Audio error	Established date		
	No audio/ Normal video	Revised date		9/14

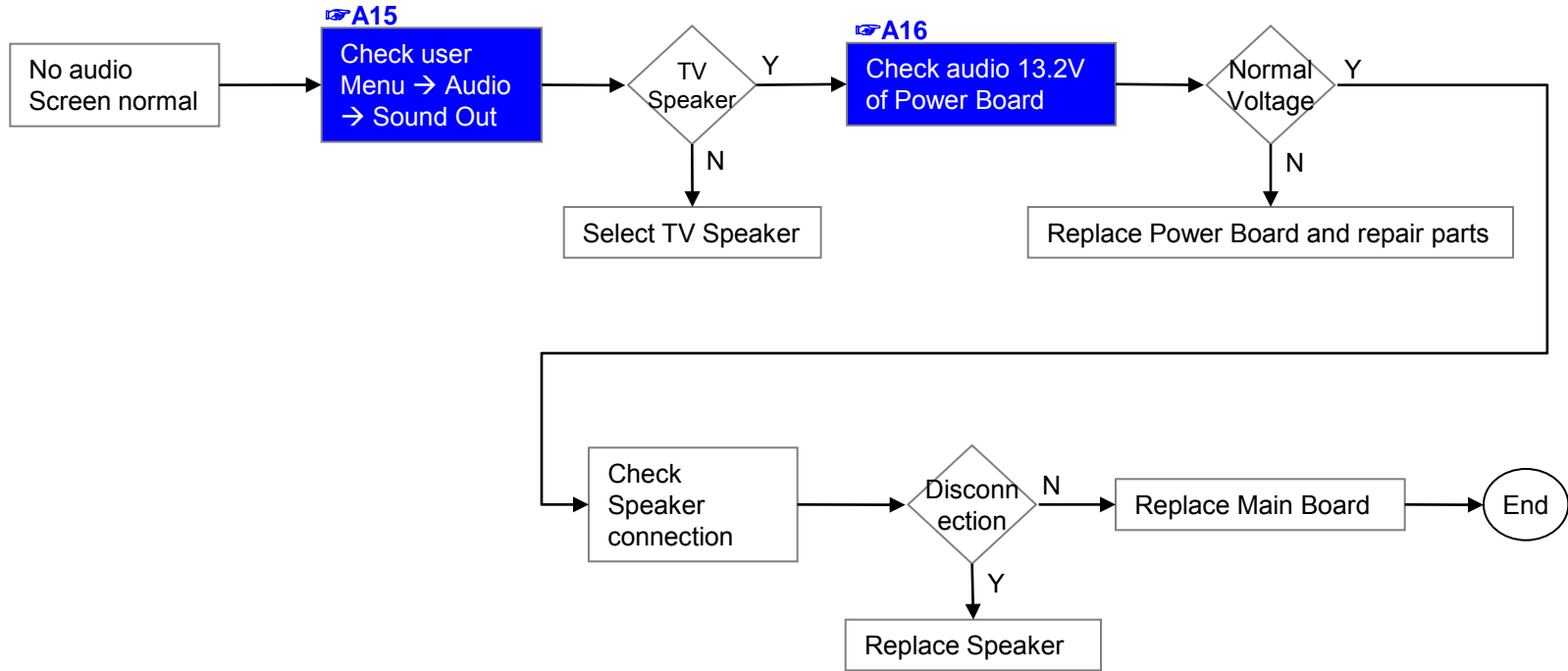

C. Audio error

Established date

Revised date

10/14

Error symptom

Wrecked audio / discontinuation / noise

→ abnormal audio/discontinuation/noise is same after “Check input signal” compared to No audio

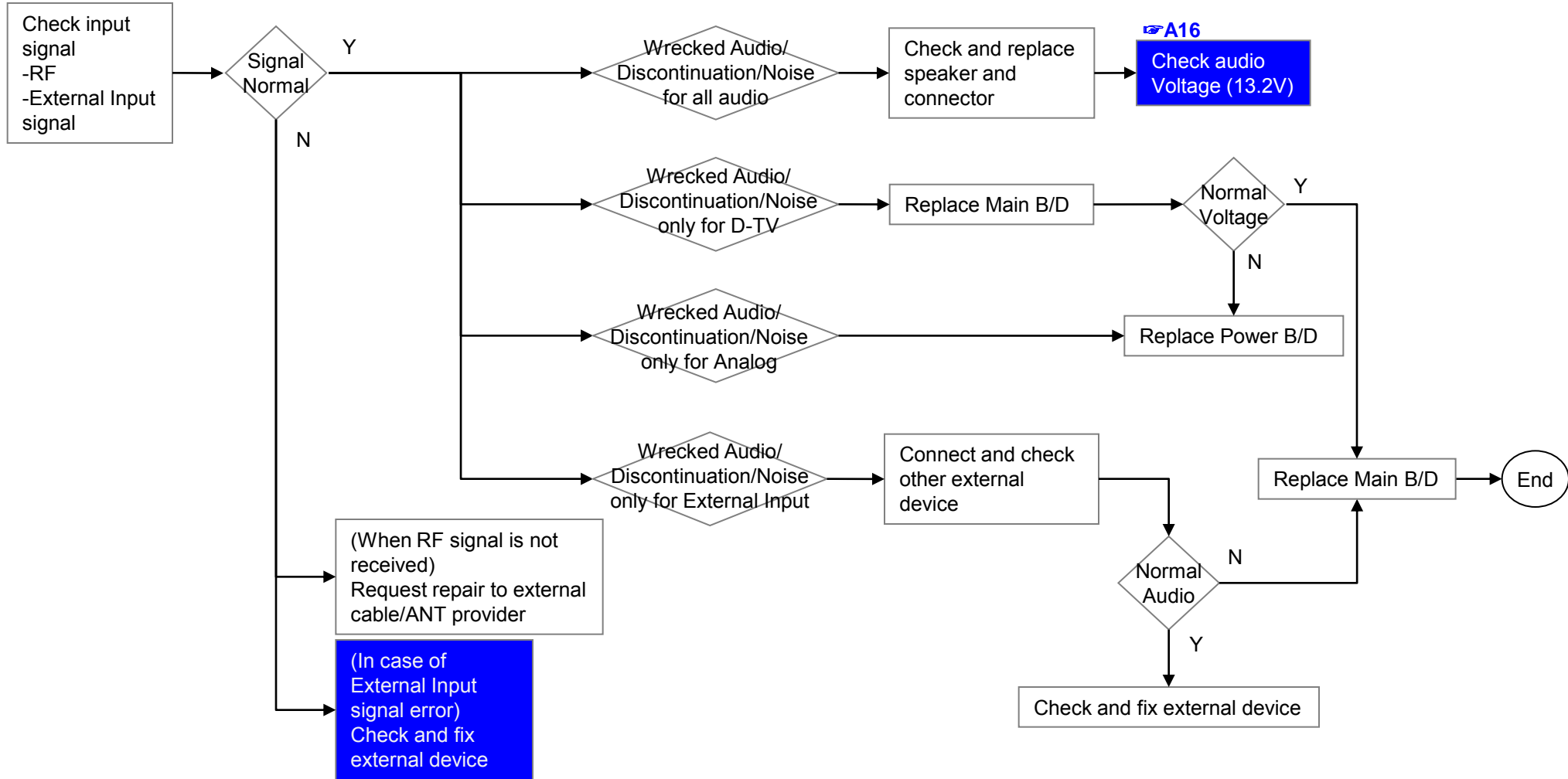

Error symptom	D. Function error	Established date		
	Remote control & Local switch checking	Revised date		11/14

Remote control(R/C) operating error

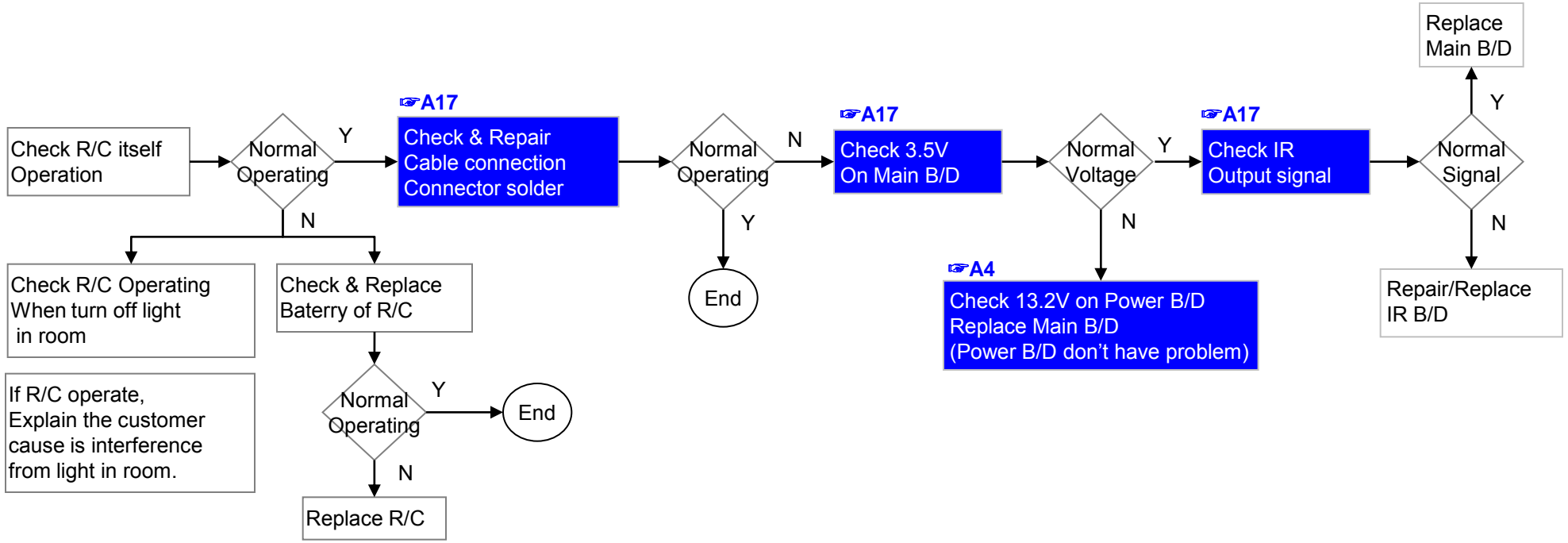

Error symptom	D. Function error	Established date	
	External device recognition error	Revised date	12/14

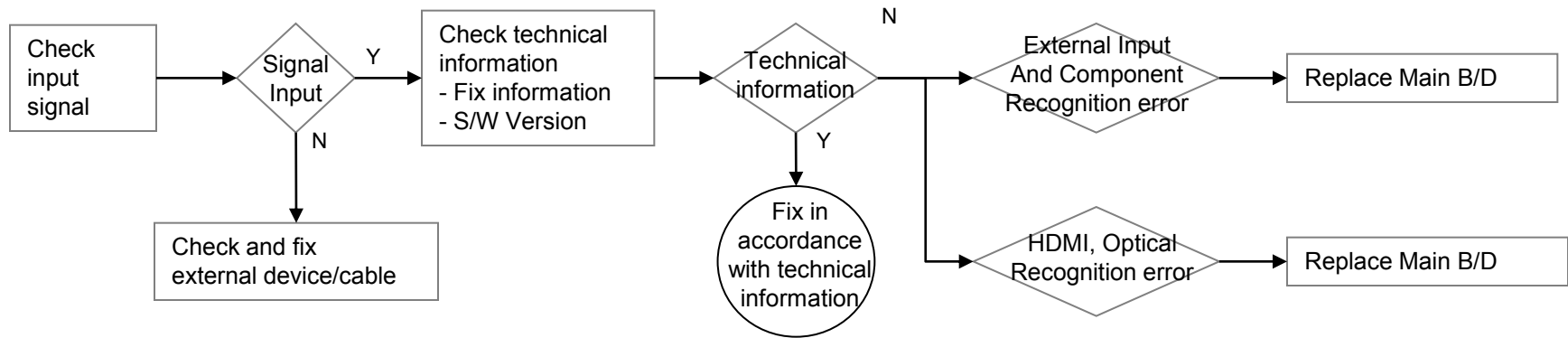

Error symptom	E. Noise	Established date		
	Circuit noise, mechanical noise	Revised date		13/14

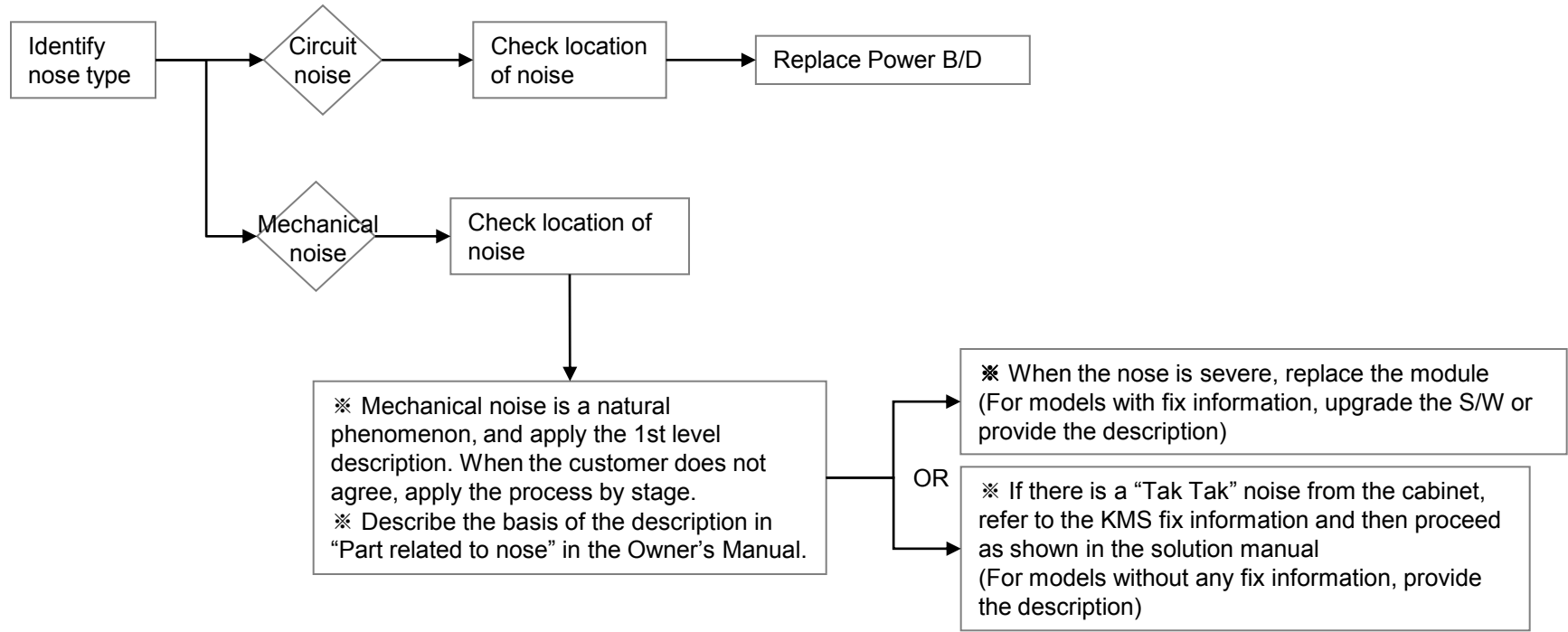

Error symptom	F. Exterior defect	Established date		
	Exterior defect	Revised date		14/14

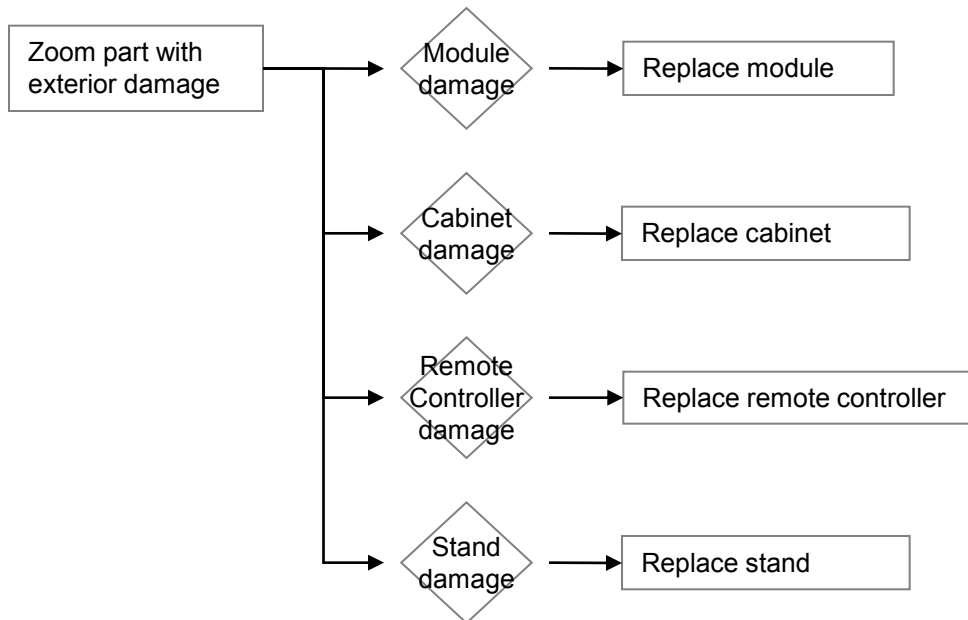

Contents of Standard Repair Process Detail Technical Manual

No.	Error symptom	Content	Page	Remarks
1	A. Video error_ No video/Normal audio	Check LCD back light with naked eye	A1	
2		LED driver B+ 24V measuring method	A2	
3		Check White Balance value	A3	
4		Power Board voltage measuring method	A4	
6	A. Video error_ No video/Video lag/stop	TUNER input signal strength checking method	A5	
7		Version checking method	A6	
9	A. Video error_Color error	Connection diagram	A7	
10		Check Link Cable (LVDS) reconnection condition	A8	
11			A9	
12		Adjustment Test pattern - ADJ Key	A10	
13	A. Video error_Vertical/Horizontal bar, residual image, light spot	Connection diagram	A8	
14		Check Link Cable (LVDS) reconnection condition	A8	
15			A9	
16	<Appendix> Defected Type caused by T-Con/ Inverter/ Module	Adjustment Test pattern - ADJ Key	A10	
17		Exchange T-Con Board (1)	A-1/5	
18		Exchange T-Con Board (2)	A-2/5	
19		Exchange LED driver Board (PSU)	A-3/5	
20		Exchange Module itself (1)	A-4/5	
		Exchange Module itself (2)	A-5/5	

Contents of Standard Repair Process Detail Technical Manual

No.	Error symptom	Content	Page	Remarks
21	B. Power error_No power	Check front display LED	A11	
22		Check power input Voltage & ST-BY 3.5V	A12	
23		Checking method when power is ON	A13	
24		POWER BOARD voltage measuring method	A4	
26	B. Power error_Off when on, off while viewing	POWER OFF MODE checking method	A14	
28	C. Audio error_No audio/Normal video	Checking method in menu when there is no audio	A15	
29		Voltage and speaker checking method when there is no audio	A16	
30	C. Audio error_Wrecked audio/discontinuation	Voltage and speaker checking method in case of audio error	A16	
31	D. Function error_ No response in remote controller, key error	Remote controller operation checking method	A17	

Standard Repair Process Detail Technical Manual

Error symptom	A. Video error_No video/Normal audio	Established date		
Content	Check Back Light On with naked eye	Revised date		A1

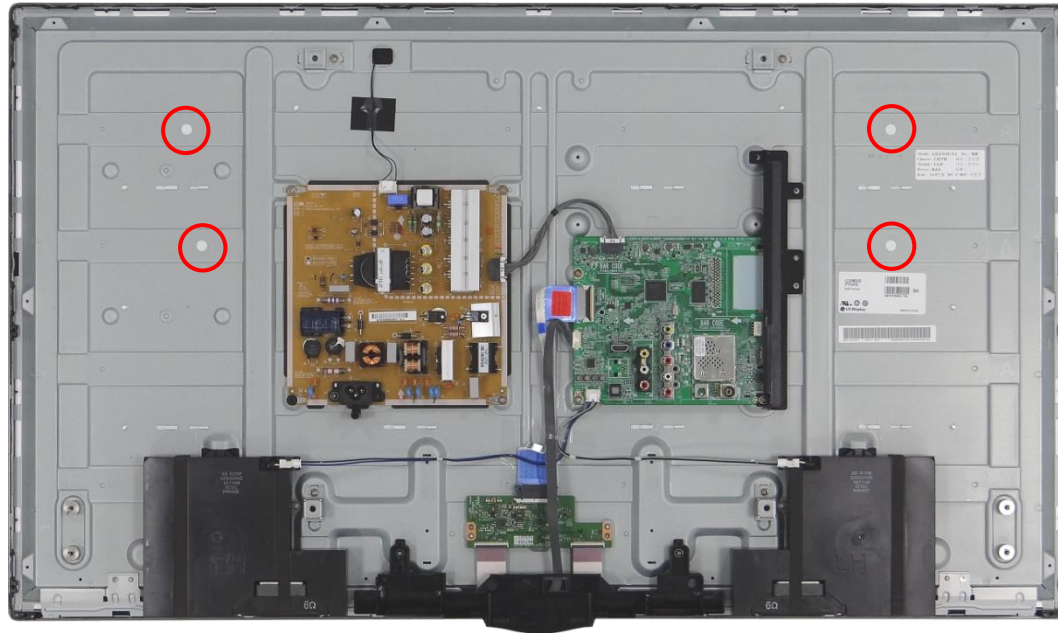

Power On -> disjoint back case -> check lighting

Standard Repair Process Detail Technical Manual

Error symptom	A. Video error_No video/Normal audio	Established date		
Content	Power Board to LED back light Voltage	Revised date		A2

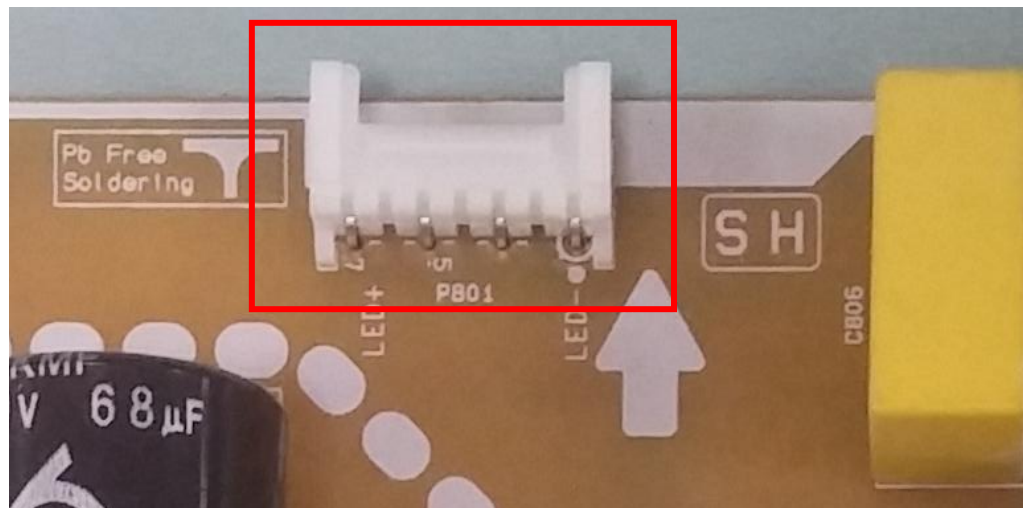

1. Measure DC Voltage applying to LED backlight from Power Board.
2. Output DC Voltage from Power Board -> supply to LED backlight.
Check Pin contacting statement and connection statement.

Standard Repair Process Detail Technical Manual

Error symptom	A. Video error_No video/Normal audio	Established date		
Content	Check White Balance value	Revised date		A3

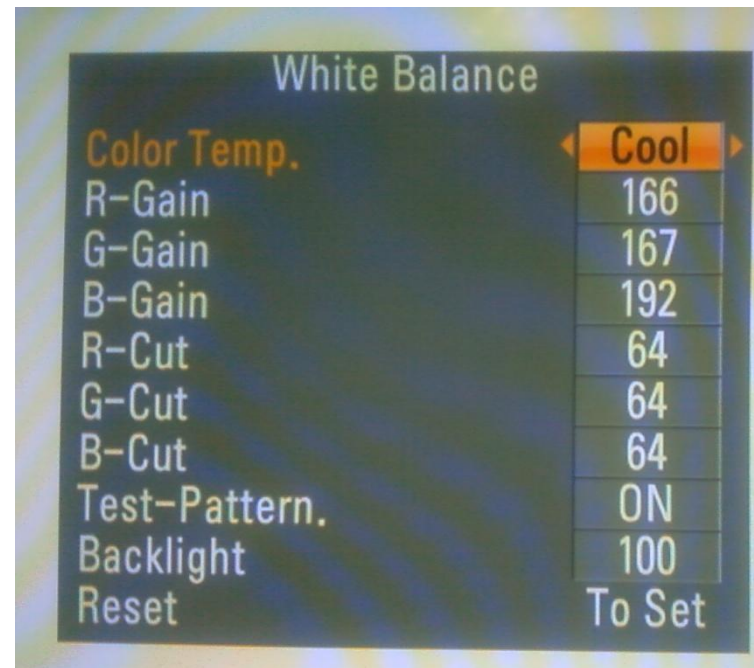
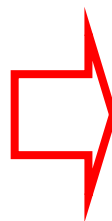
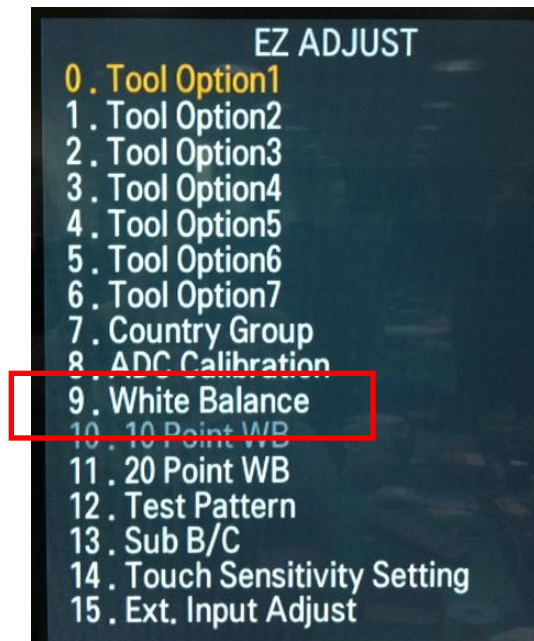

Entry method

1. Press the ADJ button on the remote controller for adjustment.
2. Enter into White Balance of item 9.
3. After recording the R, G, B (GAIN, Cut) value of Color Temp (Cool/Medium/Warm), re-enter the value after replacing the MAIN BOARD.

Standard Repair Process Detail Technical Manual

Error symptom	A. Video error_No video/ Audio	Established date		
Content	Power Board voltage measuring method	Revised date		A4

Check D.13.2V , A13.2V (4 ~8 PIN)

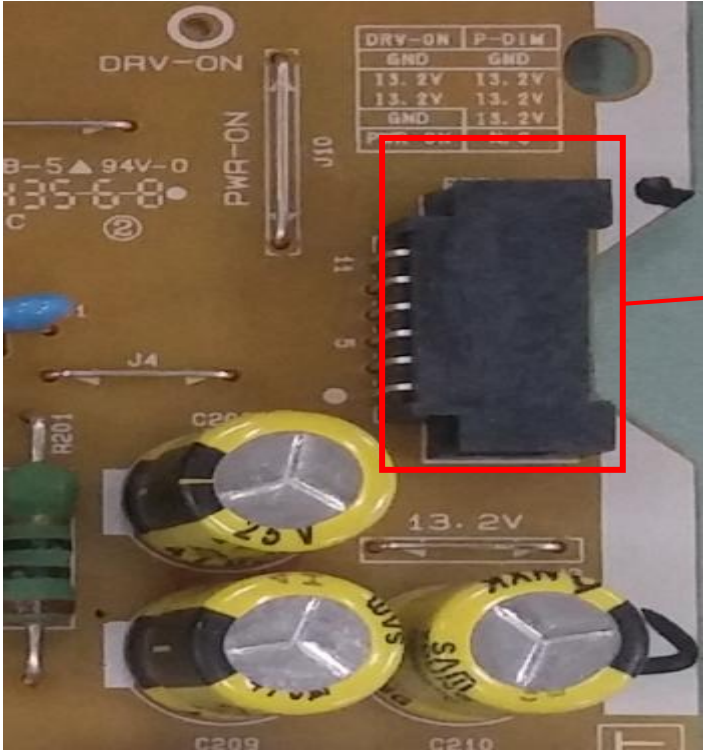

12 Pin (Power Board ↔ Main Board)			
SMH200-H12S4			
1	Power on	2	PDIM#2
3	GND	4	D.13.2V
5	D.13.2V	6	D.13.2V
7	A.13.2V	8	A.13.2V
9	GND	10	GND
11	DRV_ON	12	PDIM#1

Standard Repair Process Detail Technical Manual

Error symptom	A. Video error_Video error, video lag/stop	Established date		
Content	TUNER input signal strength checking method	Revised date		A5



MENU → Press red key Remote controller → signal test
 → Select channel



When the signal is strong, use the attenuator (-10dB, -15dB, -20dB etc.)

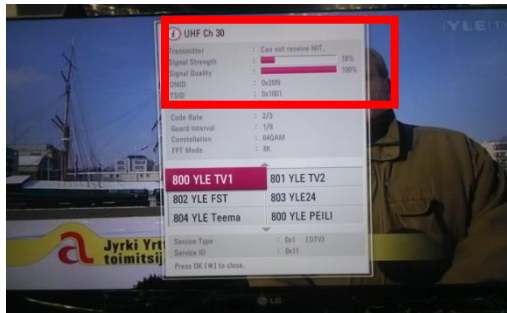

Standard Repair Process Detail Technical Manual

Error symptom	A. Video error_Video error, video lag/stop	Established date		
Content	LCD-TV Version checking method	Revised date		A6

Checking SW version method for remote controller for adjustment

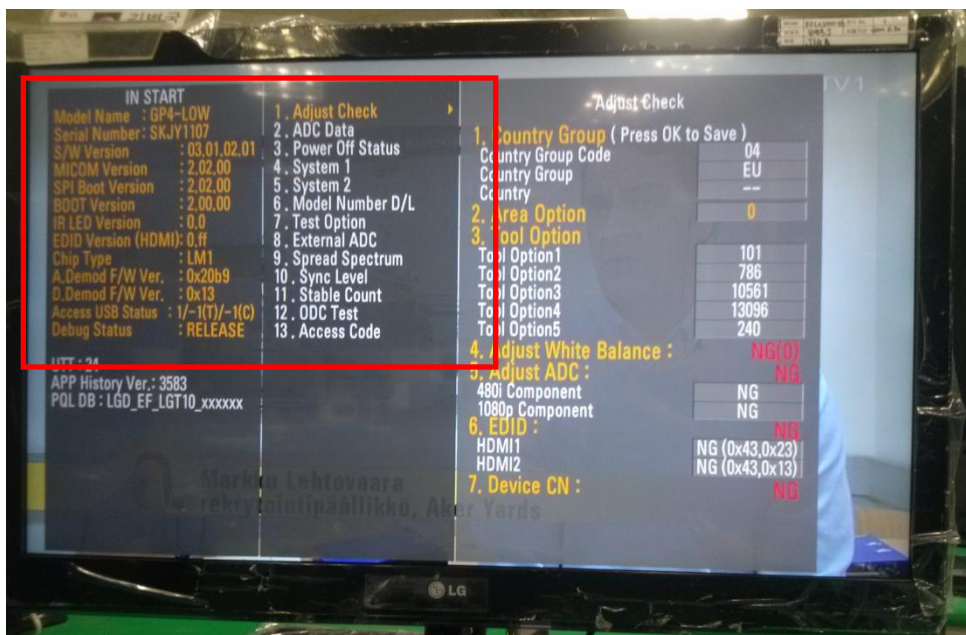

Press the IN-START with the remote controller for adjustment

Standard Repair Process Detail Technical Manual

Error symptom	A. Video error _Vertical/Horizontal bar, residual image, light spot	Established date		
Content	LCD TV connection diagram (1)	Revised date		A7



As the part connecting to the external input, check the screen condition by signal

Standard Repair Process Detail Technical Manual

Error symptom	A. Video error_Color error	Established date		
Content	Check and replace Link Cable(LVDS) and contact condition	Revised date		A8/A9

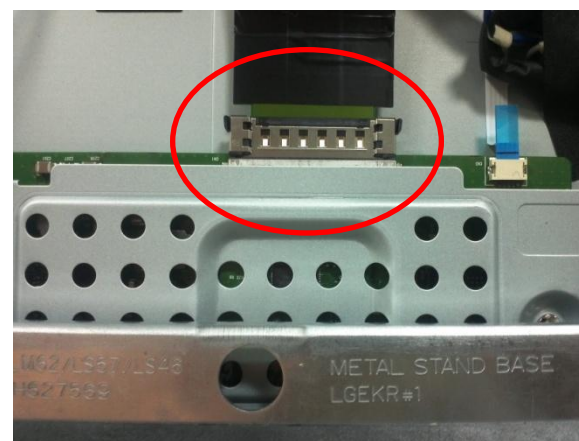

1. Check and replace LVDS Cable
2. Check LVDS connection condition

Standard Repair Process Detail Technical Manual

Error symptom	A. Video error_Color error	Established date		
Content	Adjustment Test pattern - ADJ Key	Revised date		A10

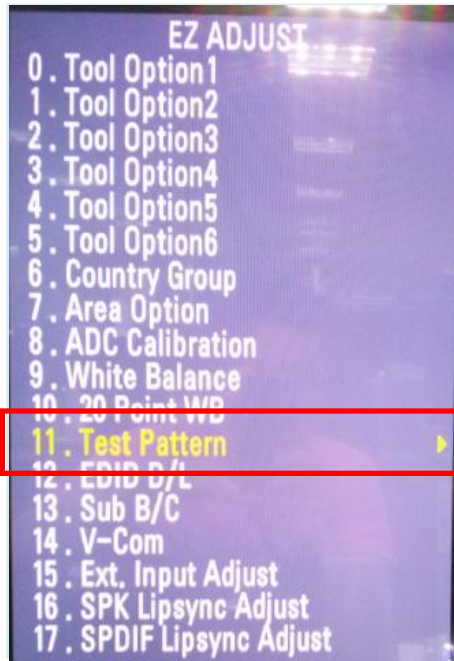

You can view 6 types of patterns using the ADJ Key

Checking item : 1. Defective pixel 2. Residual image 3. MODULE error (ADD-BAR,SCAN BAR..)
4.Video error (Classification of MODULE or Main-B/D)

Appendix : Exchange T-Con Board (1)



Solder defect, CNT Broken



Solder defect, CNT Broken



Solder defect, CNT Broken



Solder defect, CNT Broken

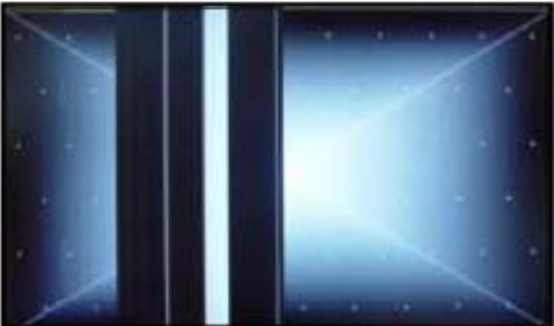

Solder defect, CNT Broken



Abnormal Power Section

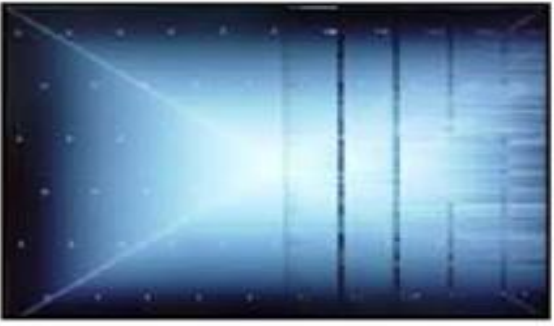

Solder defect, Short/Crack



Abnormal Power Section



Solder defect, Short/Crack

Appendix : Exchange T-Con Board (2)

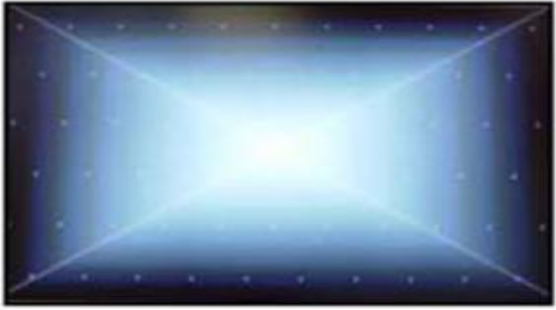

Abnormal Power Section



Abnormal Power Section



Solder defect, Short/Crack



Solder defect, Short/Crack



Fuse Open, Abnormal power section



Abnormal Display



GRADATION



Noise

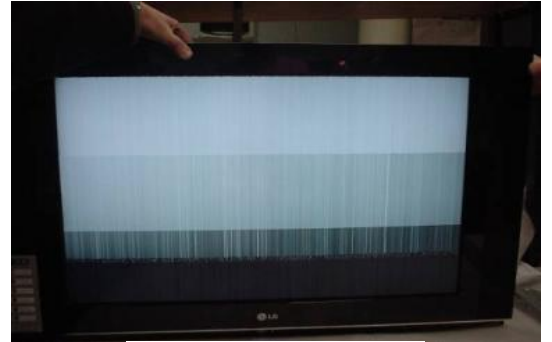

GRADATION

Appendix : Exchange the Module (1)



Panel Mura, Light leakage



Panel Mura, Light leakage



Press damage

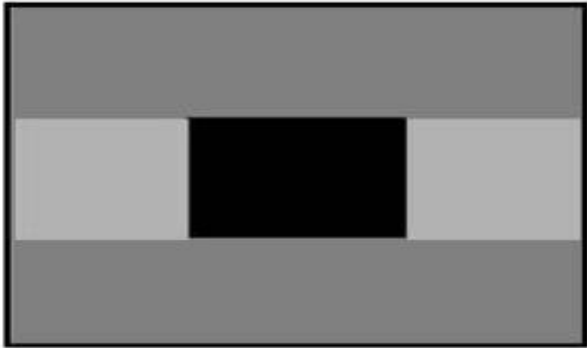

Crosstalk



Press damage



Crosstalk



Press damage

Un-repairable Cases

In this case please exchange the module.

Appendix : Exchange the Module (2)

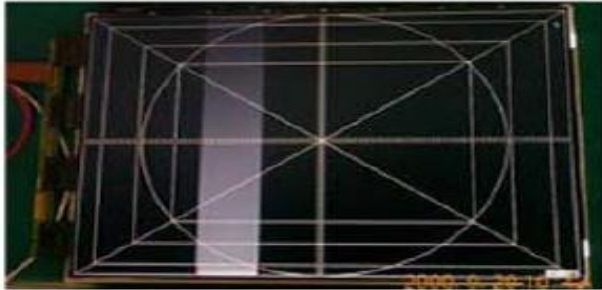

Vertical Block
Source TAB IC Defect



Vertical Line
Source TAB IC Defect



Vertical Block
Source TAB IC Defect



Horizontal Block
Gate TAB IC Defect

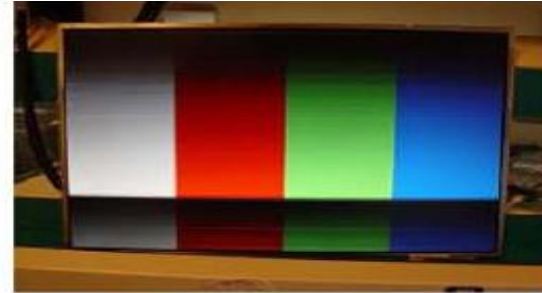

Horizontal Block
Gate TAB IC Defect

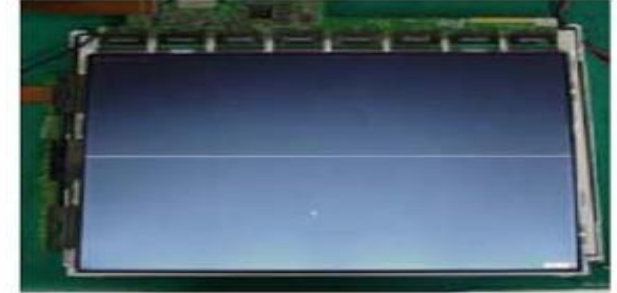

Horizontal line
Gate TAB IC Defect

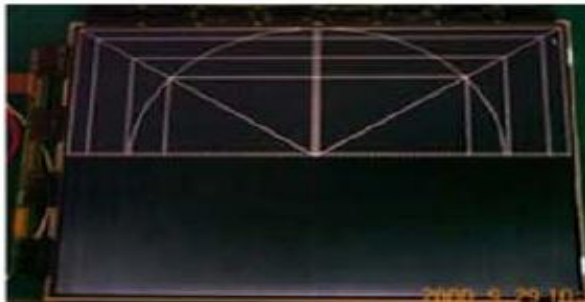

Horizontal Block
Gate TAB IC Defect

Un-repairable Cases

In this case please exchange the module.

Standard Repair Process Detail Technical Manual

Error symptom	B. Power error _No power	Established date		
Content	Check front display LED	Revised date		A11

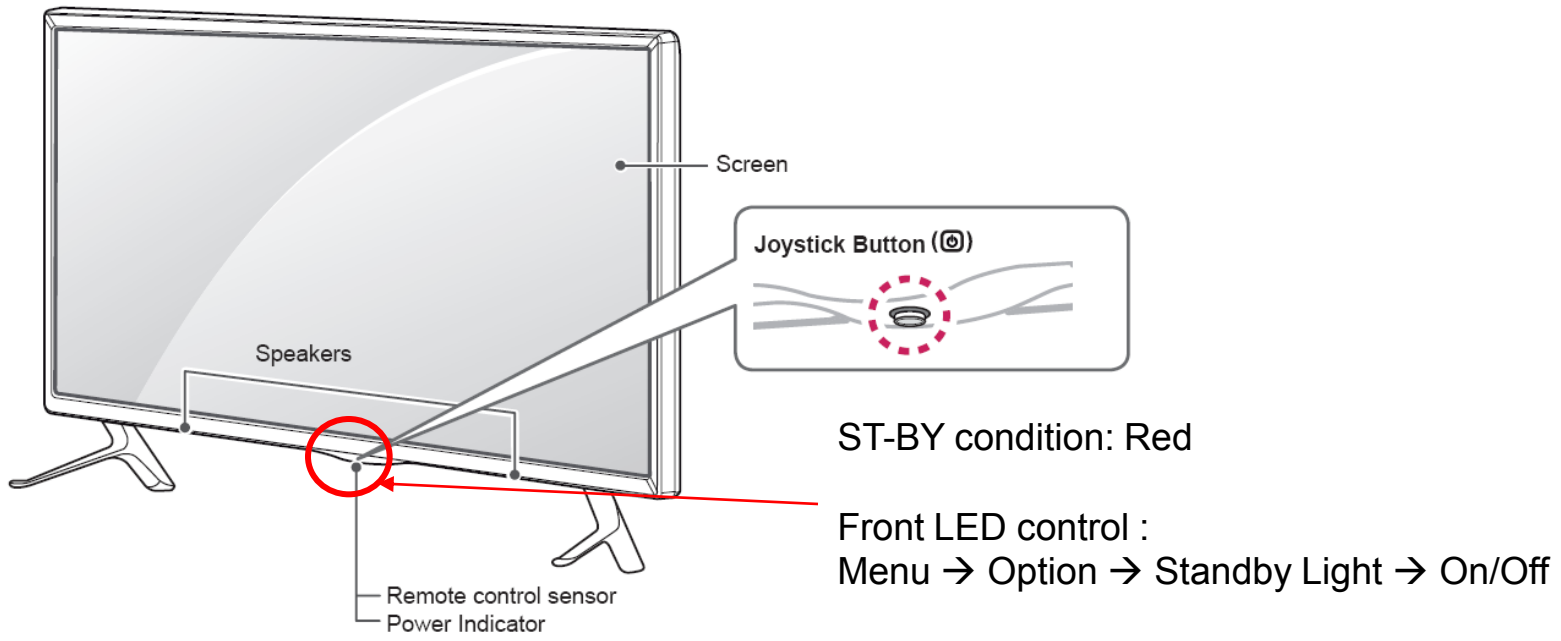

Standard Repair Process Detail Technical Manual

Error symptom	B. Power error _No power	Established date		
Content	Check power input voltage and ST-BY 3.5V	Revised date		A12

Check D.13.2V (4,5,6 PIN)

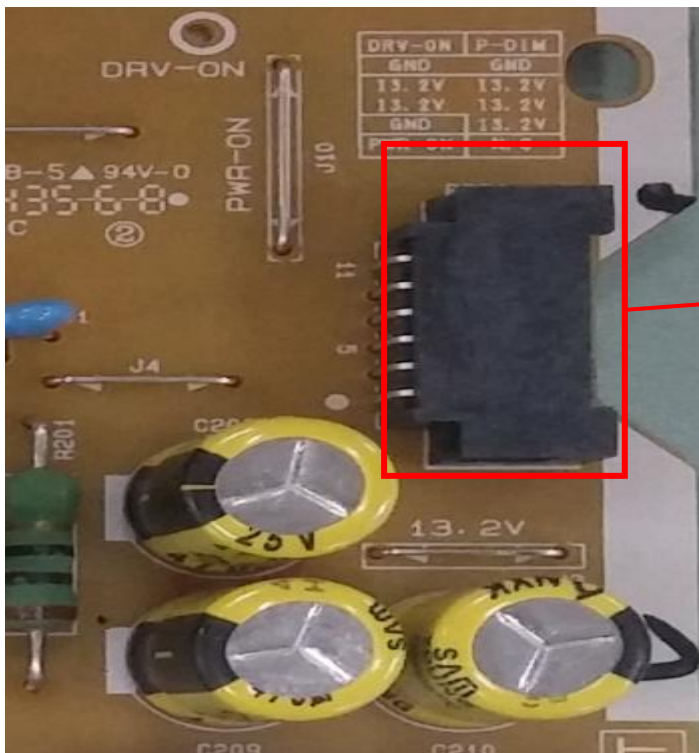

12 Pin (Power Board ↔ Main Board)			
SMH200-H12S4			
1	Power on	2	PDIM#2
3	GND	4	D.13.2V
5	D.13.2V	6	D.13.2V
7	A.13.2V	8	A.13.2V
9	GND	10	GND
11	DRV_ON	12	PDIM#1

Standard Repair Process Detail Technical Manual

Error symptom	B. Power error _No power	Established date		
Content	Checking method when power is ON	Revised date		A13

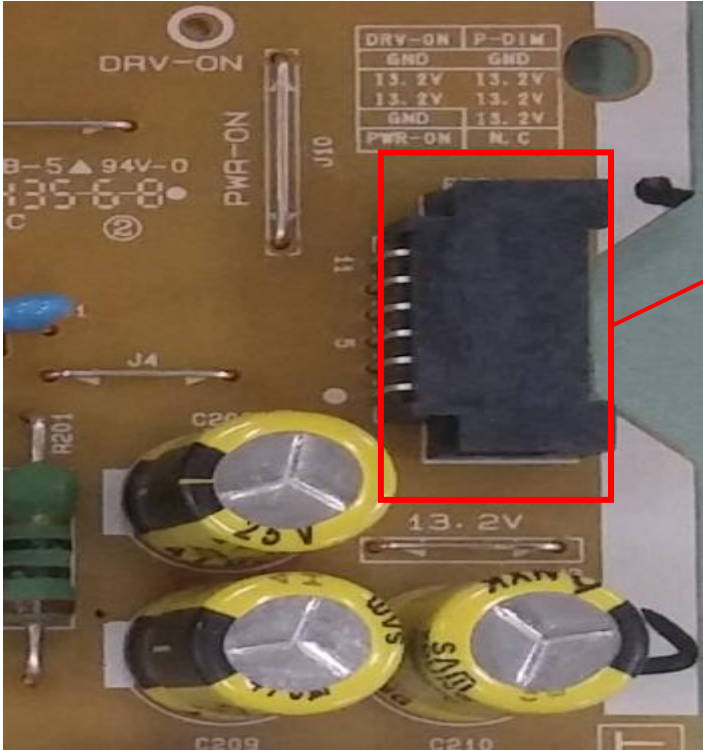

Check “power on(Pin 1)” pin is high(about 3.3V)

12 Pin (Power Board ↔ Main Board)			
SMH200-H12S4			
1	Power on	2	PDIM#2
3	GND	4	D.13.2V
5	D.13.2V	6	D.13.2V
7	A.13.2V	8	A.13.2V
9	GND	10	GND
11	DRV_ON	12	PDIM#1

Standard Repair Process Detail Technical Manual

Error symptom	B. Power error _Off when on, off whiling viewing	Established date		
Content	POWER OFF MODE checking method	Revised date		A14

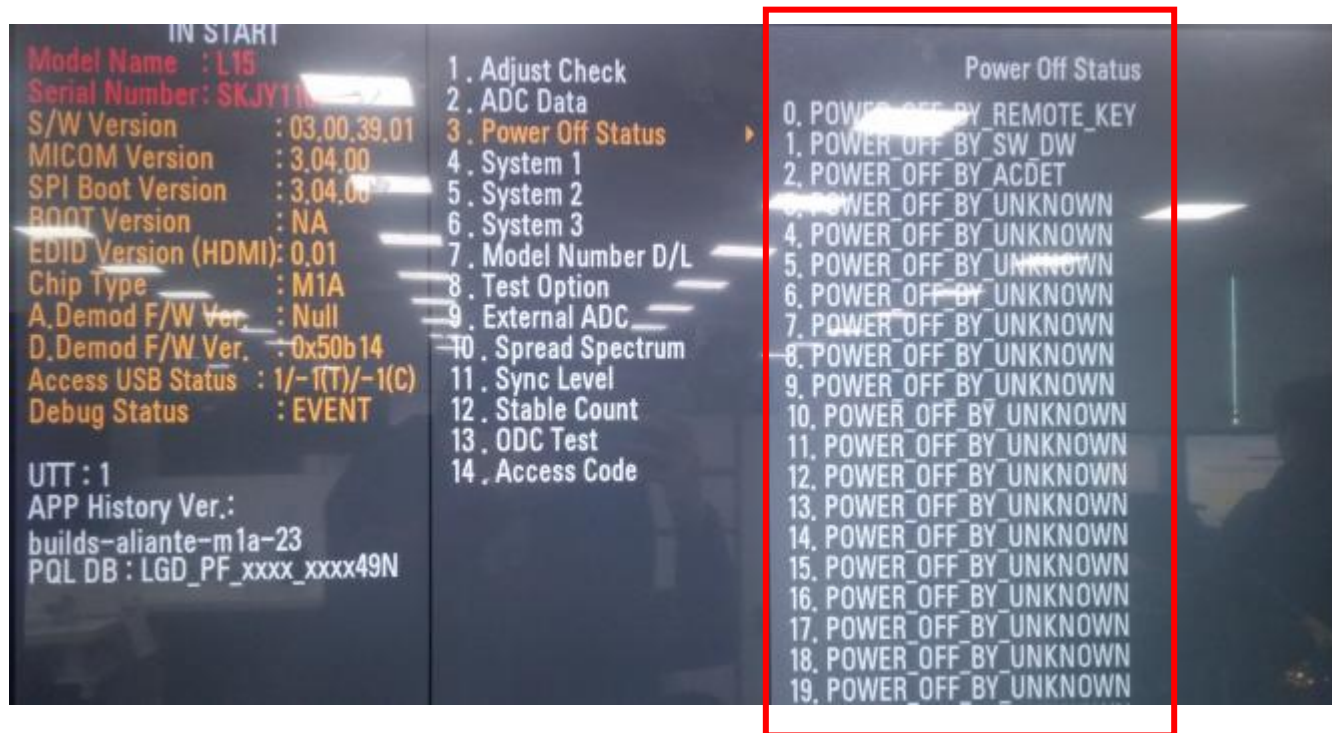

Checking order

1. Press the IN-START button of the remote controller for adjustment
2. Check the entry into adjustment item 3.

Standard Repair Process Detail Technical Manual

Error symptom	C. Audio error_No audio/Normal video	Established date		
Content	Checking method in menu when there is no audio	Revised date		A15

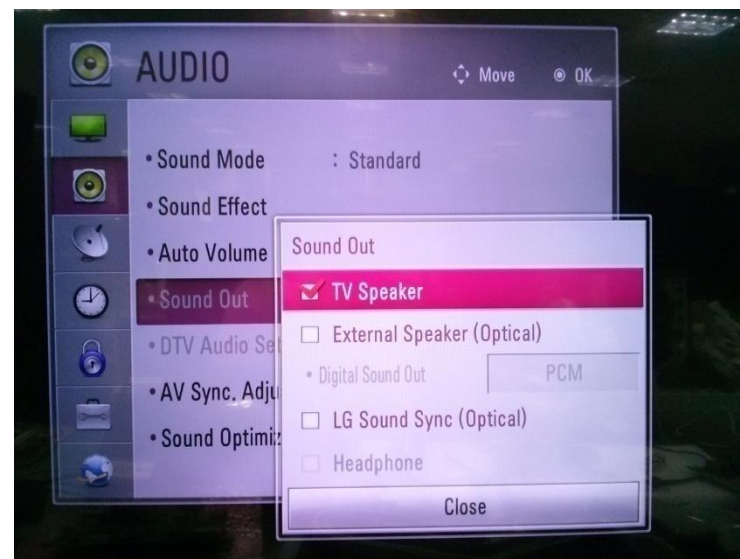
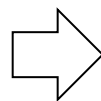

Checking order

1. Press the MENU button on the remote controller
2. Select the AUDIO function of the Menu
3. Select TV Speaker Check

Standard Repair Process Detail Technical Manual

Error symptom	C. Audio error_No audio/Normal video	Established date		
Content	Voltage and speaker checking method when there is no audio	Revised date		A16



12 Pin (Power Board ↔ Main Board)			
SMH200-H12S4			
1	Power on	2	PDIM#2
3	GND	4	D.13.2V
5	D.13.2V	6	D.13.2V
7	A.13.2V	8	A.13.2V
9	GND	10	GND
11	DRV_ON	12	PDIM#1

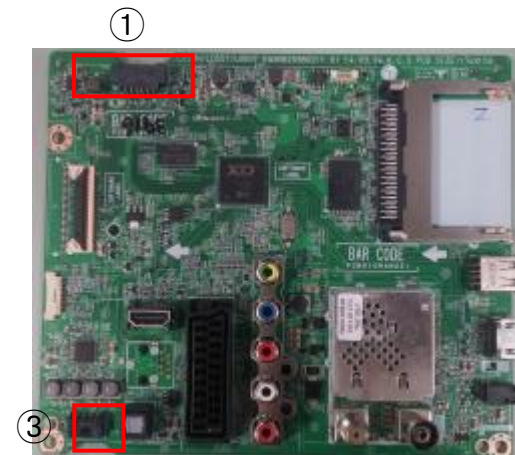

< Main Ass'y >

Checking order

1. Check the contact condition of or 13.2V connector of Main Board
2. Measure the 13.2V input voltage supplied from Power Board
(If there is no input voltage, remove and check the connector)
3. Connect the tester RX1 to the speaker terminal and if you hear the Chik Chik sound when you touch the GND and output terminal, the speaker is normal.

Standard Repair Process Detail Technical Manual

Error symptom	D. Function error_ No response in remote controller, key error	Established date		
Content	Remote controller operation checking method	Revised date		A17

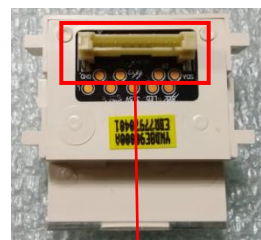

① < Sub Ass'y >

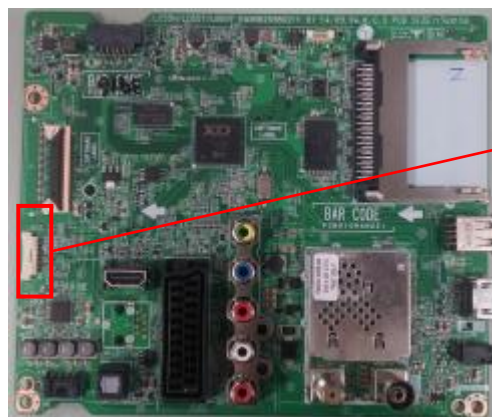

< Main Ass'y >

P4600

1	GND
2	KEY1
3	KEY2
4	3.5V_ST
5	GND
6	LED R
7	IR
8	GND
9	SCL
10	SDA

Checking order

- 1, 2. Check IR cable condition between IR & Main board.
3. Check the st-by 3.5V on the terminal 4.
4. When checking the Pre-Amp when the power is in ON condition, it is normal when the Analog Tester needle moves slowly, and defective when it does not move at all.