

Simpson panel instruments...

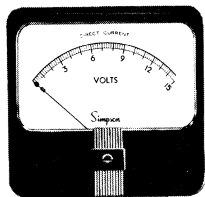

900 STOCK TYPES

... plus **HUNDREDS MORE**, custom-built
from standing tools ✕

INSTRUMENTS THAT STAY ACCURATE

* Send us your special meter requirements today. Let our top-flight engineers work out solutions or make recommendations best suited to your needs.

YOUR ELECTRONIC PARTS DISTRIBUTOR
HAS HUNDREDS IN STOCK!

Simpson ELECTRIC COMPANY

5200 West Kinzie St., Chicago 44, Ill. Phone: EStebrook 9-1121
In Canada: Bach-Simpson, Ltd., London, Ontario

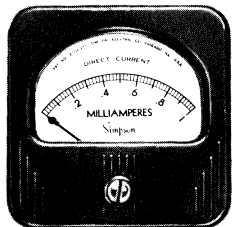

2½" RECTANGULAR
ACCURACY: ±2%
SCALE LENGTH: 1 7/8"

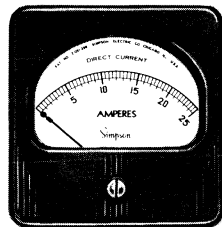

3½" RECTANGULAR
ACCURACY: ±2%
SCALE LENGTH: 2-9/16"



2½", 3½", 4½"
WIDE VUE
ACCURACY: ±3%

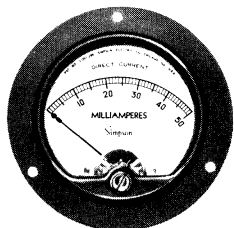

2½" or 3½" ROUND
ACCURACY: ±2%
SCALE LENGTH: 1 7/8"

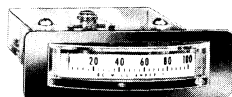

EDGEWISE
ACCURACY: DC ±2%
SCALE LENGTH: 1 7/8"

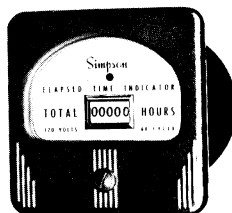

ELAPSED TIME INDICATOR
110/220 VOLTS

OPERATOR'S MANUAL

VOLT-OHM-MILLIAMMETER

MODEL 262

Courtesy of Simpson260.com
& Instrument Meter Specialties - MeterSales.com

SIMPSON ELECTRIC COMPANY

5200 W. Kinzie St., Chicago 44, Illinois, Estebrook 9-1121

In Canada, Bach-Simpson, Ltd., London, Ontario

Copyright 1958 Simpson Electric Co., Chicago 44, Illinois

Issued 4-58

Printed in USA

SECTION I

GENERAL DESCRIPTION

The Simpson Model 262 Volt-Ohm-Milliammeter is the most compact complete multimeter available. It has a sensitivity of 20,000 ohms per volt, which has become recognized as the desirable value for general service applications.

Its ranges are especially well adapted for testing and locating troubles in all types of electrical and electronic circuits. The extra-large seven inch meter dial provides a long scale which is easy to read. The unique placement of the two required controls allows the overall size of the bakelite housing to be only slightly larger than the size of the 7 inch basic meter movement. The sensitivity of the basic meter (50 microamperes) allows application of this instrument to servicing problems with very little loading effect.

ACCESSORY TEST LEADS FURNISHED

Each instrument is furnished with an operator's manual, a pair of test leads with removable alligator clips, and a 4000 volt DC probe extension. The red and black test leads have probe tips which are threaded near the base. The alligator clips may be screwed on or off either test probe; this provides either a probe tip or clip for the operator's convenience.

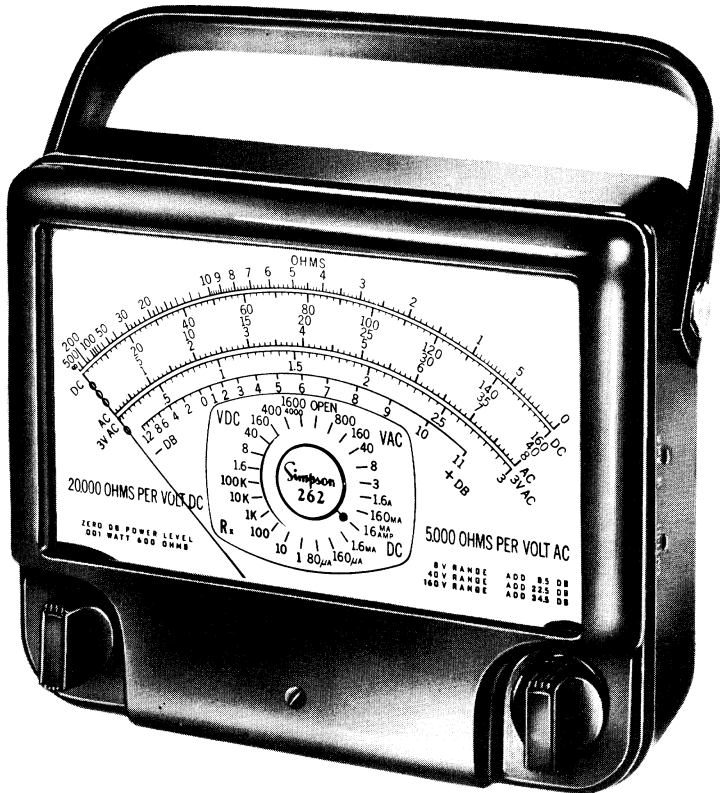

FIGURE 1. THE SIMPSON MODEL 262 VOLT-OHM-MILLIAMMETER

GENERAL DESCRIPTION

HIGH DC VOLTAGE EXTENSION

The 4000 volt DC probe extension screws on over the end of one probe tip. Screw it on the red probe tip when measuring a high positive voltage, or screw it on the black probe tip when measuring a high negative voltage. For either connection, screw an alligator clip over the end of the high voltage probe extension.

LEAD CONNECTIONS TO METER

The black test lead connects the meter circuits through the jack marked COM on the left hand side of the instrument for all applications. The red test lead connects most meter circuits through the POS jack, which is also on the left hand side of the instrument.

The only exceptions to the use of the POS jack are for OUTPUT voltage measurements, and for the 16 ampere DC current range. For each of these circuits, the red lead connects the meter circuit through jacks on the right hand side of the instrument. The jacks for these circuits are marked 16 AMP and OUTPUT.

INSTRUMENT CONSTRUCTION

The electrical circuit is designed to give maximum insurance against damage to the component parts. Very accurate carbofilm resistors are used to insure long life and dependability. Each resistor is held firmly in place on one of the molded bakelite shelves designed for this instrument.

The high sensitivity of the meter movement (50 microam-

GENERAL DESCRIPTION

peres) can only be obtained in a movement which is also sensitive to physical vibration and shock. It is very important that you exercise extreme caution to prevent your Model 262 from being damaged.

ACCURACY

Measurement accuracy is 3% DC and 5% AC of full scale deflection.

ADJUST-A-VIEW HANDLE

The comfortable plastic cover over the handle attached to the instrument case encloses a steel strap. This makes the handle rigid, so that it may be used to support the instrument at a convenient viewing angle on a bench top.

The instrument may be used in this angular position, or it may be used in a vertical or a horizontal position. The most accurate results are obtained when the instrument is in a horizontal position, because this minimizes bearing friction in the armature mounting.

MEASUREMENT RANGES

DC VOLTS

0-1.6 volts

0-8 volts

0-40 volts

0-160 volts

0-400 volts

0-1600 volts

0-4000 volts

20,000 ohms per volt sensitivity

GENERAL DESCRIPTION

AC VOLTS

0-3	volts	
0-8	volts	
0-40	volts	5,000 ohms per volt sensitivity
0-160	volts	
0-800	volts	

AUDIO FREQUENCY OUTPUT VOLTS

0-3	volts	
0-8	volts	with 0.1 microfarad series capacitor
0-40	volts	
0-160	volts	

VOLUME LEVEL IN DECIBELS

-12 to +11	DB	
+ 3.5 to +19.5	DB	Reference Level (0DB) .001 watt
+10.5 to +33.5	DB	in 600 ohms
+22.5 to +45.5	DB	

DC RESISTANCE

0-500 ohms	(4.5 ohms center)
0-5,000 ohms	(45 ohms center)
0-50,000 ohms	(450 ohms center)
0-500,000 ohms	(4,500 ohms center)
0-5 megohms	(45,000 ohms center)
0-50 megohms	(450,000 ohms center)

GENERAL DESCRIPTION

DC CURRENT

0-80	microamperes	
0-160	microamperes	
0-1.6	milliamperes	
0-16	milliamperes	267 millivolts maximum drop
0-160	milliamperes	
0-1.6	amperes	
0-16	amperes	

DC VOLTAGE MEASUREMENTS

Measure DC voltage by applying the test leads across the unknown voltage to connect it into the indicating meter through suitable internal series resistors. The meter movement has a full scale sensitivity of 50 microamperes and a resistance of 5200 ohms. The series resistors increase the total instrument resistance to 20,000 ohms per volt for all DC voltage ranges.

AC VOLTAGE MEASUREMENTS

AC voltage measurements, including output and decibel readings, are made by rectifying the AC voltage with an internal copper oxide rectifier. The resulting DC voltage is applied to the meter circuit.

An internal shunt resistor, individually calibrated for the characteristics of each instrument, is connected in parallel with the meter movement. The overall sensitivity of the instrument is 5,000 ohms per volt for all AC ranges.

GENERAL DESCRIPTION

DC RESISTANCE MEASUREMENTS

Two internal batteries furnish power for measuring resistances with the Simpson Model 262. A low voltage battery (1.5 volts) furnishes power for the lowest four ranges, and a high voltage battery (22.5 volts) furnishes the power for the highest two ranges. The internal circuits contain precision series and shunt resistors to produce accurate indications of resistance values.

DC CURRENT MEASUREMENTS

A ring shunt, made of specially calibrated resistors, divides the total current so that the proportional amount through the meter movement is an accurate indication of the total current. This is true through all the DC current ranges.

POWER REQUIREMENTS

No power connections are required for any application of the Simpson Model 262 Volt-Ohm-Milliammeter. This is a completely self-contained instrument. The insignificant amount of power which is required for each voltage and current measurement comes directly from the circuit into which the instrument is connected.

For resistance measurements, power is furnished from one of the two batteries installed in the instrument.

SECTION II

OPERATING INSTRUCTIONS

CAUTION

When you measure voltage or current, as a protection to yourself, form the habit of turning off all power to the circuit under test. Connect the test leads at the desired points in the circuit, and then turn on the power while you read the meter. Turn off the power before disconnecting the test leads.

ZERO THE POINTER

Before making any measurements, check to see that the pointer indicates zero when the meter is in its operating position. If the pointer is off zero, adjust the screw located in the bakelite case below the center of the meter as shown in figure 1. Use a small screwdriver to turn this screw slowly clockwise or counterclockwise until the pointer is exactly over the zero mark on the scale.

DC VOLTAGE MEASUREMENTS, 0-1600 VOLTS

1. Rotate the range selector switch in the lower right hand corner to set the range pointer for the desired range in the VDC area of markings. These DC voltage ranges are marked with black numerals. **WHEN IN DOUBT AS TO THE VOLTAGE PRESENT, ALWAYS USE THE HIGHEST RANGE FIRST AS A PROTECTION TO THE INSTRUMENT.** After you observe the first reading and

OPERATING INSTRUCTIONS

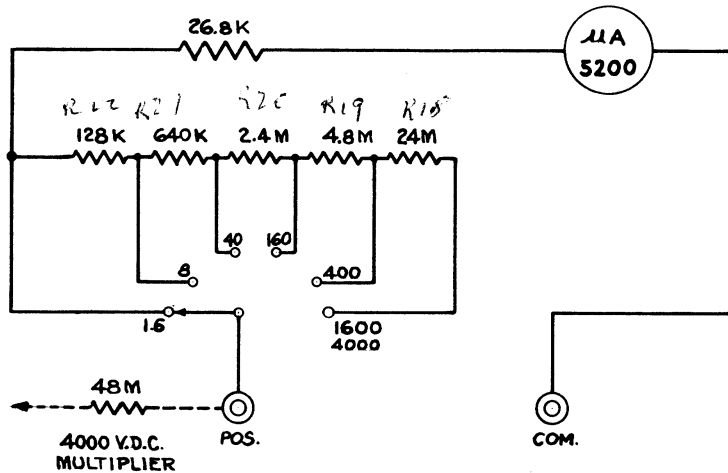

FIGURE 2. SIMPLIFIED DC VOLTMETER CIRCUIT

determine that a lower range may be used, set the range selector for the lower range to obtain more deflection and a more accurate reading.

2. Plug the black test lead in the COM jack, and the red test lead in the POS jack. These jacks are both on the left hand side of the instrument.
3. Screw on the alligator clips over the probe tips if desired. Connect the black probe to the negative side of the circuit to be measured. Connect the red probe to the positive side of the circuit.
4. Turn on the power in the circuit to be tested. If the pointer deflects to the left of zero, the lead connections are reversed. Turn off the power and reverse the connections of the test probes. Then turn on the power again.

OPERATING INSTRUCTIONS

5. Read the voltage on the black arc marked DC, which is second from the top of the dial.

For the 1.6 volt range, use the 0–160 figures and divide by 100.

For the 8, 40, and 160 volt ranges, read the figures directly.

For the 400 volt range, use the 0–40 figures and multiply by 10.

For the 1600 volt range, use the 0–160 figures and multiply by 10.

6. Turn off the power before disconnecting the meter leads.

DC VOLTAGE MEASUREMENTS FROM 1600 TO 4000 VOLTS

CAUTION

Use extreme care when you check high voltage. Always turn off the power before making meter connections, and do not touch the meter or the test leads while you make the measurements. Turn off the power before disconnecting the leads.

1. Rotate the range selector switch in the lower right hand corner to set the range pointer at 1600–4000 VDC.
2. Plug the black test lead into the COM jack and the red test lead into the POS jack on the left hand side of the instrument.
3. Screw the high voltage probe extension, which is furnished with the Model 262, over one of the test probes.

OPERATING INSTRUCTIONS

Screw it on the red test probes for measurements of high positive voltages, or over the black test probe for high negative voltages. Screw the alligator clips over the ends of the test probe and the high voltage extension.

4. Be sure the power is turned off in the circuit to be measured and that all its capacitors have been discharged. Connect the black test probe to the negative side of the circuit to be measured, and the red test probe to the positive side of the circuit.
5. Turn the power on. Do not touch the meter or the leads. If the meter pointer deflects to the left, the lead connections are reversed. Turn off the power, discharge all capacitors, reverse the lead connections, and then turn the power on again.
6. Read the voltage. Use the 0-40 figures for the black DC arc, which is second from the top of the dial. Multiply the reading by 100.
7. Turn off the power and discharge all capacitors before disconnecting the meter leads.

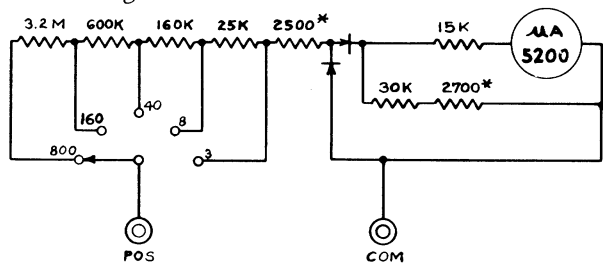

* APPROXIMATE VALUE,
CALIBRATED FOR EACH
INDIVIDUAL UNIT.

FIGURE 3. SIMPLIFIED AC VOLTMETER CIRCUIT

OPERATING INSTRUCTIONS

AC VOLTAGE MEASUREMENTS

All AC voltages measured with the Simpson Model 262 Volt-Ohm-Milliammeter are assumed to have a waveform which is a pure sine wave. For any other waveform of input voltage, readings will be relative only.

All AC voltages are indicated in terms of their R.M.S. values.

1. Rotate the range selector switch in the lower right hand corner until the range pointer shows an appropriate VAC range. The VAC ranges are marked in red. WHEN IN DOUBT AS TO THE VOLTAGE PRESENT, ALWAYS USE THE HIGHEST RANGE FIRST AS A PROTECTION TO THE INSTRUMENT. After you observe the first reading and determine that a lower range may be used, set the range selector for the lower range to obtain more deflection and a more accurate reading.
2. Plug the black test lead in the COM jack, and the red test lead in the POS jack. These jacks are both on the left hand side of the instrument.
3. Screw on the alligator clips over the probe tips if desired. Connect the black and red test probes across the voltage source which is to be measured. AC voltages will read correctly regardless of the polarity of the test lead connections.
4. Turn on the power to the circuit which is to be measured.
5. For the 3 volt AC range only, read the voltage on the

OPERATING INSTRUCTIONS

red arc marked 3 VAC which is second from the bottom of the dial. Use the red figures below the arc.

For the other ranges, use the red arc marked AC, which is third from the bottom of the dial. Read the black digits between the AC and DC arcs. For the 8, 40, and 160 volt ranges, use the figures as they are marked. For the 800 volt range, read the 0-8 figures and multiply by 100.

6. Turn off the power before disconnecting the meter leads.

AUDIO FREQUENCY OUTPUT MEASUREMENTS

This circuit in the Simpson Model 262 Volt-Ohm-Milliammeter measures only the AC portion of voltage when there is a mixture of AC and DC voltage. An example of this would be the voltages at the plate of an audio amplifier tube.

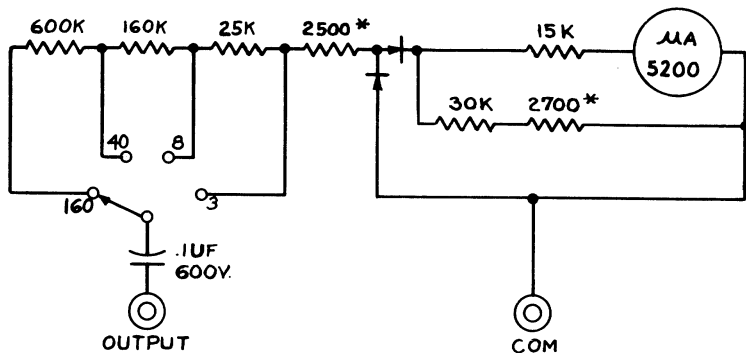

* APPROXIMATE VALUE,
CALIBRATED FOR EACH
INDIVIDUAL UNIT.

FIGURE 4. SIMPLIFIED OUTPUT METER CIRCUIT

OPERATING INSTRUCTIONS

1. Rotate the range selector switch in the lower right hand corner to any of the four VAC ranges used for Output measurements. These ranges are 3, 8, 40, and 160 volts. WHEN IN DOUBT AS TO THE VOLTAGE PRESENT, ALWAYS USE THE HIGHEST RANGE FIRST AS A PROTECTION TO THE INSTRUMENT. After you observe the first reading and determine that a lower range may be used, set the range selector switch for the lower range to obtain more deflection.
2. Plug the black test lead into the jack marked COM, on the left hand side of the instrument. Plug the red test lead into the jack marked OUTPUT, on the right hand side of the instrument. Screw the alligator clips over the ends of the test probes if desired.
3. Connect the test probes across the voltage source which is to be measured. Output voltages will indicate correctly regardless of the polarity of lead connections, but it is common practice to connect the black test lead to the side of the circuit which is closer to ground potential.
4. Turn on the power in the circuit which is to be measured.
5. For the 3 volt range only, read the red arc marked 3 VAC, which is second from the bottom of the dial. Read the red figures below the arc.

For the other ranges, read the red arc marked AC, which is third from the bottom of the dial, and use the black figures between the AC and DC arcs.

6. Turn off the power before disconnecting the test leads.

OPERATING INSTRUCTIONS

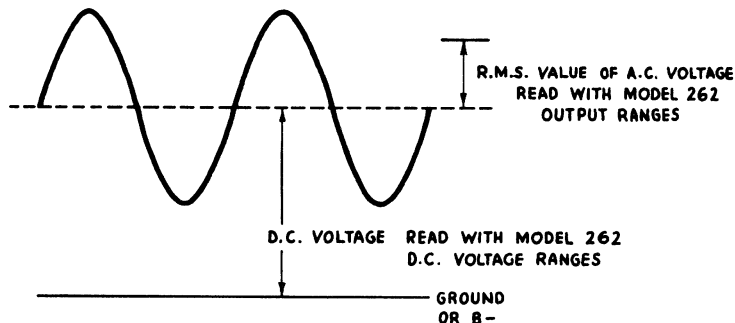

FIGURE 5. MEASURING DC AND AC COMPONENTS OF MIXED VOLTAGES

VOLUME LEVEL MEASUREMENTS IN DECIBELS (DB)

The scale is based on a zero DB power level of .001 watt in 600 ohms impedance. Correct any reading for a zero power level of .006 watt in 500 ohms by subtracting 7 DB.

1. Rotate the range selector switch to any of the four VAC ranges required. WHEN IN DOUBT AS TO THE SIGNAL STRENGTH PRESENT, ALWAYS USE THE HIGHEST RANGE FIRST AS A PROTECTION TO THE INSTRUMENT. After obtaining the first reading, the switch can be reset to a lower range if the signal is within the lower range.
2. Plug the black test lead into the jack marked COM, and the red test lead into the jack marked POS. If there is any DC voltage present along with the AC signal which is to be measured, plug the red test lead into the OUTPUT jack rather than into the POS jack. Screw the alligator clips over the ends of the test probes if desired.

OPERATING INSTRUCTIONS

3. Connect the test probes across the source of signal which is to be measured. Correct readings will result from either polarity of lead connections.
4. Turn on the power in the circuit to be measured.
5. Read decibels on the inner arc marked DB. The markings on the DB arc correspond to the 3 VAC scale and range. For each of the other three ranges, add the fixed quantity shown in the lower right hand corner of the dial to the reading on the DB arc.

For example, if the reading on the DB arc is +8, and the meter range is set at 40 VAC, the decibel value is 30.5 (8 plus 22.5). All DB measurements are read with an assumption that the indicated power is dissipated across the reference impedance load of 600 ohms.

6. Turn off the power before disconnecting the meter leads.

DC RESISTANCE MEASUREMENTS

CAUTION

Before you make any resistance measurements in an electrical or electronic circuit, be sure the power is turned off and all the capacitors are discharged, so that no voltage remains. Otherwise you may damage your meter circuits.

1. Rotate the range selector switch in the lower right hand corner until the range pointer indicates any of the six resistance ranges desired. These ranges are marked with the red figures in the area designated Rx. The range

OPERATING INSTRUCTIONS

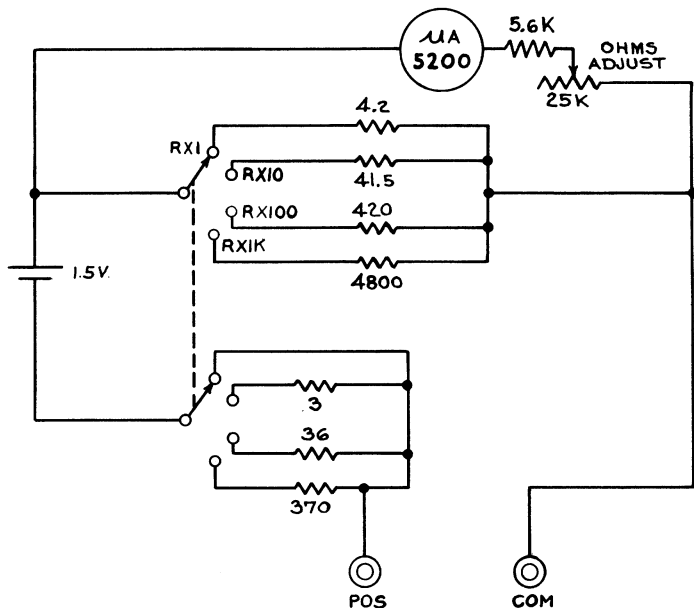

FIGURE 6. MODEL 262 OHMMETER CIRCUITS FOR THE 4 LOWEST RANGES

markings indicate that a resistance reading is to be multiplied by the quantity shown at the range pointer position.

2. Plug the black test lead into the COM jack, and the red test lead into the POS jack. These jacks are both on the left hand side of the instrument. Screw the alligator clips over the ends of the test probes if desired.
3. Short the test probes together. While the probes are shorted, rotate the zero ohms knob, in the lower left hand corner of the front panel, to set the meter pointer for full scale deflection. This is a zero ohms indication.

OPERATING INSTRUCTIONS

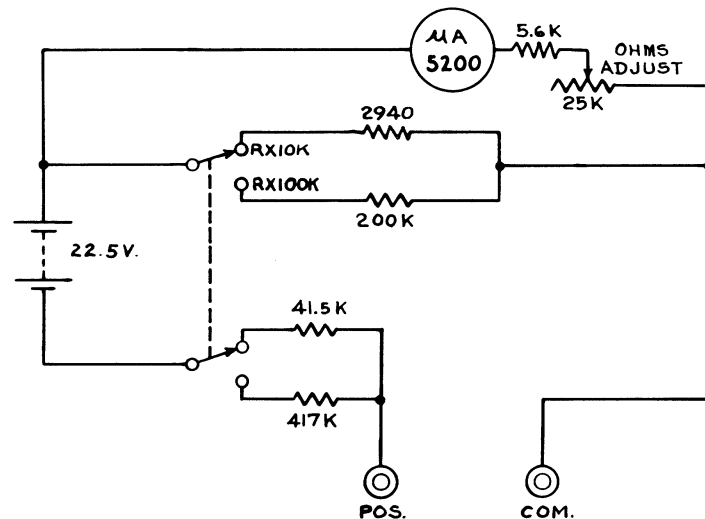

FIGURE 7. MODEL 262 OHMMETER CIRCUITS FOR THE 2 HIGHEST RANGES

4. Separate the test probes and connect them across the resistance or the portion of the circuit which is to be measured. The most accurate indication is obtained on the range which produces the reading closest to the center of the scale.
5. Read the value indicated on the arc marked OHMS. This is printed in red at the top of the dial. Note that the scale increases from right to left.

For the Rx1 range, read the resistance in ohms directly on the red arc.

For the Rx10 range, multiply the reading by 10 (add one zero) for ohms.

For the Rx100 range, multiply the reading by 100 (add

OPERATING INSTRUCTIONS

two zeros) for ohms.

For the Rx1K range, multiply the reading by 1000 (add three zeros) for ohms, or read the scale directly for Kilohms.

For the Rx10K range, multiply the reading by 10,000 (add four zeros) for ohms, or multiply by ten (add one zero) for Kilohms.

For the Rx100K range, multiply the reading by 100,000 (add five zeros) for ohms, multiply by 100 (add two zeros) for Kilohms, or divide by ten for Megohms.

Example: A resistance is measured on the Rx100K range, and the pointer indicates 15 on the OHMS scale. The value of resistance is $15 \times 100,000$, which is 1,500,000 ohms. The same resistance can be measured as 15×100 , or 1500 Kilohms; or it can be measured as $15 \div 10$, or 1.5 Megohms.

CAUTION

Do not leave the range selector switch in any ohmmeter position when the instrument is not in use. The test leads can be shorted accidentally, and this will cause unnecessary current drain through the batteries. The batteries will wear out in a shorter than normal time, and need to be replaced. It is also possible to damage the instrument by connecting external power into the ohmmeter circuit.

DC CURRENT MEASUREMENTS, 0-1.6 AMPERES

CAUTION

Never connect the test leads across any source vol-

OPERATING INSTRUCTIONS

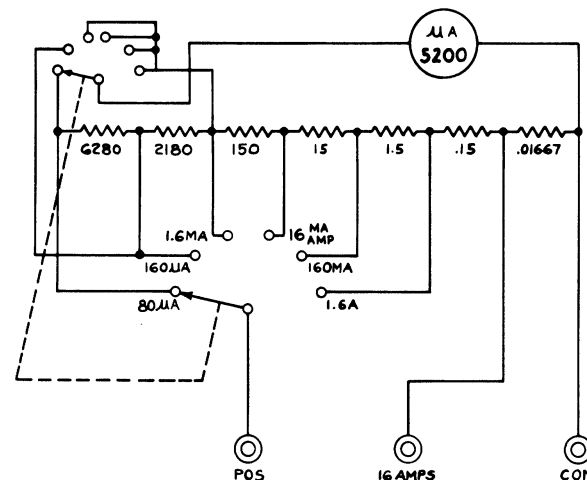

FIGURE 8. MODEL 262 CIRCUIT FOR DC CURRENT MEASUREMENTS

tage directly when the Model 262 is used as a current meter. This will damage the instrument. Always connect the meter in series with the load across the source of voltage.

1. Rotate the range selector switch in the lower right hand corner of the instrument to set the range pointer at any of the DC current ranges desired. The DC current ranges are marked in black in the area identified as DC. WHEN IN DOUBT AS TO THE VALUE OF CURRENT, ALWAYS USE THE HIGHEST RANGE FIRST AS A PROTECTION TO THE INSTRUMENT. After you have made the first reading, you can reset the range switch for a lower range and more deflection if the current value is within the lower range.
2. Plug the black test lead into the COM jack, and the red

OPERATING INSTRUCTIONS

test lead into the POS jack. These jacks are both on the left hand side of the instrument. Screw the alligator clips over the ends of the test probes.

3. Open the circuit in which the current is to be measured. Connect the meter in series with the circuit. Connect the red test probe toward the positive side and the black test lead toward the negative side of the opened circuit.
4. Turn on the power in the circuit which is to be measured.
5. Read the current value on the black arc marked DC, which is the second from the top of the dial. If the pointer deflects to the left, the test lead connections are reversed. Turn off the power, reverse the probes, and then turn on the power again.

On the 80 μ A range, read the figures 0–8 and multiply by 10 for microamperes.

On the 160 μ A range, read the figures 0–160 directly for microamperes.

On the 0–1.6 MA range, read the figures 0–160; divide by 100 for milliamperes or multiply by 10 for microamperes.

On the 16 MA range, read the figures 0–160 and divide by 10 for milliamperes.

On the 160 MA range, read the figures 0–160 directly for milliamperes.

On the 1.6 A range, read the figures 0–160; divide by 100 for amperes or multiply by 10 for milliamperes.

OPERATING INSTRUCTIONS

6. Turn off the power in the circuit before disconnecting the test leads. Restore the original circuit continuity.

DC CURRENT MEASUREMENTS, 0–16 AMPERES

CAUTION

Never connect the test leads across any source voltage directly when the Model 262 is used as a current meter. This will damage the instrument. Always connect the meter in series with the load across the source of voltage.

1. Rotate the range selector switch in the lower right hand corner to place the range pointer at 16 MA-AMP.
2. Plug the black test lead into the COM jack on the left hand side of the instrument, and the red test lead into the 16 AMPS jack on the right hand side. Screw the alligator clips over the ends of the test probes.
3. Open the circuit in which current is to be measured. Connect the meter in series with the circuit. Connect the red test probe toward the positive side and the black test probe toward the negative side of the opened circuit.
4. Turn on the power in the circuit which is to be measured.
5. Read the current value on the black arc marked DC, which is the second from the top of the dial. Read the figures 0-160 and divide by 10 for amperes. If the pointer

OPERATING INSTRUCTIONS

deflects to the left, the test leads are connected in reverse. Turn off the power, reverse the test probe connections, and then turn on the power again to make the reading.

6. Turn off the power before disconnecting the test leads. Restore the original circuit continuity.

SECTION III

MAINTENANCE

HANDLE WITH CARE

Always handle your Model 262 Volt-Ohm-Milliammeter with care. Protect it from shock and rough treatment. The instrument has a delicate movement which will be damaged if you are rough and careless.

If you are careful, your Model 262 will furnish many years of trouble-free service with all the advantages of its 50 microampere movement sensitivity.

SPECIAL RANGE SWITCH SETTING WHILE NOT IN USE

When the instrument is not in use, rotate the range selector switch in the right hand corner to set the range pointer at an AC range position. This places a shunt across the meter movement to damp the pointer movement. It reduces the amount and speed of pointer swing and armature inertia-response when you carry the instrument from one place to another.

MAINTENANCE

PARTS AND REPLACEMENT

All the resistors and other component parts of the Model 262 have been engineered to withstand more than the power which they should normally have to dissipate. But there are conditions under which parts may become damaged or defective and need to be replaced. Consult the circuit diagram, figure 11, to help identify any suspected part. A rear view of the instrument, which shows the system of parts layout, appears in figure 9.

Open the instrument case by removing the four screws through the back of the case and pulling off the entire case back. All the components are attached to the front panel. Be sure that the test leads are removed from their jacks on the instrument sides while you remove the back.

If the meter movement is defective, do not attempt to repair it. Any repair of this delicate movement must be performed by trained repairmen with the proper tools. Return your Model 262 to the nearest official Simpson Repair Station, or return it to the repair department at the Simpson factory.

BATTERY REPLACEMENT

Two batteries inside the case of the Model 262 are used for the ohmmeter circuits. They will wear out gradually over a long period of use. During their usable life, the OHMS ADJUST control, at the lower left hand corner of the front panel, will compensate for their aging characteristics.

When the pointer can no longer be brought to full scale (for

MAINTENANCE

zero ohms) with the OHMS ADJUST control, one or both batteries must be replaced. If this occurs in the lowest four ranges (R x 1 through R x 1K), replace the 1.5 volt #2 battery. If it occurs in the highest two ranges (R x 10K or R x 100K), replace the 22.5 volt battery. The correct replacement for the 22.5 volt battery is a Burgess U15E, an Eveready 412, or a Ray-O-Vac #516.

Remove the screws through the back of the case, and slip off the case back. Both batteries are located at the top of the instrument as shown in figure 9.

The 1.5 volt battery slides straight out of its mounting. Replace it with a fresh size D, or #2, cell. Be sure to maintain the proper polarity when you install the new battery.

To remove the 22.5 volt battery, press on the positive end of its case and pull out on the negative end of the case. Insert the negative end of the fresh battery first, and press its negative terminal against the spring contact. Then press the positive end of the battery in place and seat it in its mounting. Be sure to maintain proper battery polarity when you install the new battery.

PARTS LIST

Symbol	Description	Simpson Part No.
C1	Capacitor, 0.1 uf, 600 v	1-111679
R1	Resistor, 12K, 1/2 w, 10%	1-115655

PARTS LIST

Symbol	Description	Simpson Part No.
R2	Potentiometer, 25K	1-115053
R3	Resistor, 26.8K, 1/2 w, 1%	1-115043
R4	Resistor, 200K, 1/2 w, 1%	1-113365
R5	Resistor, 2940 ohms, 1/2 w, 1%	1-115049
R6	Resistor, 4800 ohms, 1/2 w, 1%	1-115048
R7	Resistor, 420 ohms, 1/2 w, 1%	1-115047
R8	Resistor, 41.5 ohms, Bobbin	10-805006
R9	Resistor, 4.2 ohms, Bobbin	0-008306
R10	Resistor, 15K, 1/2 w, 1%	1-113347
R11	Resistor, 3.2 megohms, 1/2 w, 1%	1-114839
R12	Resistor, 600K, 1/2 w, 1%	1-114097
R13	Resistor, 160K, 1/2 w, 1%	1-114834
R14	Resistor, 25K, 1/2 w, 1%	1-113426
R15	p/o Rectifier Assembly.	Not furnished separately.
R16	p/o Rectifier Assembly.	Not furnished separately.
R17	p/o Rectifier Assembly.	Not furnished separately.
R18	Resistor, 24 megohms, 1 w, 1%	1-114841
R19	Resistor, 4.8 megohms, 1 w, 1%	1-115040
R20	Resistor, 2.4 megohms, 1 w, 1%	1-115041
R21	Resistor, 640K, 1/2 w, 1%	1-114837
R22	Resistor, 128K, 1/2 w, 1%	1-114095
R23	Resistor, 417K, 1/2 w, 1%	1-115052
R24	Resistor, 41.5K, 1/2 w, 1%	1-115051
R25	Resistor, 370 ohms, 1/2 w, 1%	1-115050
R26	Resistor, 36 ohms, Bobbin	0-008314
R27	Resistor, 3 ohms, Bobbin	0-008240
R28	Resistor, 0.15 ohm, Bobbin	10-805000
R29	Resistor, 1.5 ohms, Bobbin	0-008258

PARTS LIST

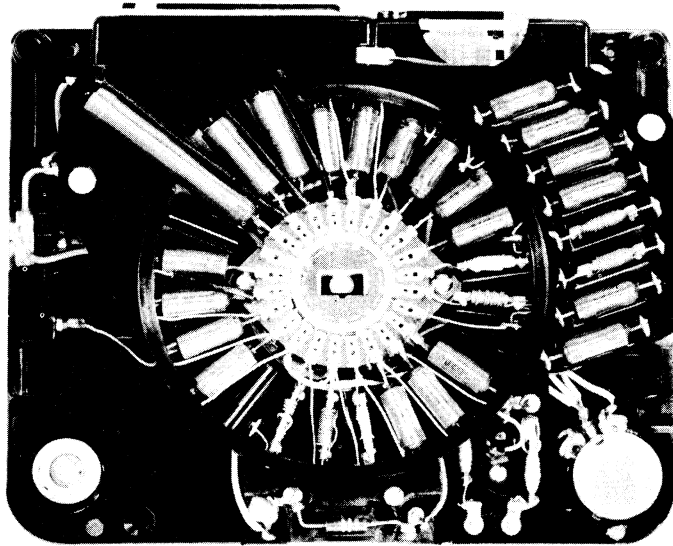

FIGURE 9. MODEL 262, REAR VIEW OF RESISTOR DECK

R30	Resistor, 15 ohms, Bobbin	0-008131
R31	Resistor, 150 ohms, $\frac{1}{2}$ w, 1%	1-115044
R32	Resistor, 2180 ohms, $\frac{1}{2}$ w, 1%	1-115045
R33	Resistor, 6280 ohms	1-115046
R34	Shunt assembly, 16 amp, 267 mv	0-008048
R35	Resistor, 48 megohms, 2% matched pair	1-115038
R36	p/o Rectifier Assembly. Not furnished separately	
	Rectifier assembly, Calibrated	0-008593
	High voltage multiplier assembly	10-890165
	Red test lead assembly	0-008460
	Black test lead assembly	0-008461
	Alligator clip assembly	10-890122
	Handle assembly	3-310812
	Case assembly with handle	10-890154

SECTION IV

SPECIAL APPLICATIONS

GENERAL

The high sensitivity of the Model 262 Volt-Ohm-Milliammeter makes it suitable to many special servicing needs. The selection of voltage ranges makes it especially well qualified for the requirements of test equipment.

For instance, the output voltage from 1.5 volt and 6 volt battery sources produce large deflections on the meter when its range is set for 1.6 volts and 8 volts. The large 7 inch scale spreads the increments of voltage across such a wide physical area that the user is able to determine better the exact value of voltage and to better judge the operation of the battery.

The large number of available ranges (33 of them) makes it easier to find a range for current, voltage, or resistance which will come closer to fitting the needs of each circuit application, and thus allow better evaluation for the user. The sensitivity of 20,000 ohms per volt D.C. has become a standard for measurements in many fields, and the loading effect imposed by such a sensitivity is considered correct for many reference measurements.

The owner of the Simpson Model 262 has this standard value with which to work. Here are some of the special applications which make this instrument especially valuable as a measuring instrument.

SPECIAL APPLICATIONS

GRID CURRENT MEASUREMENTS

The 80 microampere range of the Simpson Model 262 is so sensitive that it is possible to evaluate the grid currents of many amplifier tubes. Each scale division represents 1 microampere, and these are marked on intervals spaced widely enough apart that fractions of microamperes are easy to identify.

Since grid currents, due to leakage and grid emission, are indications of the location of troubles and also of the presence of oscillation, these current measurements are valuable in locating circuit faults which have not been determined by direct means before this time. They were always found by the process of elimination where there was no satisfactory means of measuring the currents which would indicate the nature of such faults.

F.M. AND T.V. ROUGH INTERMEDIATE FREQUENCY AMPLIFIER ALIGNMENT

When the waveform analysis in a stagger tuned i-f system shows that the circuits are badly mistuned, the procedure for alignment calls for sending through one frequency at a time and adjusting the particular slug which controls reception or rejection of that frequency. Then after each has been adjusted for maximum response for the frequency which it affects, a final adjustment is made with waveform. During the rough adjustments, a voltmeter is connected across the detector load to indicate when the maximum and minimum results are tuned for each frequency.

SPECIAL APPLICATIONS

Much better and more accurate results are obtained when the Model 262 is connected as a microammeter or milliammeter in series with the load resistor. Unsolder the detector load resistor to open the circuit, and connect the Model 262 in series with the opened circuit. Set the Range Selector Switch for an appropriate current range and adjust the frequency response with this much more sensitive circuit. The range can be reset quickly as adjustments are made.

Even a badly misaligned slug will allow some signal to get through, and the low current ranges will provide a more definite starting indication so that an increase or decrease of response is immediately recognized. Much better minimum response indications are available for trap adjustments.

If the Model 262 is used as a voltmeter for these adjustments, the high impedance of each D.C. voltage range, and its wide arc contribute to more accurate results and indications than are available with other portable multimeters.

AGC VOLTAGE MEASUREMENTS

Automatic Gain Control circuits develop small voltage values across a high impedance circuit. A low impedance placed in parallel with the AGC circuit will reduce or destroy this voltage. For this reason, a voltmeter circuit with a relatively small input resistance cannot be used to measure the voltage present.

When your Model 262 is set at the 160 volt range, its input impedance is 3.2 megohms, and this is enough resistance that it may be placed across an AGC circuit to identify that

SPECIAL APPLICATIONS

there is voltage present, and to read its value satisfactorily. The marks represent steps of 2 volts each, and are separated far enough apart that the user can see 1 volt values easily.

MEASURING SMALL RESISTANCES

The 4.5 ohm center scale marking for the ohms scale has allowed identification of very small values of resistance. Each scale division on the right hand side of the scale represents only 1/20 of an ohm. With definite measurements of such small resistance values the condition of transformer windings and inductance coils can be identified quite easily.

The six resistance ranges allow easier identification of all resistance values within the range of the instrument. When you can obtain a reading on more than one resistance range, the more accurate value will be the one which produces the reading closer to center scale on the meter.

BIAS VOLTAGE MEASUREMENTS

Grid bias voltages are developed across high impedance circuits and have small values. The conditions are similar to those listed in the above paragraphs which discuss AGC voltage measurements. Again, you should use the 40 or 160 volt range of the Model 262 to minimize the loading effect of the meter circuit, while still being able to measure the bias voltage.

SPECIAL APPLICATIONS

CAPACITY MEASUREMENTS

The Model 262 can be used to measure capacity under some conditions. Figure 10 shows the circuit to use, and the meter indications and shunt resistor values are calculated for a 115 volt A.C. 60 cycle power input.

Small values of capacity have relatively high capacitive reactance, and will limit the total A.C. current through the meter circuit to a low value. Large capacities, with smaller reactances, allow more current to flow through the meter circuit to provide more deflection. In any case, much or most of the source voltage will be dropped across the capacitor being measured, and it must have a high enough voltage rating to withstand this stress or it will short out.

Do not measure electrolytics with this circuit; they are not designed for A.C. voltage applications.

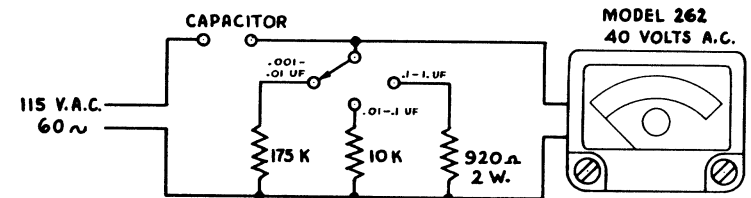

FIGURE 10. CIRCUIT USED TO MEASURE CAPACITY WITH THE MODEL 262

When a capacitor is placed in the indicated test position in the above circuit, its value will be indicated through the voltage reading on the voltmeter according to the following table.

SPECIAL APPLICATIONS

Approximate Reading	Capacity in Microfarads		
A.C. Volts on 40 VAC Range	Range Switch	Range Switch	Range Switch
	.001-.01	.01-.1	.1-1.
4	.001	.01	.1
8	.002	.02	.2
12	.003	.03	.3
16	.004	.04	.4
20	.005	.05	.5
24	.006	.06	.6
28	.007	.07	.7
32	.008	.08	.8
36	.009	.09	.9
40	.01	.1	1.0

**MIDGETESTER
Model 355**
AC-DC VOLT-OHMETER
SELF SHIELDED!
Fits in Your Shirt Pocket!
\$29⁹⁵
Leather Zipper
Case **\$2.95**

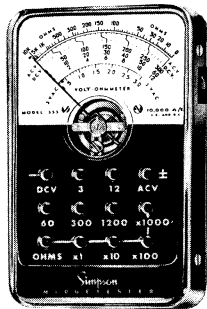

SPECIAL APPLICATIONS

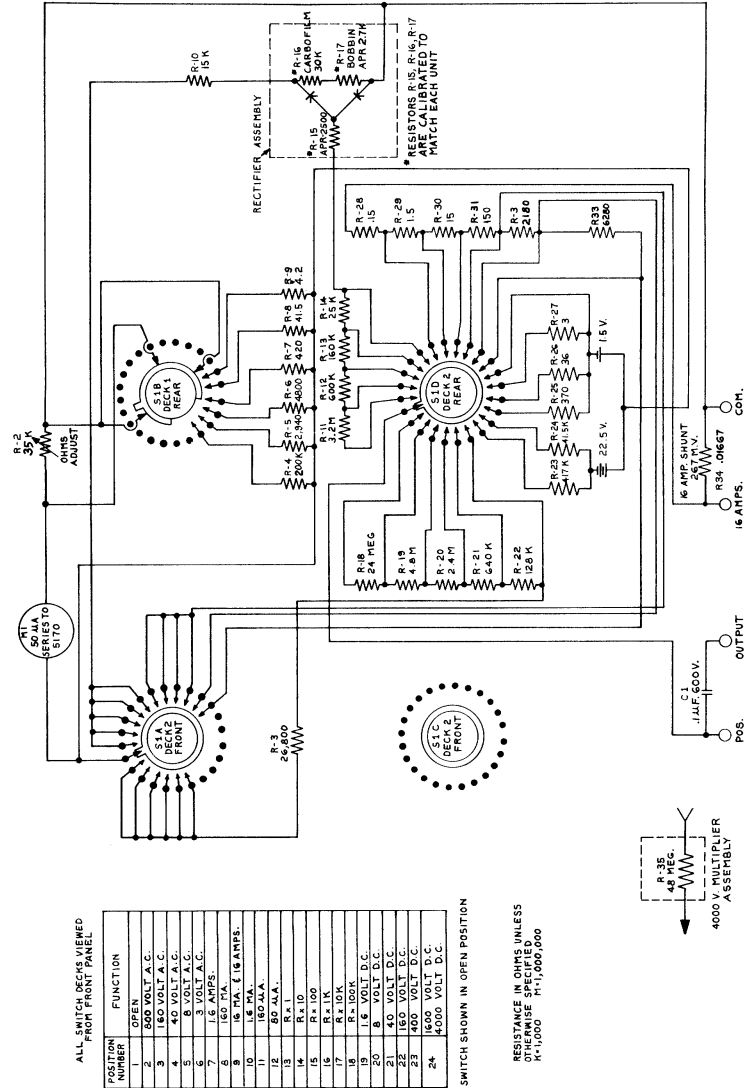

FIGURE 11. MODEL 262 SCHEMATIC DIAGRAM

SECTION V SUPPLEMENTARY DATA

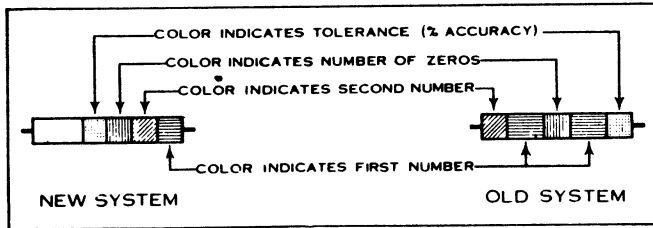

FIGURE 12. RMA RESISTOR COLOR CODE CHART

RMA RESISTOR COLOR CODE CHART

Color	Number	Color	Number
Black	0	Green	5
Brown	1	Blue	6
Red	2	Violet	7
Orange	3	Gray.....	8
Yellow.....	4	White.....	9

Gold (green-old system).....	5% tolerance
Silver (blue-old system)	10% tolerance
None	20% tolerance (Standard)

EXAMPLE: A 50,000 ohm resistor of standard tolerance is indicated by a green ring (5), a black ring (0) and an orange ring (000) as shown in the new system of marking in Figure 12. In the old system of marking, at the right of Figure 12, the resistor would be painted green (5) with a black end (0) and an orange dot or ring in the center (000).

SUPPLEMENTARY DATA

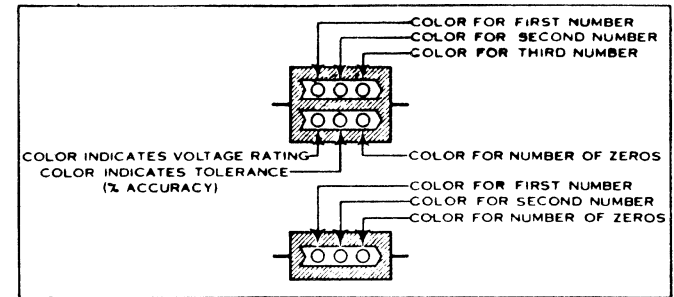

FIGURE 13. RMA MICA CAPACITOR COLOR CODE CHART

RMA MICA CAPACITOR COLOR CODE CHART

Color	Number	Tolerance	Voltage Rating
Black.....	0
Brown.....	1	1%	100
Red.....	2	2%	200
Orange.....	3	3%	300
Yellow.....	4	4%	400
Green.....	5	5%	500
Blue.....	6	6%	600
Violet.....	7	7%	700
Gray.....	8	8%	800
White.....	9	9%	900
Gold.....	5%	1000
Silver.....	10%	2000
None.....	20%	500

EXAMPLE: A 56,300 MMFD.(0.0563 MFD.) capacitor of 10% tolerance and a 500 volt rating is indicated by a green dot (5), a blue dot (6), and an orange dot (3), on the top row; a red dot (2 zeros) (00), a silver dot (10% tolerance) and a green dot (or no color) (500 volts) arranged in the order shown in Figure 13. All capacitance values are given in micro-microfarads (MMFD). To convert to microfarads (MFD) move the decimal point 6 places to the left. Small capacitors are often marked with 3 dots as shown in Figure 13. For example, a 250 MMFD. unit (.000250 MFD.) would be marked Red (2), green (5), and brown (1 zero) (0).

The RMA Condenser marking code is in wide use, although there will be some cases where other codes will be found.

SUPPLEMENTARY DATA

DECIBELS ABOVE AND BELOW REFERENCE LEVEL EXPRESSED IN WATTS AND VOLTS

Reference Level 1 milliwatt into 600 ohms

The power in watts holds for any impedance but the voltage holds only for 600 ohms.

DB Down		Power Level		DB Up	
Volts	Watts -	+	Volts	Watts	Volts
.7746	1.00x10 ⁻³	0	.7746	.001000	
.6897	.795x10 ⁻³	1	.8700	.001260	
.6150	.631x10 ⁻³	2	.9760	.001585	
.5490	.501x10 ⁻³	3	1.092	.001996	
.4980	.398x10 ⁻³	4	1.227	.002510	
.4352	.316x10 ⁻³	5	1.378	.003160	
.3880	.251x10 ⁻³	6	1.573	.003979	
.3455	.200x10 ⁻³	7	1.732	.005010	
.3083	.159x10 ⁻³	8	1.971	.006310	
.2750	.126x10 ⁻³	9	2.182	.007950	
.2448	1.00x10 ⁻⁴	10	2.448	.01000	
.2182	.795x10 ⁻⁴	11	2.750	.01260	
.1971	.631x10 ⁻⁴	12	3.083	.01585	
.1732	.501x10 ⁻⁴	13	3.458	.01996	
.1573	.398x10 ⁻⁴	14	3.879	.02510	
.1378	.316x10 ⁻⁴	15	4.360	.03160	
.1228	.251x10 ⁻⁴	16	4.985	.03979	
.1092	.200x10 ⁻⁴	17	5.488	.05010	
.0976	.159x10 ⁻⁴	18	6.150	.06310	
.0870	.126x10 ⁻⁴	19	6.897	.07950	
.07746	1.00x10 ⁻⁵	20	7.746	.1000	
.04352	.316x10 ⁻⁵	25	13.78	.3160	
.02448	1.00x10 ⁻⁶	30	24.48	1.000	
.01378	.316x10 ⁻⁶	35	43.60	3.160	
.007746	1.00x10 ⁻⁷	40	77.46	10.00	
.004352	.316x10 ⁻⁷	45	137.8	31.60	
.002448	1.00x10 ⁻⁸	50	244.8	100.0	

SUPPLEMENTARY DATA

CAPACITIVE REACTANCES (correct to three significant figures)

AUDIO FREQUENCIES

$$\text{Formula: } X_c = \frac{1}{2\pi f c}$$

Capacitance Microfarads	Reactance in ohms at:					
	30 c/s	60 c/s	100 c/s	400 c/s	1000 c/s	5000 c/s
.00005	---	---	---	---	---	637,000
.0001	---	---	---	---	---	318,000
.00025	---	---	---	1,590,000	1,590,000	127,000
.0005	---	---	3,180,000	796,000	318,000	63,700
.001	---	2,650,000	1,590,000	398,000	159,000	31,800
.005	1,060,000	530,834	318,000	79,600	31,800	6,370
.01	531,000	265,000	159,000	39,800	15,900	3,180
.02	263,000	132,500	79,600	19,900	7,960	1,590
.05	106,000	53,083	31,800	7,960	3,180	637
.1	53,100	26,500	15,900	3,980	1,590	318
.25	21,200	10,584	6,370	1,590	637	127
.5	10,600	5,308	3,180	796	318	63.7
1	5,310	2,650	1,590	389	159	31.8
2	2,650	1,325	796	199	79.6	15.9
4	1,310	663	398	99.5	39.8	7.96
8	663	332	199	49.7	19.9	3.98
16	332	166	99.5	24.9	9.95	1.99
25	212	106	63.7	15.9	6.37	1.27
35	152	86	45.5	11.4	4.55	.910

RADIO FREQUENCIES

$$\text{Formula: } X_c = \frac{1}{2\pi f c}$$

Capacitance Microfarads	Reactance in ohms at:					
	175 Kc/s	252 Kc/s	465 Kc/s	550 Kc/s	1000 Kc/s	1,500 Kc/s
.00005	18,200	12,600	6,850	5,800	3,180	2,120
.0001	9,100	6,320	3,420	2,900	1,590	1,060
.00025	3,640	2,530	1,370	1,160	637	424
.0005	1,820	1,260	685	579	318	212
.001	910	632	342	290	159	106
.005	182	126	68.5	57.9	31.8	21.2
.01	91.0	63.2	34.2	28.9	15.9	10.6
.02	45.5	31.6	17.1	14.5	7.96	5.31
.05	18.2	12.6	6.85	4.79	3.18	2.12
.1	9.10	6.32	3.42	2.89	1.59	1.06
.25	3.64	2.53	1.37	1.16	.637	.424
.5	1.82	1.26	.685	.579	.318	.212
1	.910	.632	.342	.289	.159	.106
2	.455	.316	.171	.145	.0796	.0531
4	.227	.158	.0856	.0723	.0398	.0265

Simpson 7" COLORSCOPE

MODEL 458

Seven big features make Model 458 the ideal scope for color TV servicing: (1) 7" Cathode Ray Tube; (2) On wide band operation, the frequency response is flat within 1.5 db to 4.5 Mc. Will faithfully display COLOR BURST frequency with a sensitivity greater than 30 Mv rms per inch of vertical deflection; (3) On narrow band operation, the frequency response is flat within 3 db from 10 cycles to 300 Kc with a sensitivity greater than 10 Mv rms per inch; (4) Good square wave response provides accurate representation of sync pulses and composite wave-form pattern for trouble-shooting video, sync, and sweep circuits; (5) Horizontal Sweep, to 200 Kc, for expansion of high frequency wave-form detail and color burst; (6) Vernier and Compensated Decimal Step Attenuator for better signal controls and (7) Provision for Intensity Modulation of CRT.

Size: 11 x 16½ x 14½ High. **Weight:** 29 lbs.

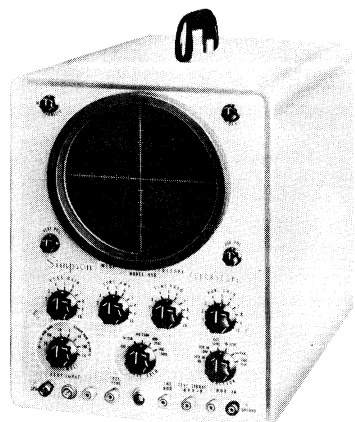

NEW!

Model 458
complete with
Operator's Manual

\$229⁹⁵

Scope Calibrator Model 276 adapts your scope for voltage measurements.

RMS: .36, .9, 3.6, 9, 36, 90.

PEAK: .50, 1.25, 5, 12.5, 50, 125.

PEAK to PEAK: 1.0, 2.50, 10, 25, 100, 250.

POWER: 105-125V. 50-60 Cycles.

Model 276 with Operator's Manual..... **\$29⁵⁰**

WARRANTY

SIMPSON ELECTRIC COMPANY warrants each instrument and other articles of equipment manufactured by it to be free from defects in material and workmanship under normal use and service, its obligation under this warranty being limited to making good at its factory any instrument or other article of equipment which shall within 90 days after delivery of such instrument or other article of equipment to the original purchaser be returned intact to it, or to one of its authorized service stations, with transportation charges prepaid, and which its examination shall disclose to its satisfaction to have been thus defective; this warranty being expressly in lieu of all other warranties expressed or implied and of all other obligations or liabilities on its part, and SIMPSON ELECTRIC COMPANY neither assumes nor authorizes any other persons to assume for it any other liability in connection with the sale of its products.

This warranty shall not apply to any instrument or other article of equipment which shall have been repaired or altered outside the SIMPSON ELECTRIC COMPANY factory or authorized service stations, nor which has been subject to misuse, negligence or accident, incorrect wiring by others, or installation or use not in accord with instructions furnished by the manufacturer.

Simpson ELECTRIC COMPANY

5200 Kinzie St., Chicago 44, Illinois • Phone: EStebrook 9-1121

In Canada: Bach-Simpson, Ltd., London, Ontario



LAC DU FLAMBEAU PLANT
WISCONSIN



LAKE STREET PLANT
CHICAGO



KINZIE STREET PLANT
CHICAGO



AURORA PLANT
AURORA, ILL.