

(*) - 1W.
 (#) - 2W.
 (+) - 5W.

Title			
PRE AMPLIFICADOR EQ 2 VIAS			
Size	Number	Rev	
A2	PREEQ2	1	
Date	12/05/09	Drawn by	OAF&JRC
Filename	PREEOP.S01	Sheet	1 of 1

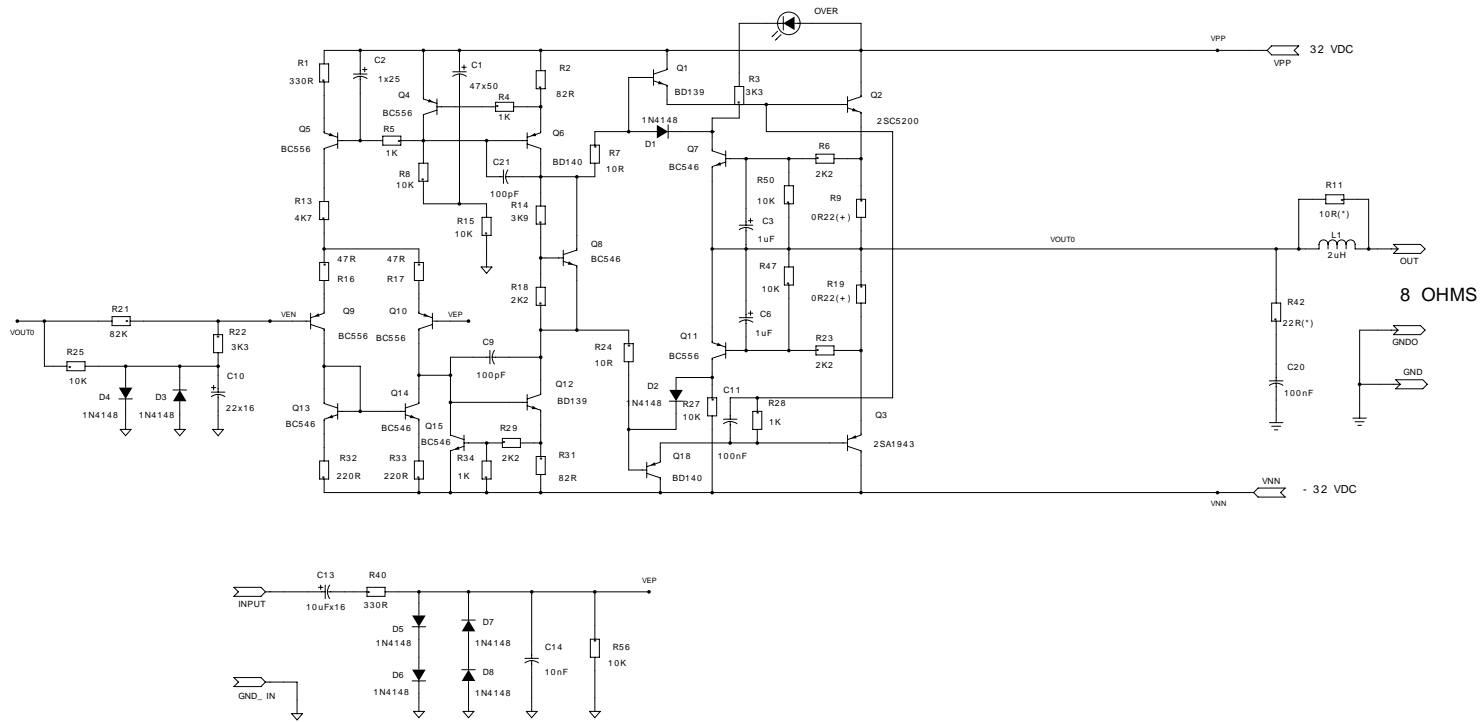

(*) - 2W.
 (+) - 5W.

Title			
AMPLIFICADOR 150W RMS			
Size	Number	Rev	
A2	CLARITY 10 POLEGADAS	1	
Date	19/01/10	Drawn by	OAF&JRC
Filename	CLARI10P.S01	Sheet	1 of 1

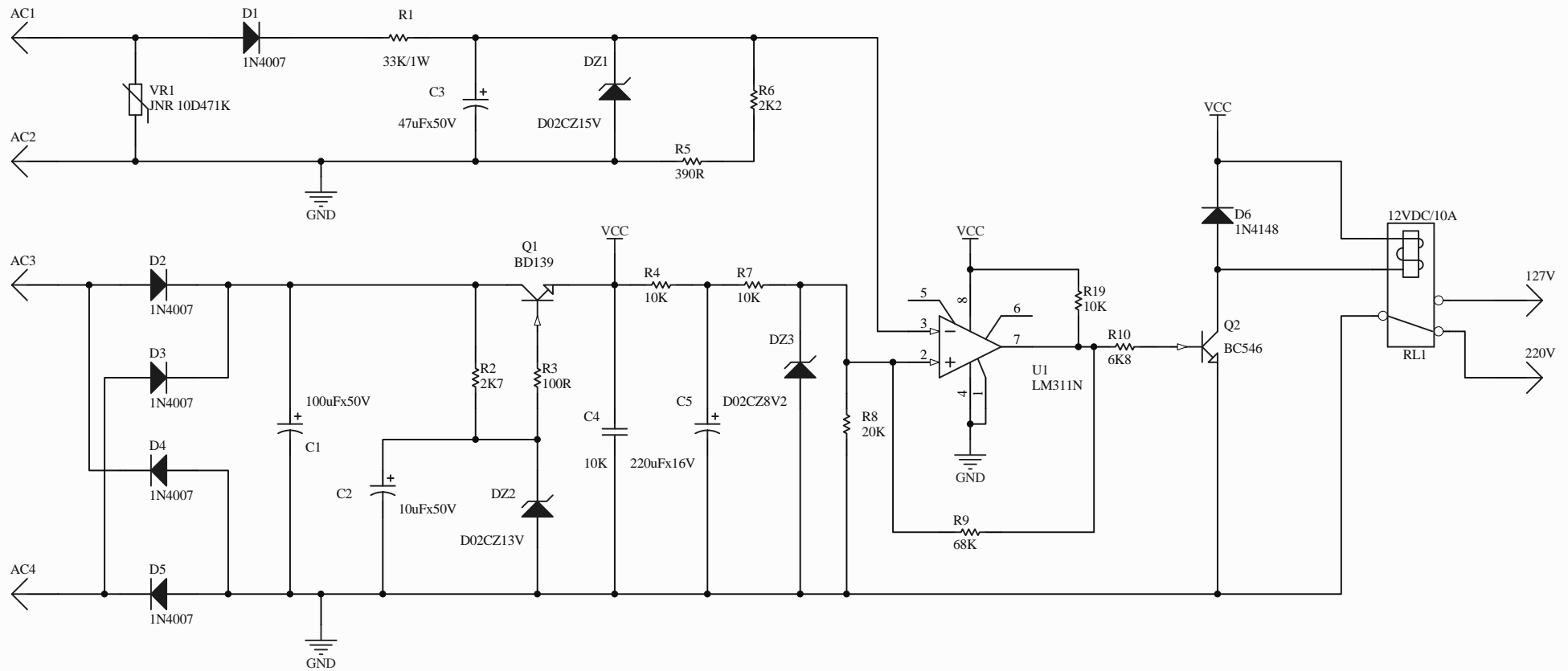

Title			
MULTI VOLT 2011			
Size	Number	Revision	
A4	MV01	1	
Date:	22/08/2012	Sheet of	1
File:	B:\Placas Para Inserção Automática...\Multi Volt 2011.SchDoc		

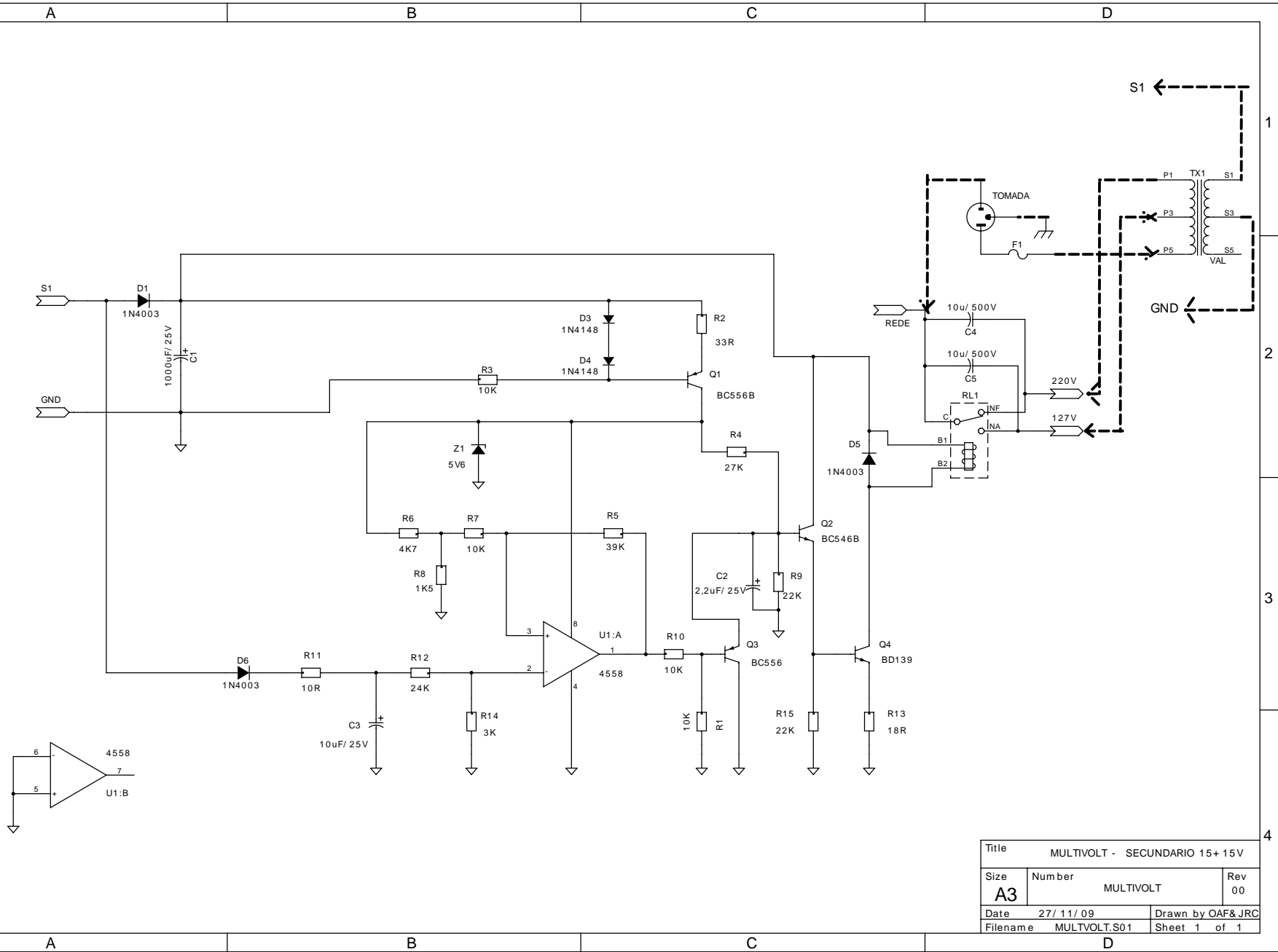

Title			MULTIVOLT - SECUNDARIO 15+ 15V
Size	Number	Rev	
A3	MULTIVOLT	00	
Date	27/ 11/ 09	Drawn by OAF&JRC	
Filename	MULTIVOLT.S01	Sheet 1 of 1	