

# DCR-HC52

## MANUAL DE SERVIÇO

LEVEL 2

Brazillian Model

Ver. 1.0 2007.12

Revision History



N MECHANISM (MDX-N220)

Foto: DCR-HC52

### Link

• ESPECIFICAÇÕES	• DESMONTAGEM	• DIAGRAMAS ESQUEMATICOS
• TABELA DE INFORMAÇÃO DO MODELO	• DIAGRAMAS EM BLOCOS	• PLACAS DE CIRCUITO IMPRESSO
• NOTA DE SERVIÇO	• DIAGRAMAS ESQUEMÁTICOS DA ESTRUTURA	• LISTA DE PEÇAS PARA REPARO

### • PRECAUÇÃO EM SUBSTITUIR A PLACA VC-537

The components identified by mark  $\Delta$  or dotted line with mark  $\Delta$  are critical for safety. Replace only with part number specified.

Les composants identifiés par une marque  $\Delta$  sont critiques pour la sécurité. Ne les remplacer que par une pièce portant le numéro spécifié.

Mini DV Digital Video Cassette

## DIGITAL VIDEO CAMERA RECORDER

# SONY®

These specifications are extracted from instruction manual of DCR-HC52/HC54.



## ESPECIFICAÇÕES

### System

#### Video recording system

2 rotary heads, Helical scanning system

#### Audio recording system

Rotary heads, PCM system  
Quantization: 12 bits (Fs 32 kHz, stereo 1, stereo 2), 16 bits (Fs 48 kHz, stereo)

#### Video signal

NTSC color, EIA standards

#### Usable cassette

Mini DV cassette with the <sup>Mini</sup>DV mark printed

#### Tape speed

SP: Approx. 18.81 mm/s  
LP: Approx. 12.56 mm/s

#### Recording/playback time

SP: 60 min (using a DVM60 cassette)  
LP: 90 min (using a DVM60 cassette)

#### Fast forward/rewind time

Approx. 2 min 40 s (using a DVM60 cassette and rechargeable battery pack)  
Approx. 1 min 45 s (using a DVM60 cassette and AC Adaptor)

#### Viewfinder

Electric viewfinder (color)

#### Image device

3.0 mm (1/6 type) CCD (Charge Coupled Device)  
Gross: Approx. 680 000 pixels  
Effective (movie): Approx. 340 000 pixels

#### Lens

Carl Zeiss Vario-Tessar  
40 × (Optical), 2 000 × (Digital)

#### Focal length

f=1.9 ~ 76 mm (3/32 ~ 3 in.)  
When converted to a 35 mm still camera  
In CAMERA: 36 ~ 1 440 mm (1 7/16 ~ 56 3/4 in.)  
F1.8 ~ 4.1  
Filter diameter: 30 mm (1 3/16 in.)

#### Color temperature

[AUTO], [ONE PUSH], [INDOOR] (3 200 K), [OUTDOOR] (5 800 K)

#### Minimum illumination

11 lx (lux) (F 1.8)  
0 lx (lux) (during NightShot plus function)

### Input/Output connectors

#### A/V Remote Connector

10-pin connector  
Video signal: 1 Vp-p, 75Ω (ohms)  
Luminance signal: 1 Vp-p, 75Ω (ohms)  
Chrominance signal: 0.286 Vp-p, 75Ω (ohms)  
Audio signal: 327 mV (at load impedance 47 kΩ (kilohms)), Output impedance with less than 2.2 kΩ (kilohms)

#### USB jack (DCR-HC54)

mini-B

#### DV input/output jack

i.LINK Interface (IEEE1394, 4-pin connector S100)

### LCD screen

#### Picture

6.2 cm (2.5 type)

#### Total dot number

123 200 (560 × 220)

### General

#### Power requirements

DC 6.8 V/7.2 V (battery pack)  
DC 8.4 V (AC Adaptor)

#### Average power consumption

During camera recording using the viewfinder 1.8 W  
During camera recording using the LCD 2.1 W

#### Operating temperature

0 °C to 40 °C (32 °F to 104 °F)

#### Storage temperature

-20 °C to +60 °C (-4 °F to +140 °F)

#### Dimensions (approx.)

63 × 85 × 114 mm  
(2 1/2 × 3 3/8 × 4 1/2 in.) (w/h/d) including the projecting parts  
63 × 85 × 115 mm  
(2 1/2 × 3 3/8 × 4 5/8 in.) (w/h/d) including the projecting parts with supplied battery pack NP-FH30 attached

#### Mass (approx.)

380g(13oz) main unit only  
440g(15oz) including the NP-FH30 rechargeable battery pack and DVM60 cassette.

### Supplied accessories

AC Adaptor (1)  
Power cord (Mains lead) (1)  
A/V connecting cable (1)  
USB cable (1)  
(DCR-HC54)  
Rechargeable battery pack NP-FH30 (1)  
CD-ROM "Handycam Application Software" (1)(DCR-HC54)  
Operating Guide (1)

### AC Adaptor AC-L200/L200B

#### Power requirements

AC 100 V - 240 V, 50/60 Hz

#### Current consumption

0.35 - 0.18 A

#### Power consumption

18 W

#### Output voltage

DC 8.4 V\*

#### Operating temperature

0 °C to 40 °C (32 °F to 104 °F)

#### Storage temperature

-20 °C to +60 °C (-4 °F to +140 °F)

#### Dimensions (approx.)

48 × 29 × 81 mm (1 15/16 × 1 3/16 × 3 1/4 in.) (w/h/d) excluding the projecting parts

#### Mass (approx.)

170 g (6.0 oz) excluding the power cord (mains lead)

\* See the label on the AC Adaptor for other specifications.

### Rechargeable battery pack (NP-FH30)

#### Maximum output voltage

DC 8.4 V

#### Output voltage

DC 7.2 V

#### Capacity

3.6 Wh (500 mAh)

#### Dimensions (approx.)

31.8 × 18.5 × 45.0 mm  
(1 5/16 × 3/4 × 1 13/16 in) (w/h/d)

#### Mass (approx.)

40 g (1.5 oz)

#### Operating temperature

0 °C to 40 °C (32 °F to 104 °F)

#### Type

Lithium ion

Design and specifications are subject to change without notice.

**CAUTION**

Danger of explosion if battery is incorrectly replaced.  
Replace only with the same or equivalent type.

**SAFETY-RELATED COMPONENT WARNING!!**

**COMPONENTS IDENTIFIED BY MARK  $\triangle$  OR DOTTED LINE WITH MARK  $\triangle$  ON THE SCHEMATIC DIAGRAMS AND IN THE PARTS LIST ARE CRITICAL TO SAFE OPERATION. REPLACE THESE COMPONENTS WITH SONY PARTS WHOSE PART NUMBERS APPEAR AS SHOWN IN THIS MANUAL OR IN SUPPLEMENTS PUBLISHED BY SONY.**

**ATTENTION AU COMPOSANT AYANT RAPPORT  
À LA SÉCURITÉ!**

**LES COMPOSANTS IDENTIFIÉS PAR UNE MARQUE  $\triangle$  SUR LES DIAGRAMMES SCHÉMATIQUES ET LA LISTE DES PIÈCES SONT CRITIQUES POUR LA SÉCURITÉ DE FONCTIONNEMENT. NE REMPLACER CES COMPOSANTS QUE PAR DES PIÈCES SONY DONT LES NUMÉROS SONT DONNÉS DANS CE MANUEL OU DANS LES SUPPLÉMENTS PUBLIÉS PAR SONY.**

## SAFETY CHECK-OUT

After correcting the original service problem, perform the following safety checks before releasing the set to the customer.

1. Check the area of your repair for unsoldered or poorly-soldered connections. Check the entire board surface for solder splashes and bridges.
2. Check the interboard wiring to ensure that no wires are "pinched" or contact high-wattage resistors.
3. Look for unauthorized replacement parts, particularly transistors, that were installed during a previous repair. Point them out to the customer and recommend their replacement.
4. Look for parts which, through functioning, show obvious signs of deterioration. Point them out to the customer and recommend their replacement.
5. Check the B+ voltage to see it is at the values specified.
6. Flexible Circuit Board Repairing
  - Keep the temperature of the soldering iron around 270°C during repairing.
  - Do not touch the soldering iron on the same conductor of the circuit board (within 3 times).
  - Be careful not to apply force on the conductor when soldering or unsoldering.

### Unleaded solder

Boards requiring use of unleaded solder are printed with the lead-free mark (LF) indicating the solder contains no lead.

(Caution: Some printed circuit boards may not come printed with the lead free mark due to their particular size.)

### : LEAD FREE MARK

Unleaded solder has the following characteristics.

- Unleaded solder melts at a temperature about 40°C higher than ordinary solder.  
Ordinary soldering irons can be used but the iron tip has to be applied to the solder joint for a slightly longer time.  
Soldering irons using a temperature regulator should be set to about 350°C.  
Caution: The printed pattern (copper foil) may peel away if the heated tip is applied for too long, so be careful!
- Strong viscosity  
Unleaded solder is more viscous (sticky, less prone to flow) than ordinary solder so use caution not to let solder bridges occur such as on IC pins, etc.
- Usable with ordinary solder  
It is best to use only unleaded solder but unleaded solder may also be added to ordinary solder.

# 1. NOTA DE SERVIÇO

## 1-1. POWER SUPPLY DURING REPAIRS

In this unit, about 10 seconds after power is supplied to the battery terminal using the regulated power supply (8.4V), the power is shut off so that the unit cannot operate.

The following method is available to prevent this.

### Method:

Use the AC power adaptor (AC-L200/L200B).

## 1-2. TO TAKE OUT A CASSETTE WHEN NOT EJECT (FORCE EJECT)

- ① Refer to "2. DISASSEMBLY" to remove the mechanism deck block.
- ② Supply +4.5V from the DC power supply to the loading motor and unload with a pressing the cassette compartment.

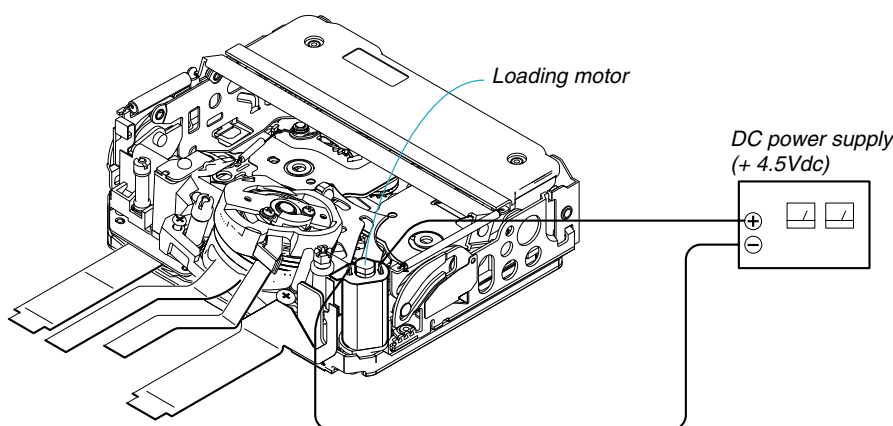

## 1-3. SETTING THE "FORCED POWER ON" MODE

It is possible to turn on power by adjustment remote commander (RM-95 or NEW LANC JIG). Operate the VTR function using the adjustment remote commander.

### 1-3-1. Setting the "Forced Camera Power ON" Mode

- 1) Select page: 0, address: 01, and set data:01.
- 2) Select page: A, address: 10, set data:01 and press the "PAUSE (Write)" button of the adjustment remote commander.

### 1-3-2. Setting the "Forced VTR Power ON" Mode

- 1) Select page: 0, address: 01, and set data:01.
- 2) Select page: A, address: 10, set data:02 and press the "PAUSE (Write)" button of the adjustment remote commander.

### 1-3-3. Exiting the "Forced Power ON" Mode

- 1) Select page: 0, address: 01, and set data:01.
- 2) Select page: A, address: 10, set data:00 and press the "PAUSE (Write)" button of the adjustment remote commander.
- 3) Select page: 0, address: 01, and set data: 00.

## 1-4. USING SERVICE JIG

Connect the CPC-15 jig connector (J-6082-564-A) and I/F unit for LANC control (J-6082-521-A) to the CN1014 of VC-537 board.

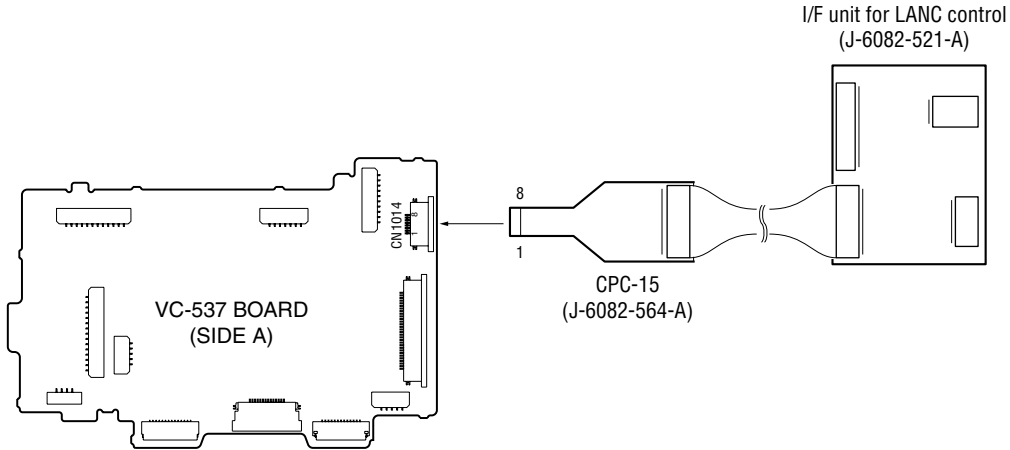

## 1-5. SELF-DIAGNOSIS FUNCTION

### 1-5-1. Self-diagnosis Function

When problems occur while the unit is operating, the self-diagnosis function starts working, and displays on the viewfinder or LCD screen what to do.

Details of the self-diagnosis functions are provided in the Instruction manual.

### 1-5-2. Self-diagnosis Display

When problems occur while the unit is operating, the counter of the viewfinder or LCD screen shows a 4-digit display consisting of an alphabet and numbers, which blinks at 3.2 Hz. This 5-character display indicates the “repaired by:”, “block” in which the problem occurred, and “detailed code” of the problem.

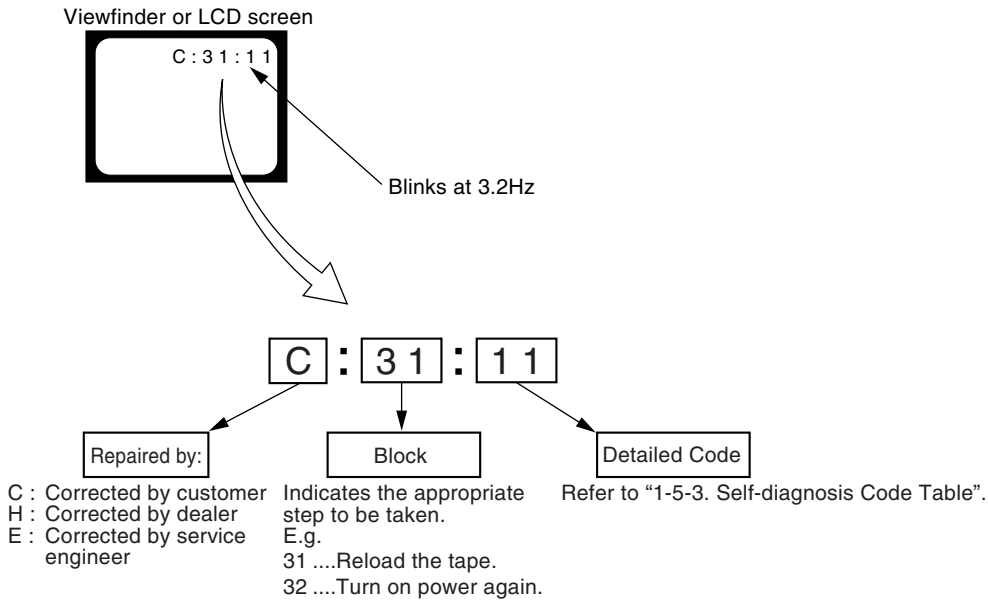

### 1-5-3. Tabela de código para Auto Diagnóstico

Repaired by:	Self-diagnosis Code			Symptom/State	Correction
	Block Function	Detailed Code			
C	0 4	0 0		Non-standard battery is used.	Use the InfoLITHIUM battery.
C	2 1	0 0		Condensation.	Remove the cassette, and insert it again after one hour.
C	2 2	0 0		Video head is dirty.	Clean with the optional cleaning cassette.
C	3 1	1 0		LOAD direction. Loading does not complete within specified time	Load the tape again, and perform operations from the beginning.
C	3 1	1 1		UNLOAD direction. Loading does not complete within specified time	Load the tape again, and perform operations from the beginning.
C	3 1	2 0		T reel side tape slacking when unloading.	Load the tape again, and perform operations from the beginning.
C	3 1	2 1		S reel side tape slacking when unloading.	Load the tape again, and perform operations from the beginning.
C	3 1	2 2		T reel fault.	Load the tape again, and perform operations from the beginning.
C	3 1	2 3		S reel fault.	Load the tape again, and perform operations from the beginning.
C	3 1	3 0		FG fault when starting capstan.	Load the tape again, and perform operations from the beginning.
C	3 1	3 1		FG fault during normal capstan operations.	Load the tape again, and perform operations from the beginning.
C	3 1	4 0		FG fault when starting drum.	Load the tape again, and perform operations from the beginning.
C	3 1	4 1		PG fault when starting drum.	Load the tape again, and perform operations from the beginning.
C	3 1	4 2		FG fault during normal drum operations.	Load the tape again, and perform operations from the beginning.
C	3 1	4 3		PG fault during normal drum operations.	Load the tape again, and perform operations from the beginning.
C	3 1	4 4		Phase fault during normal drum operations.	Load the tape again, and perform operations from the beginning.
C	3 2	1 0		LOAD direction loading motor time-out.	Remove the battery or power cable, connect, and perform operations from the beginning.
C	3 2	1 1		UNLOAD direction loading motor time-out.	Remove the battery or power cable, connect, and perform operations from the beginning.
C	3 2	2 0		T reel side tape slacking when unloading.	Remove the battery or power cable, connect, and perform operations from the beginning.
C	3 2	2 1		S reel side tape slacking when unloading.	Remove the battery or power cable, connect, and perform operations from the beginning.
C	3 2	2 2		T reel fault.	Remove the battery or power cable, connect, and perform operations from the beginning.
C	3 2	2 3		S reel fault.	Remove the battery or power cable, connect, and perform operations from the beginning.
C	3 2	3 0		FG fault when starting capstan.	Remove the battery or power cable, connect, and perform operations from the beginning.
C	3 2	3 1		FG fault during normal capstan operations.	Remove the battery or power cable, connect, and perform operations from the beginning.
C	3 2	4 0		FG fault when starting drum.	Remove the battery or power cable, connect, and perform operations from the beginning.
C	3 2	4 1		PG fault when starting drum.	Remove the battery or power cable, connect, and perform operations from the beginning.
C	3 2	4 2		FG fault during normal drum operations.	Remove the battery or power cable, connect, and perform operations from the beginning.
C	3 2	4 3		PG fault during normal drum operations.	Remove the battery or power cable, connect, and perform operations from the beginning.
C	3 2	4 4		Phase fault during normal drum operations.	Remove the battery or power cable, connect, and perform operations from the beginning.

Self-diagnosis Code			Symptom/State	Correction
Repaired by:	Block Function	Detailed Code		
E	6 1	0 0	Difficult to adjust focus (Cannot initialize focus.)	Inspect the lens block focus reset sensor (Pin ⑦, of CN3101 of VC-537 board) when focusing is performed when the touch panel is operated in the focus manual mode and the focus motor drive circuit (IC3101 of VC-537 board) when the focusing is not performed.
E	6 1	1 0	Zoom operations fault (Cannot initialize zoom lens.)	Inspect the lens block zoom reset sensor (Pin ⑩, of CN3101 of VC-537 board) when zooming is performed when the zoom switch is operated and the zoom motor drive circuit (IC3101 of VC-537 board) when zooming is not performed.
E	6 1	1 1	Focus lens initializing failure and zoom lens initializing failure occur simultaneously.	Inspect the flexible board for breakage or loose connection. If not faulty, inspect the focus and zoom motor drive circuit (IC3101 of VC-537 board).

## 1-6. PRECAUÇÃO EM SUBSTITUIR A PLACA VC-537

### Exif Model Data Check

When you replace to the repairing board, the written data of repairing board also might be changed to original setting.

When the data has changed because of board replacing etc, check the data setting (Exif Model Data) is right. If not, rewrite to the right value.

### Exif Model Data

Page	Address	Data					
		DCR-HC51E	DCR-HC52	DCR-HC52E	DCR-HC53E	DCR-HC54	DCR-HC54E
C	D2	35	35	35	35	35	35
C	D3	31	32	32	33	34	34
C	D4	45	00	45	45	00	45

### Writing Method:

1) Select page: 0, address: 01 and set data: 01.

2) Select page: C, address: D2 to D4, and set the Exif Model Data.

**Note:** To write in the non-volatile memory (EEPROM), press the PAUSE (Write) button each time to set the data.

3) Select page: 0, address: 01, and set data: 00.

## 2. DESMONTAGEM

### NOTA PARA REPARO

- Make sure that the flat cable and flexible board are not cracked or bent at the terminal.  
Do not insert the cable insufficiently nor crookedly.
- When remove a connector, don't pull at wire of connector. It is possible that a wire is snapped.
- When installing a connector, don't press down at wire of connector.  
It is possible that a wire is snapped.

Cut and remove the part of gilt which comes off at the point.  
(Be careful or some pieces of gilt may be left inside)

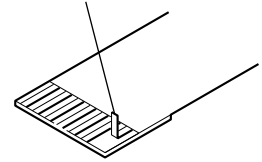



## 2-1. IDENTIFICANDO AS PEÇAS

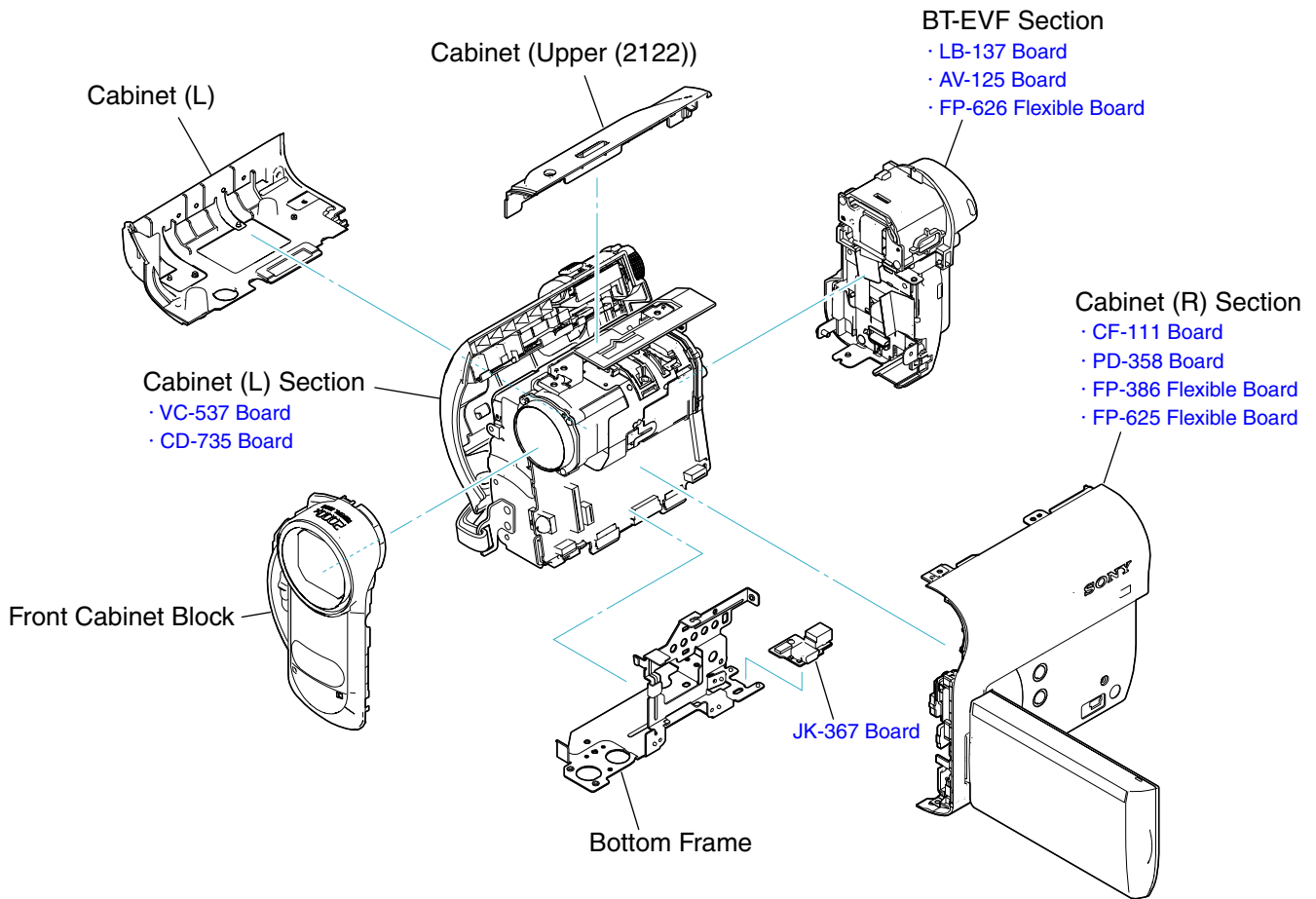

### - DISASSEMBLY FLOW -

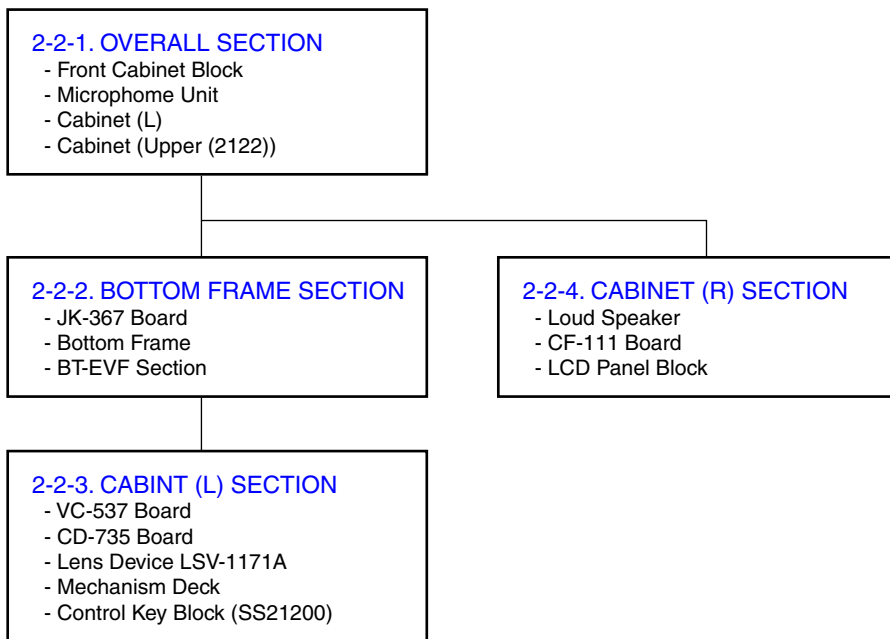

## 2-2. DESMONTAGEM

VISTA EXPLODIDA

LISTA DE PARAFUSOS

### 2-2-1. SEÇÃO GERAL

Follow the disassembly in the numerical order given.

- ① Cabinet (R) Section (①-1 to ①-14)
- ② Front Cabinet Block (②-1 to ②-6)

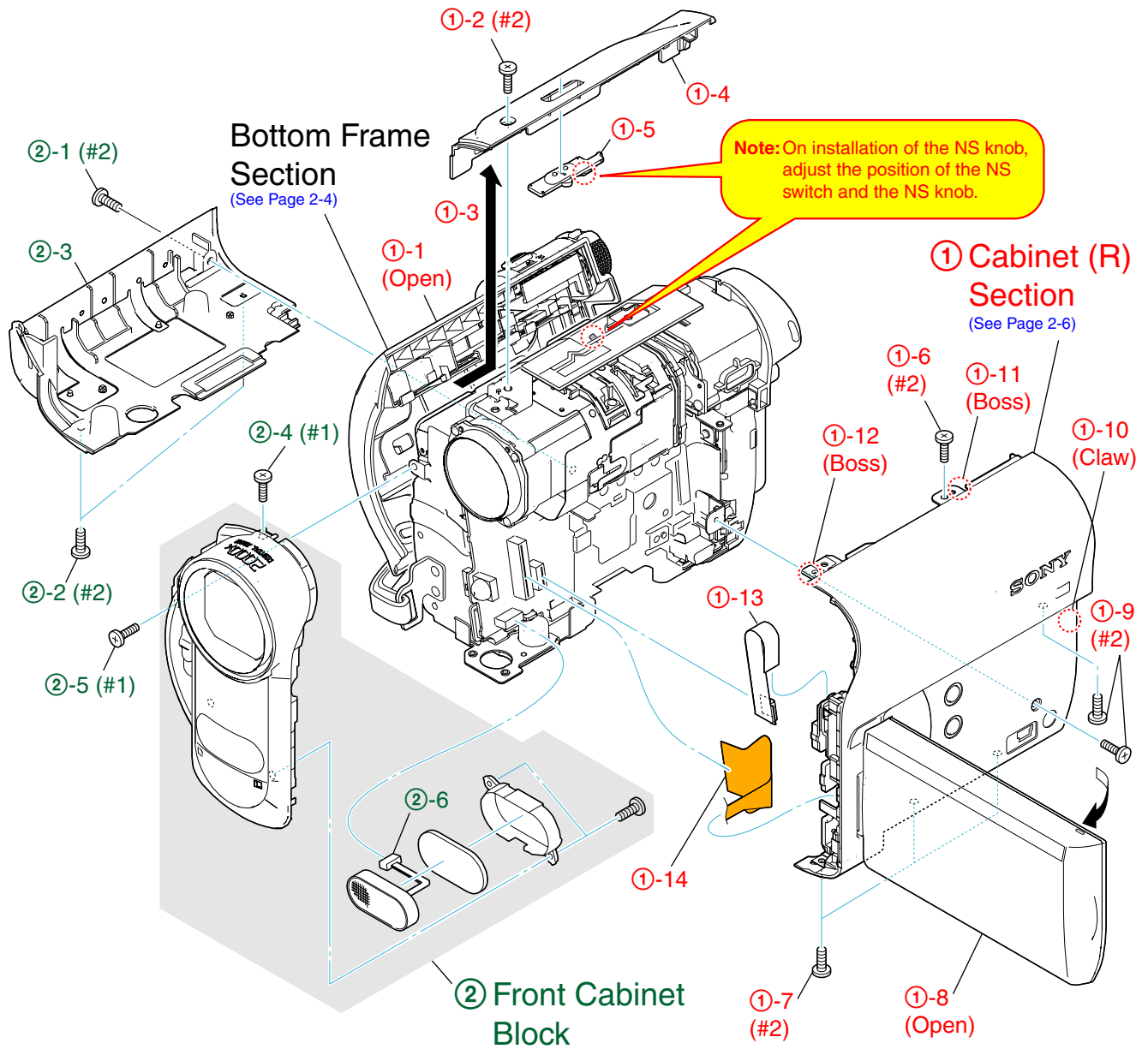

## 2-2-2. SEÇÃO DA ESTRUTURA INFERIOR

Follow the disassembly in the numerical order given.

- ① BT-EVF Section (①-1 to ①-3)
- ② JK-367 Board (②-1 to ②-7)

VISTA EXPLODIDA

LISTA DE PARAFUSOS

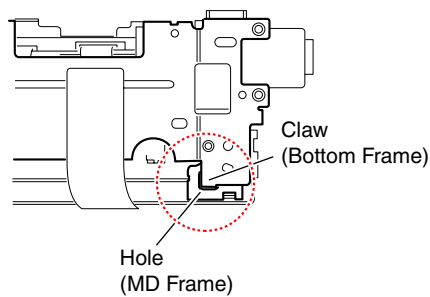
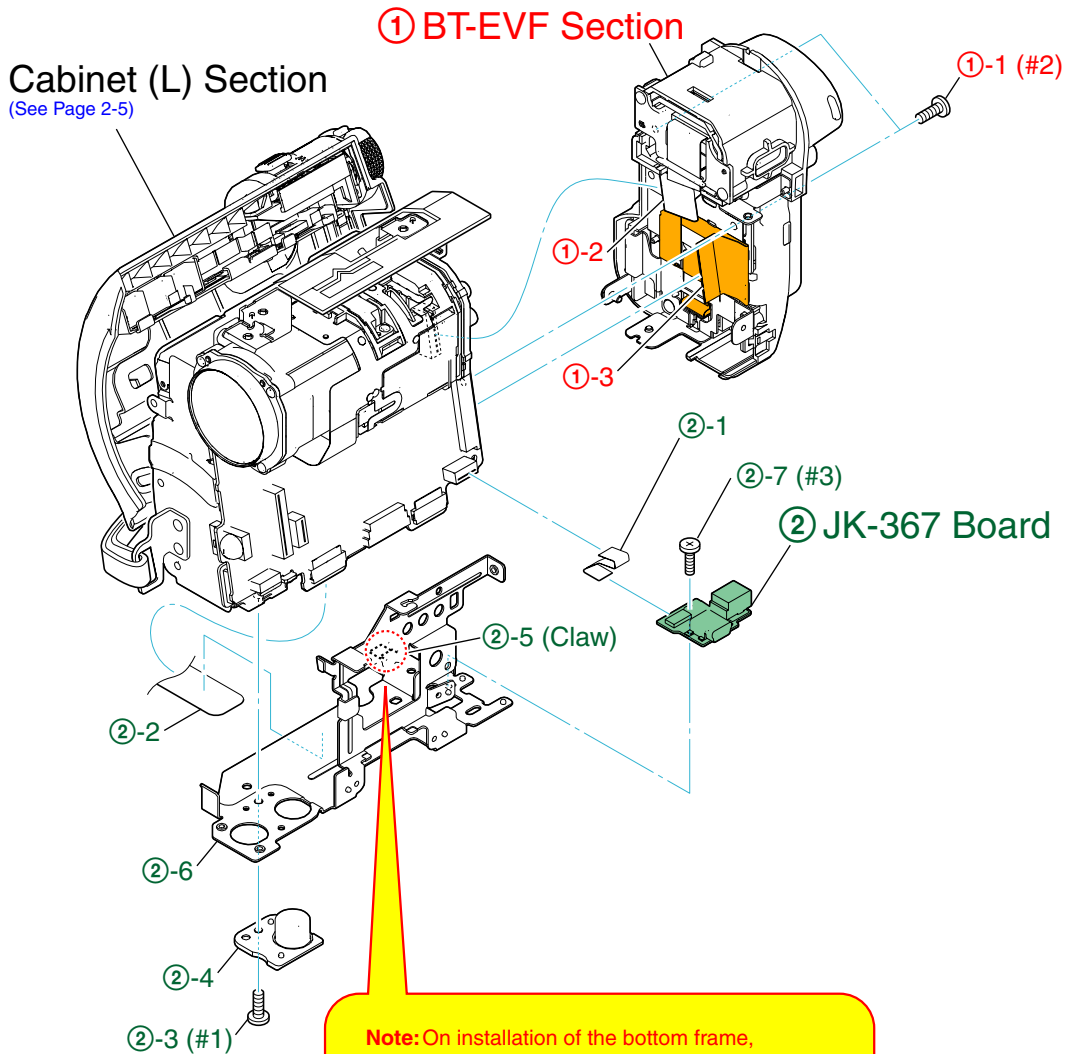

### 2-2-3. SEÇÃO DO GABINETE ESQUERDO (L)

Follow the disassembly in the numerical order given.

- ① Lens Block (①-1 to ①-3)
- ② VC-537 Board (②-1 to ②-8)
- ③ Mechanism Deck (③-1 to ③-3)

VISTA EXPLODIDA

LISTA DE PARAFUSOS

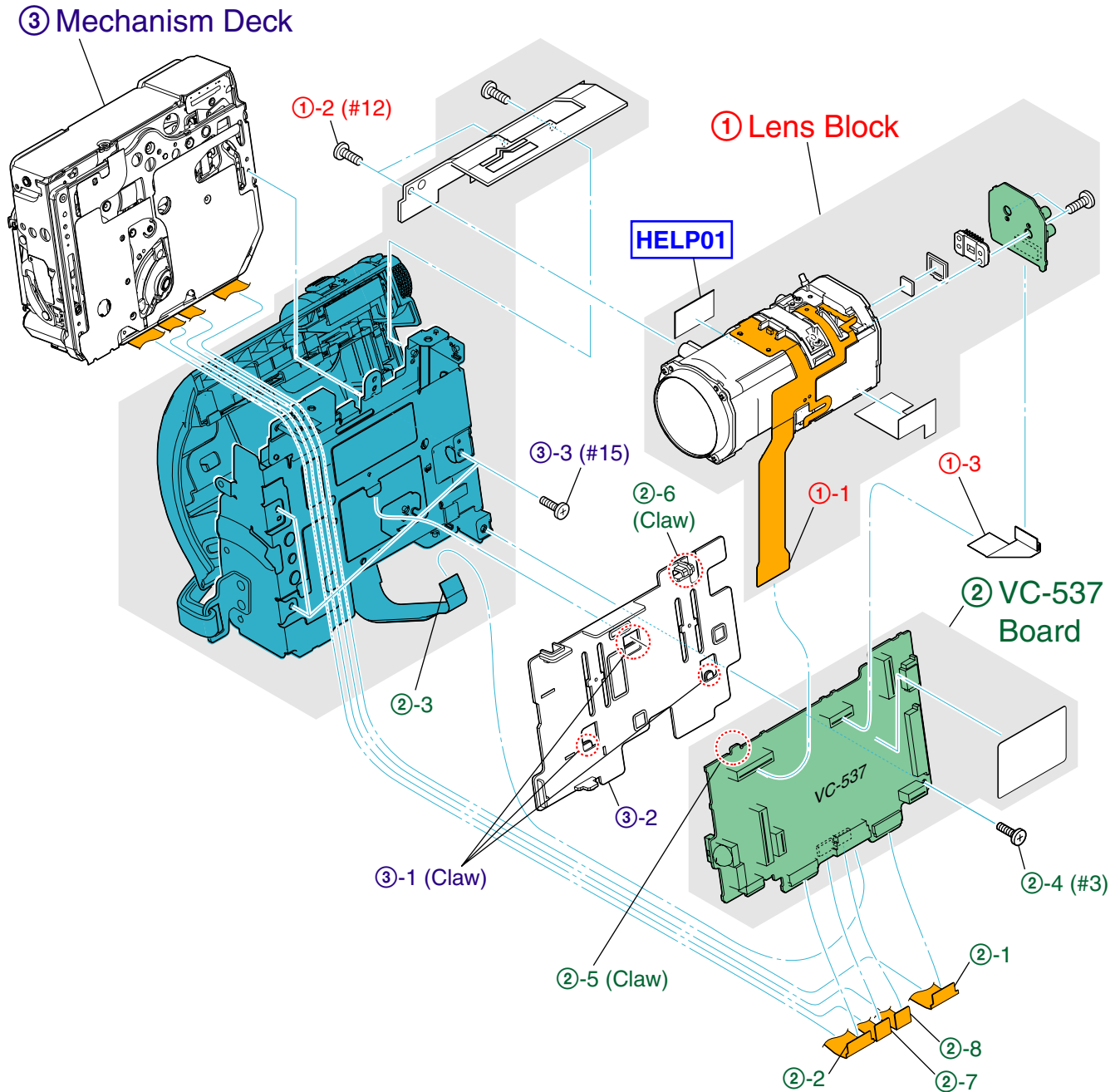

## 2-2-4. SEÇÃO DO GABINETE DIREITO (R)

Follow the disassembly in the numerical order given.

- ① CF-111 Board (①-1 to ①-7)
- ② LCD Panel Block (②-1 to ②-4)

VISTA EXPLODIDA

LISTA DE PARAFUSOS

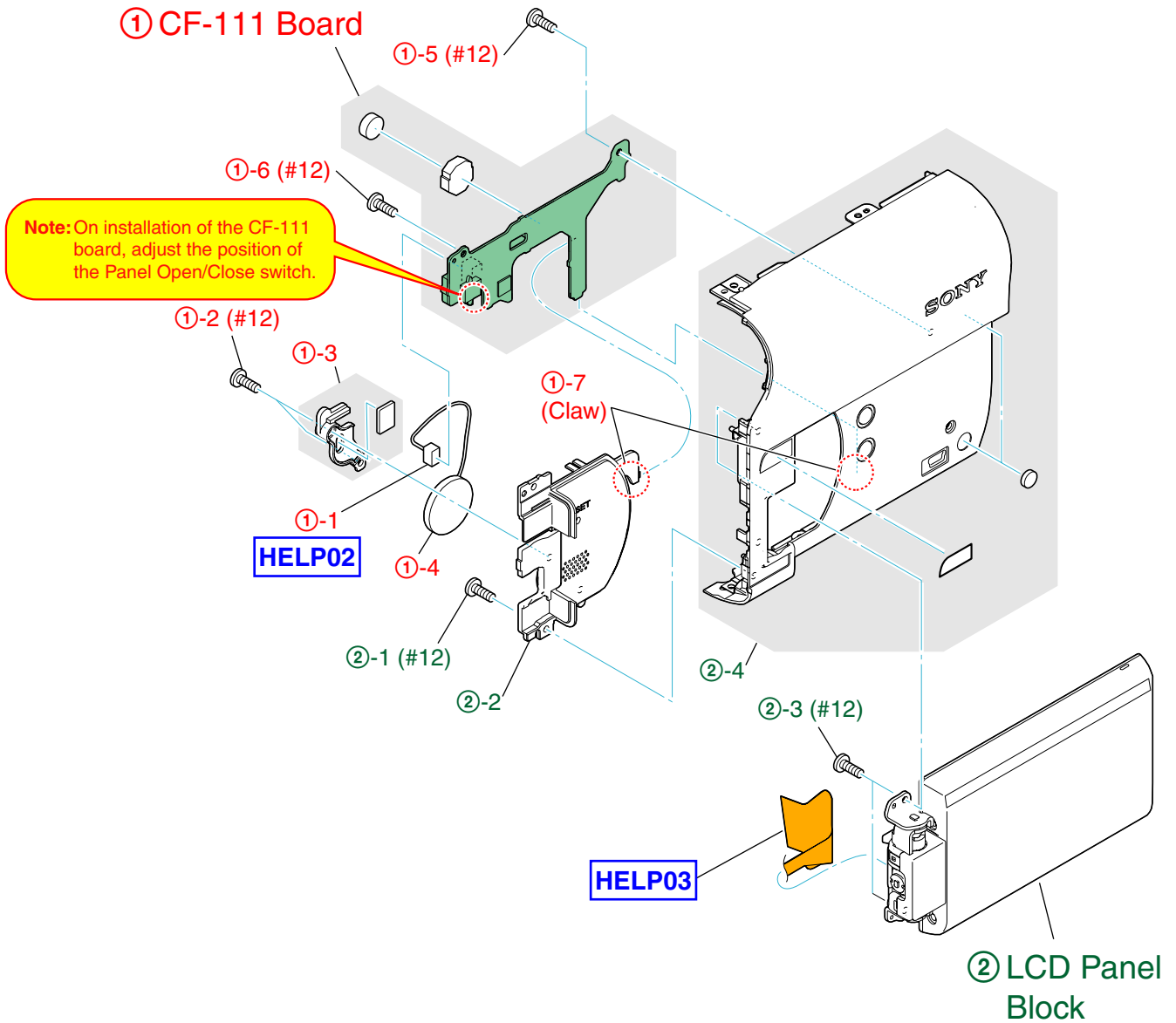

# AJUDA

Sheet attachment positions and procedures of processing the flexible boards/harnesses are shown.

**HELP01**

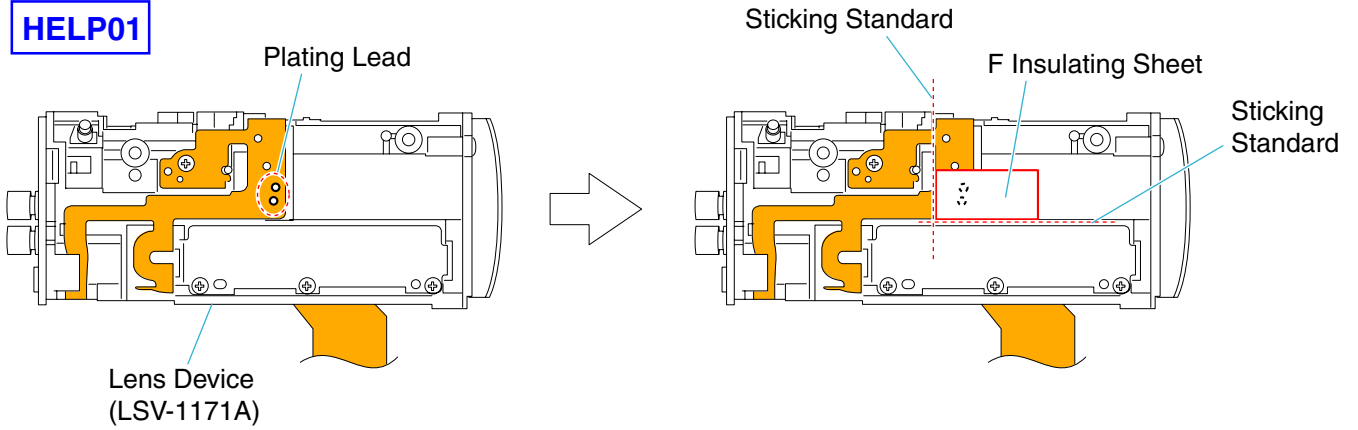

**HELP02**

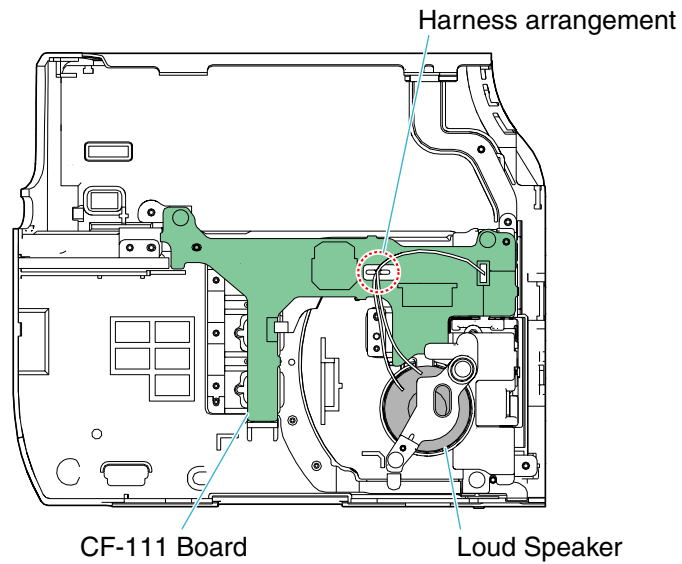

## HELP03

### O MÉTODO DE DOBRAMENTO DA PLACA FLEXÍVEL FP-625

- ① Fold dotted line parts of the FP-625 flexible board as shown in figure.

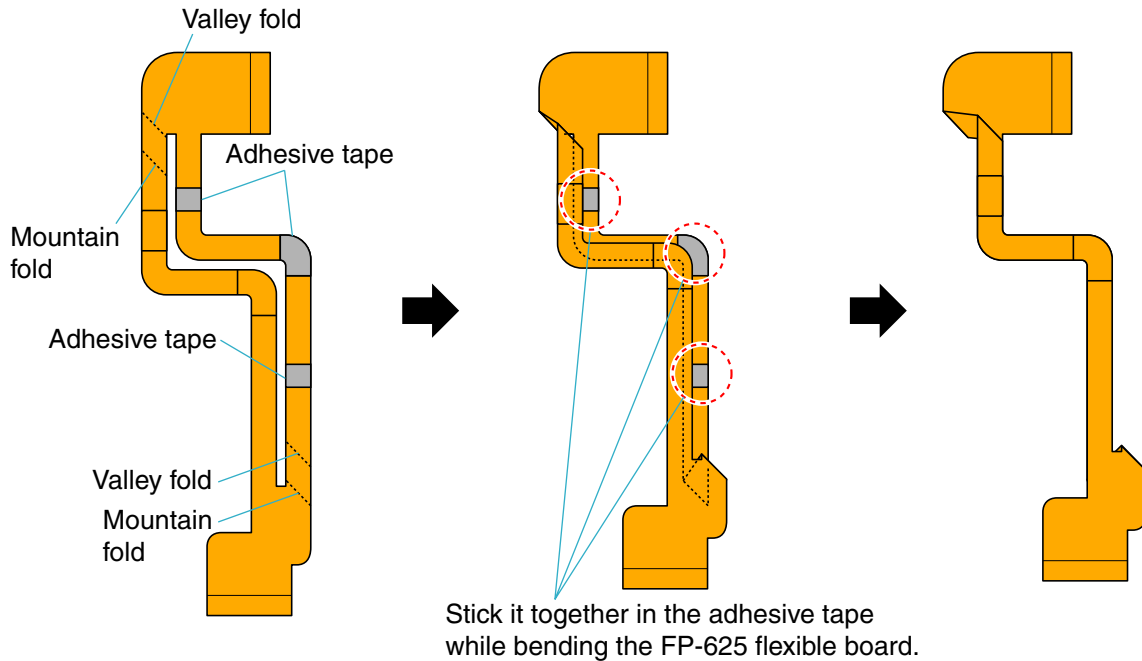

- ② Put the FP-625 flexible board on the hinge cover (M).

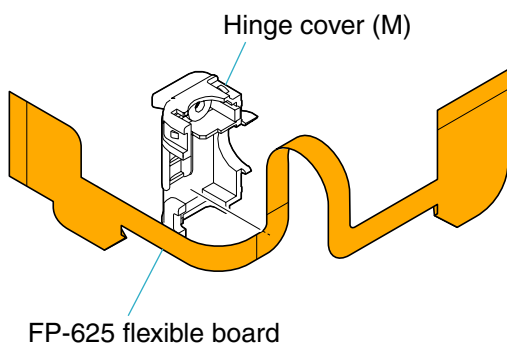

- ③ Fix hinge cover (M) and the panel hinge assy (M) with the screw.

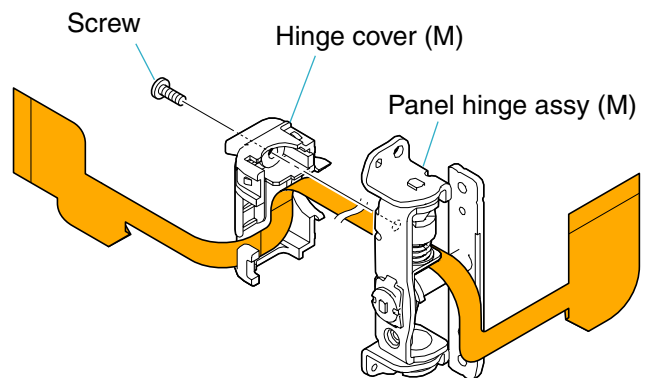

- ④ Install the hinge cover (C) in the hinge cover (M).

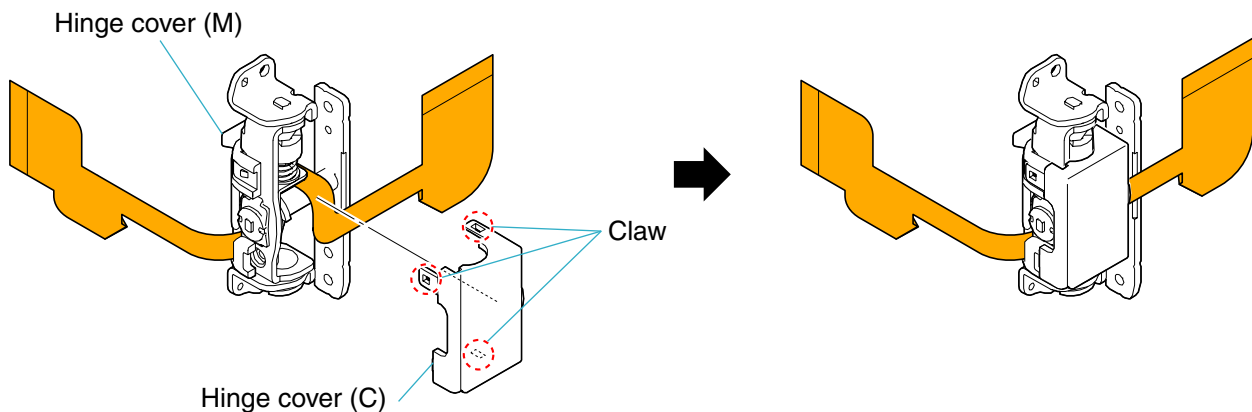

### 3. DIAGRAMAS EM BLOCOS

#### Link

<a href="#">• DIAGRAMA EM BLOCO GERAL (1/5)</a>	<a href="#">• DIAGRAMA EM BLOCO GERAL (5/5)</a>
<a href="#">• DIAGRAMA EM BLOCO GERAL (2/5)</a>	<a href="#">• DIAGRAMA EM BLOCO POWER (1/3)</a>
<a href="#">• DIAGRAMA EM BLOCO GERAL (3/5)</a>	<a href="#">• DIAGRAMA EM BLOCO POWER (2/3)</a>
<a href="#">• DIAGRAMA EM BLOCO GERAL (4/5)</a>	<a href="#">• DIAGRAMA EM BLOCO POWER (3/3)</a>



### 3. DIAGRAMAS EM BLOCOS

3-1. DIAGRAMA EM BLOCO GERAL (1/5) ( ) : Number in parenthesis ( ) indicates the division number of schematic diagram where the component is located.

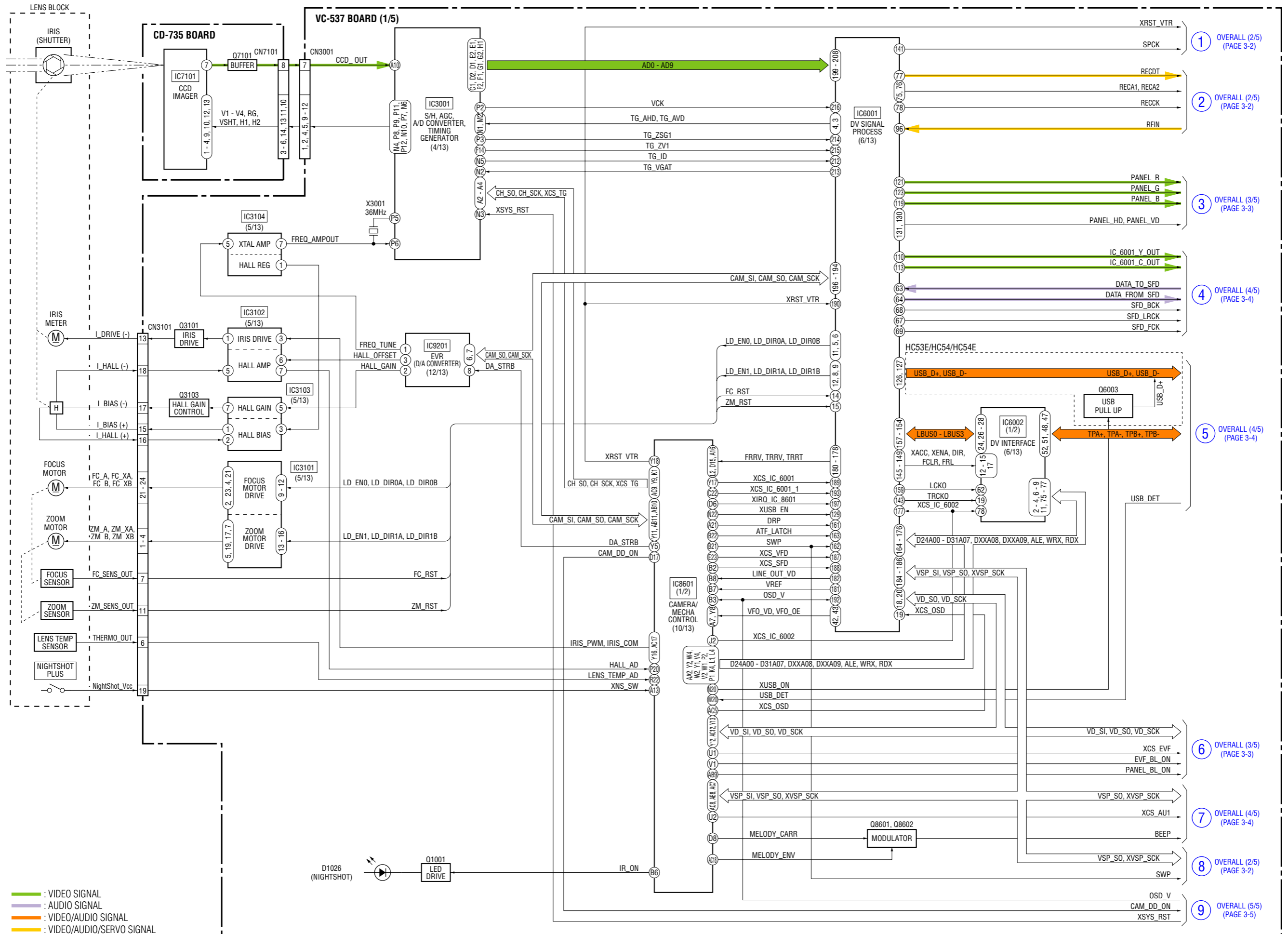

3-2. DIAGRAMA EM BLOCO GERAL (2/5) ( ) : Number in parenthesis ( ) indicates the division number of schematic diagram where the component is located.

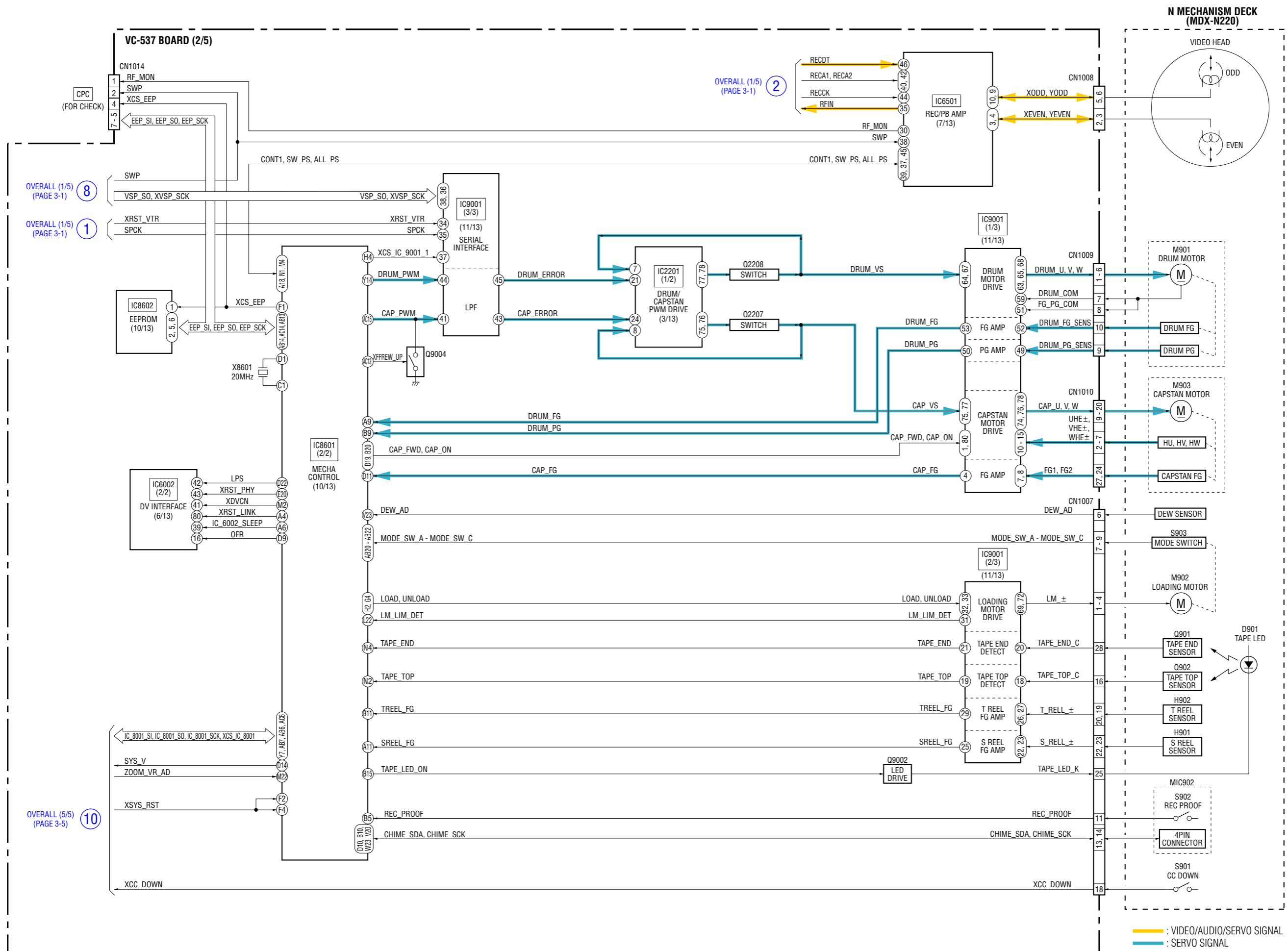

3-3. DIAGRAMA EM BLOCO GERAL (3/5) ( ) : Number in parenthesis ( ) indicates the division number of schematic diagram where the component is located.

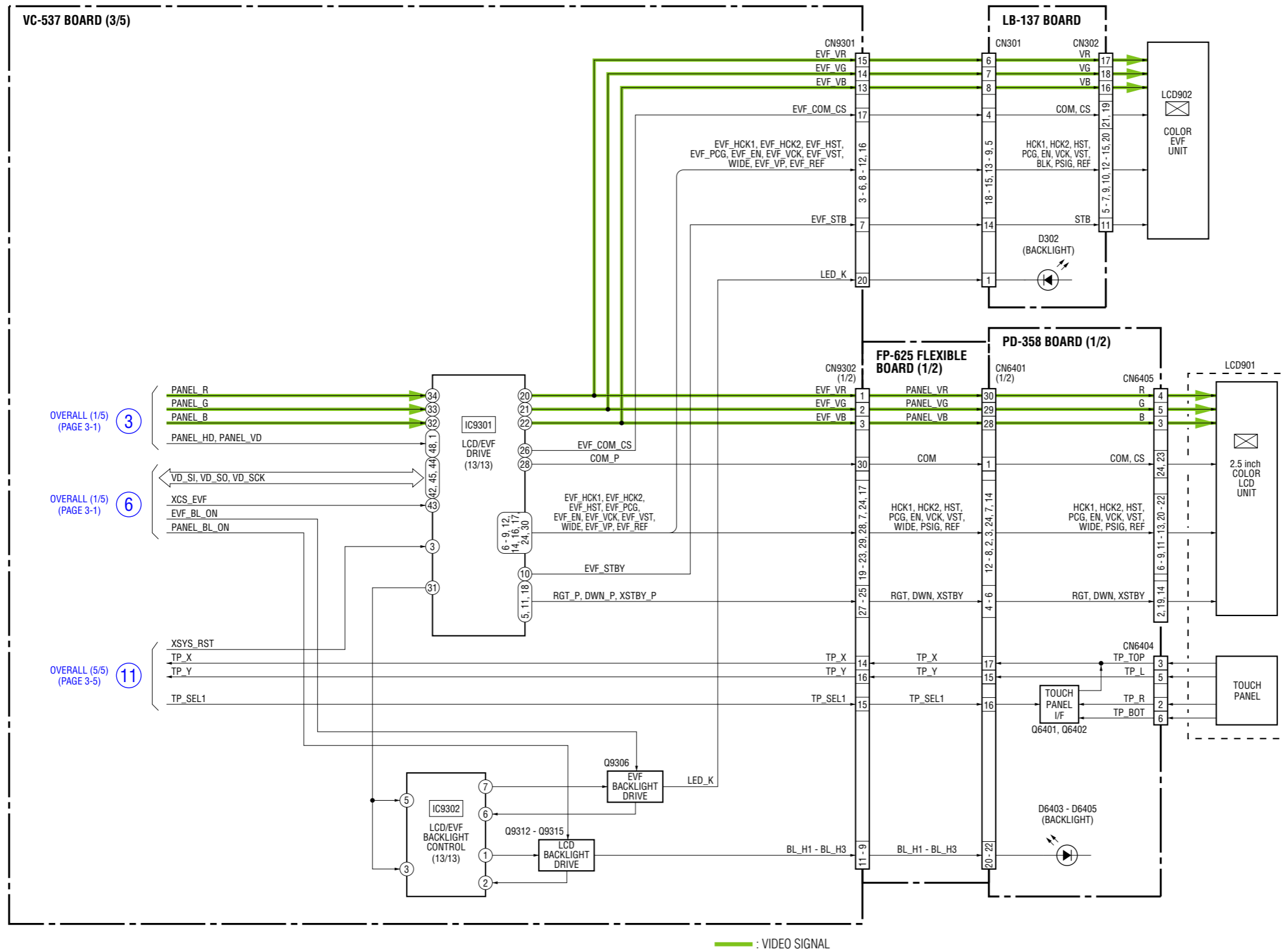

3-4. DIAGRAMA EM BLOCO GERAL (4/5) ( ) : Number in parenthesis ( ) indicates the division number of schematic diagram where the component is located.

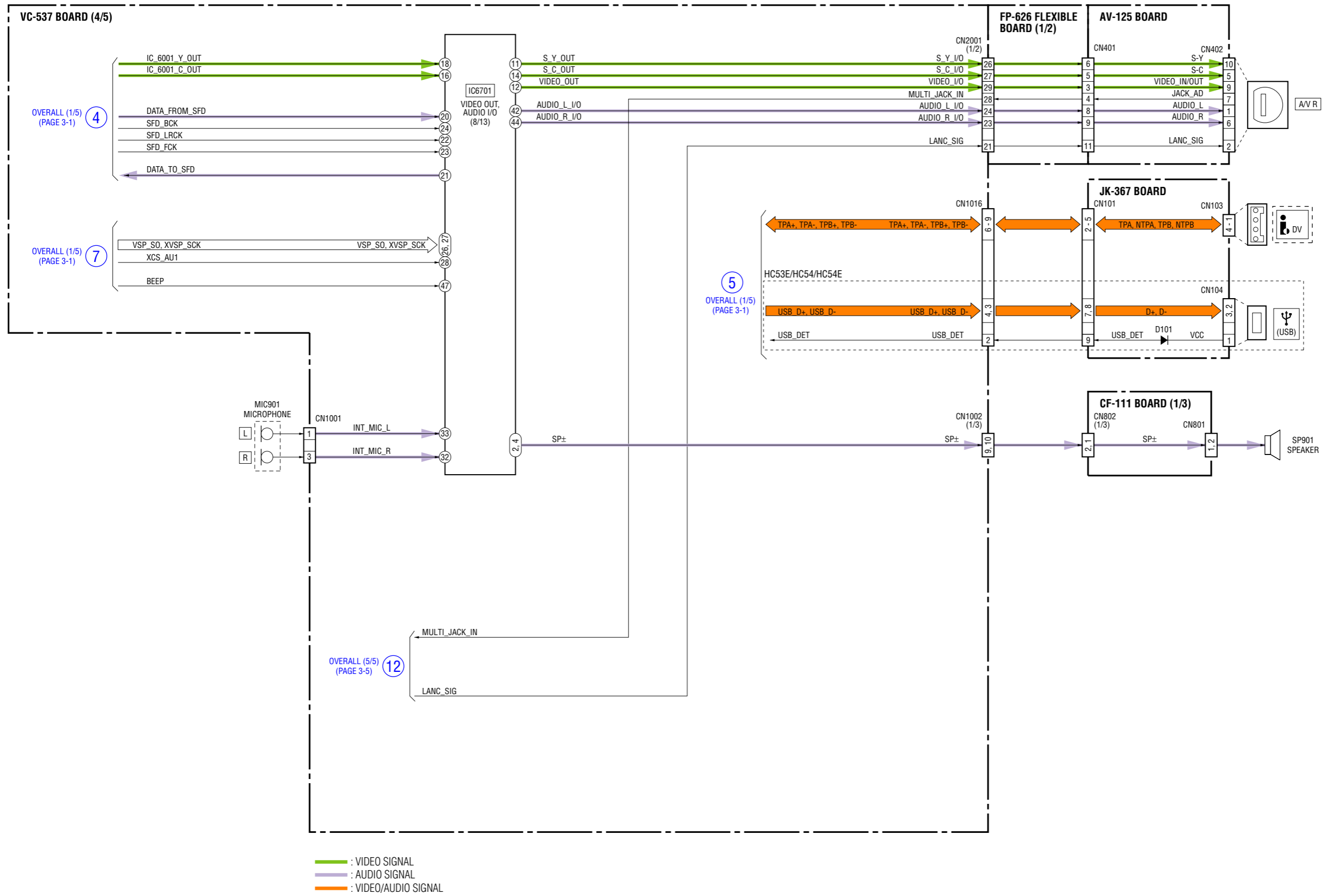

3-5. DIAGRAMA EM BLOCO GERAL (5/5) ( ) : Number in parenthesis ( ) indicates the division number of schematic diagram where the component is located.

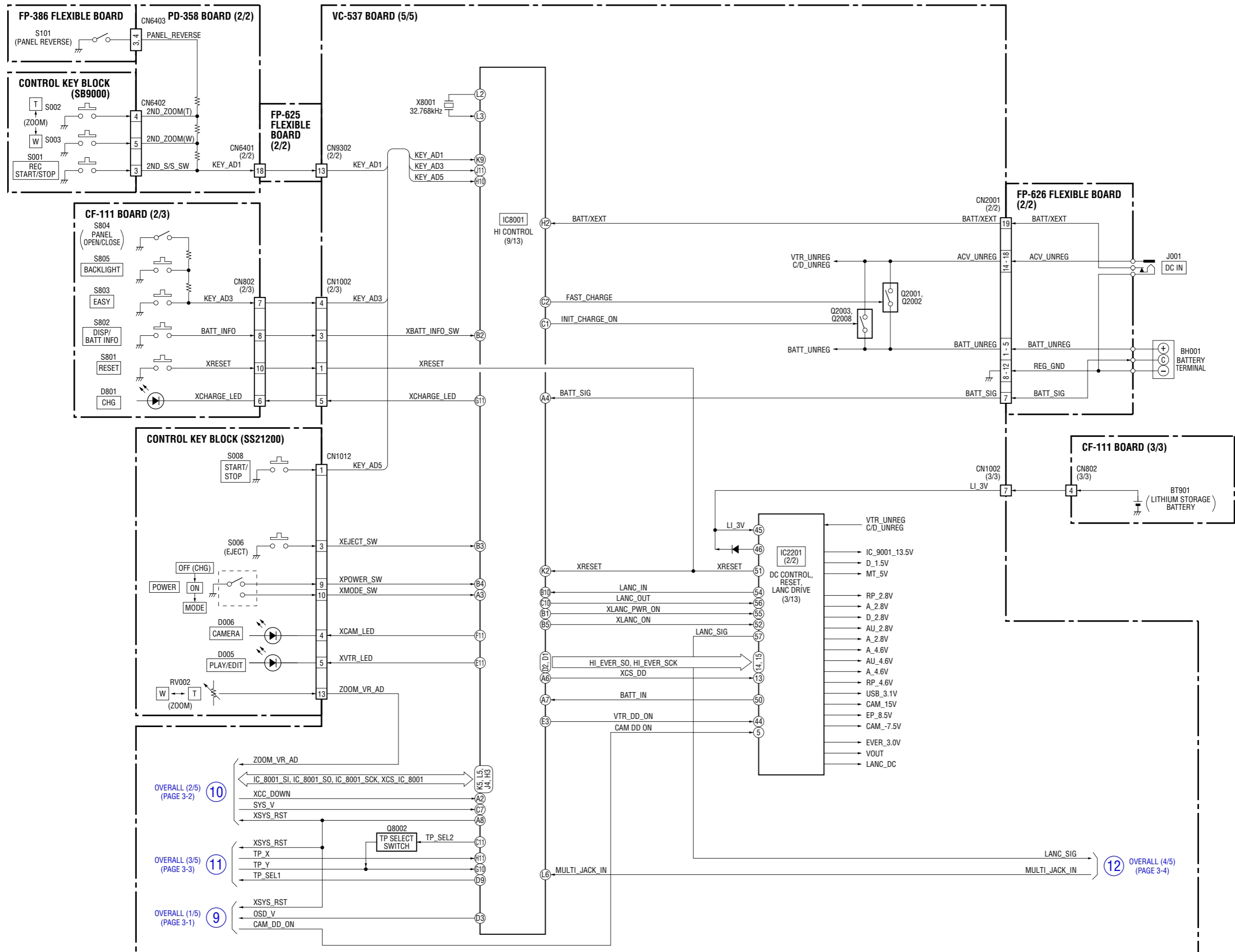

3-6. DIAGRAMA EM BLOCO POWER (1/3) ( ) : Number in parenthesis ( ) indicates the division number of schematic diagram where the component is located.

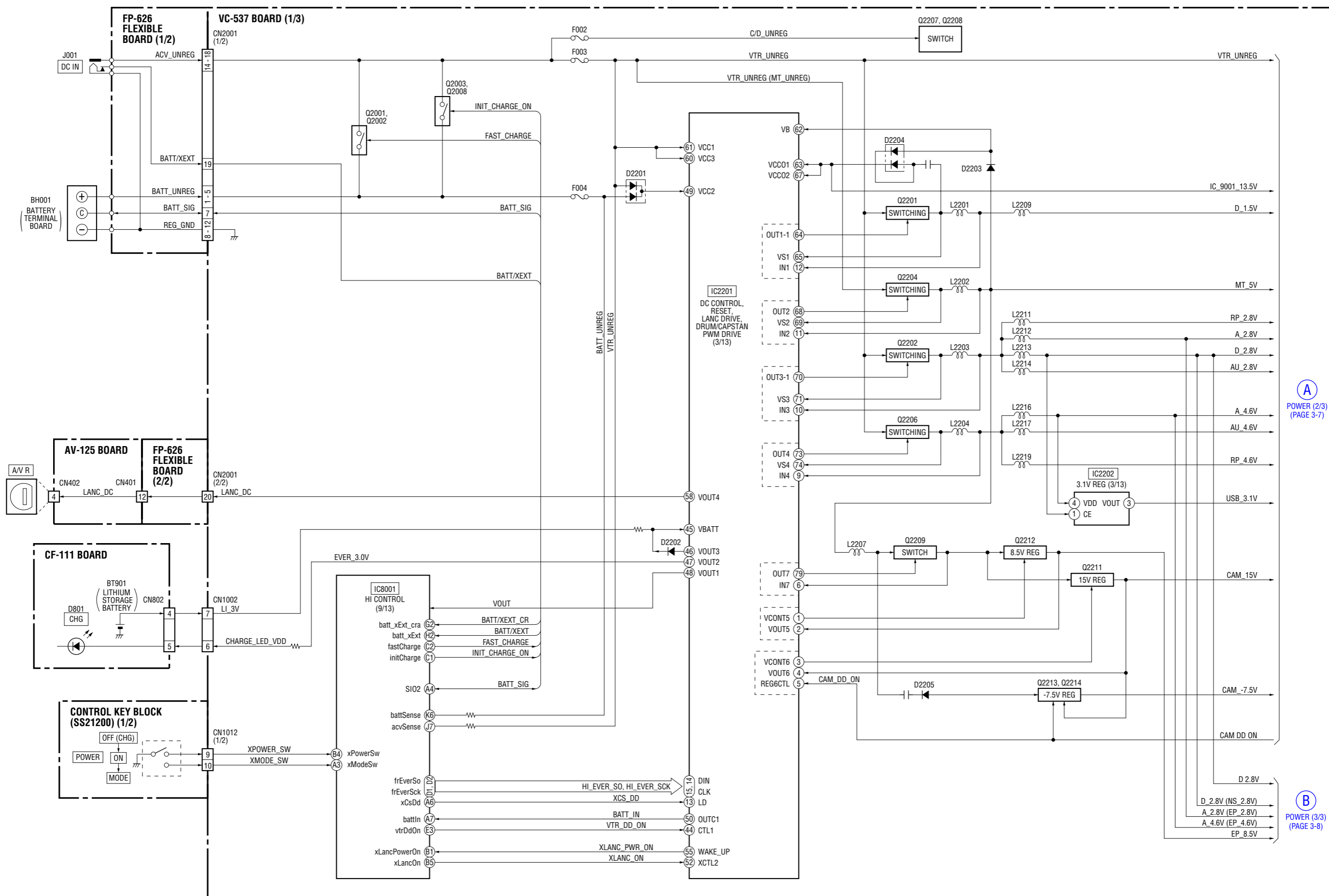

A  
POWER (2/3)  
(PAGE 3-7)

B  
POWER (3/3)  
(PAGE 3-8)

3-7. DIAGRAMA EM BLOCO POWER (2/3) ( ) : Number in parenthesis ( ) indicates the division number of schematic diagram where the component is located.

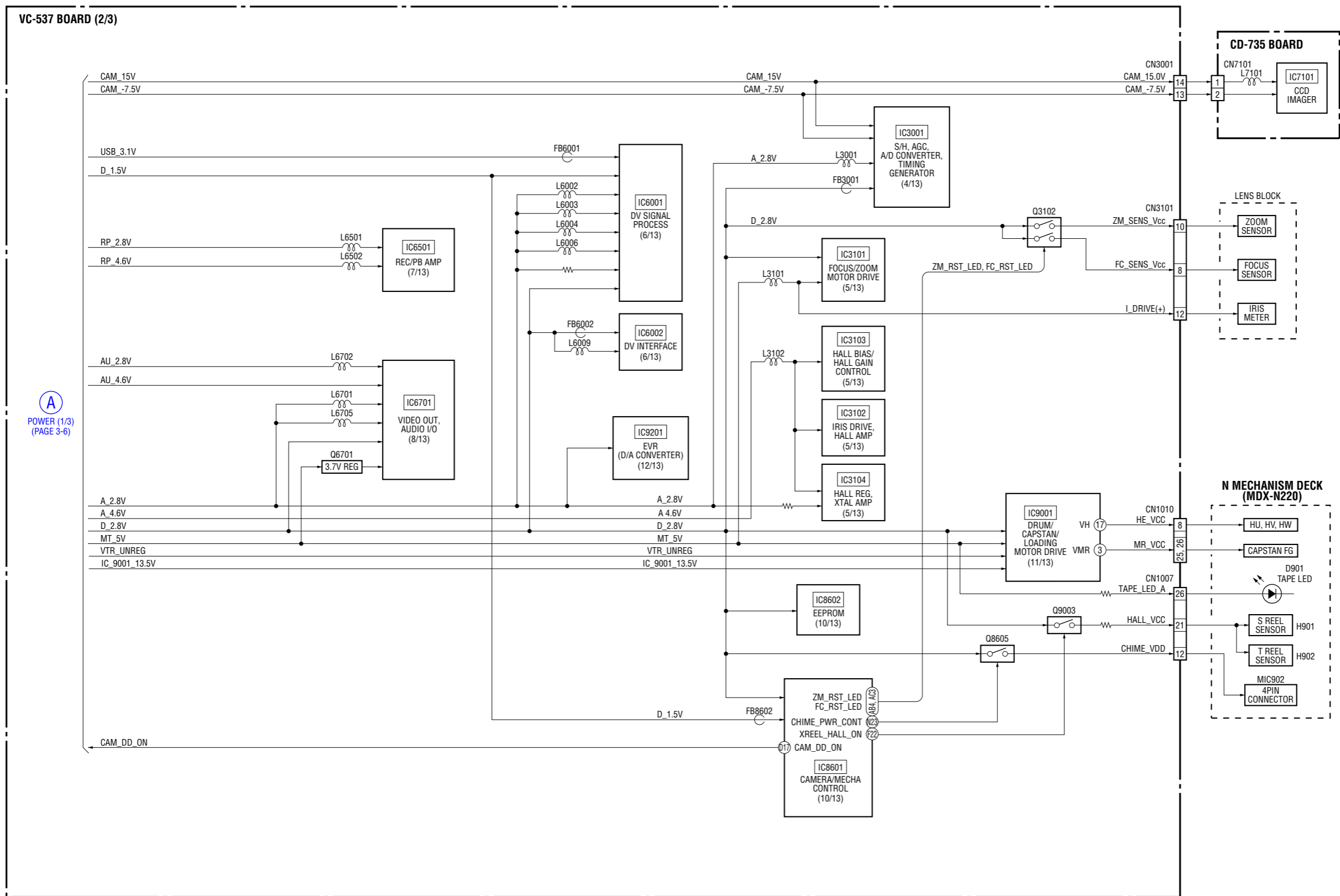

3-8. DIAGRAMA EM BLOCO POWER (3/3) ( ) : Number in parenthesis ( ) indicates the division number of schematic diagram where the component is located.

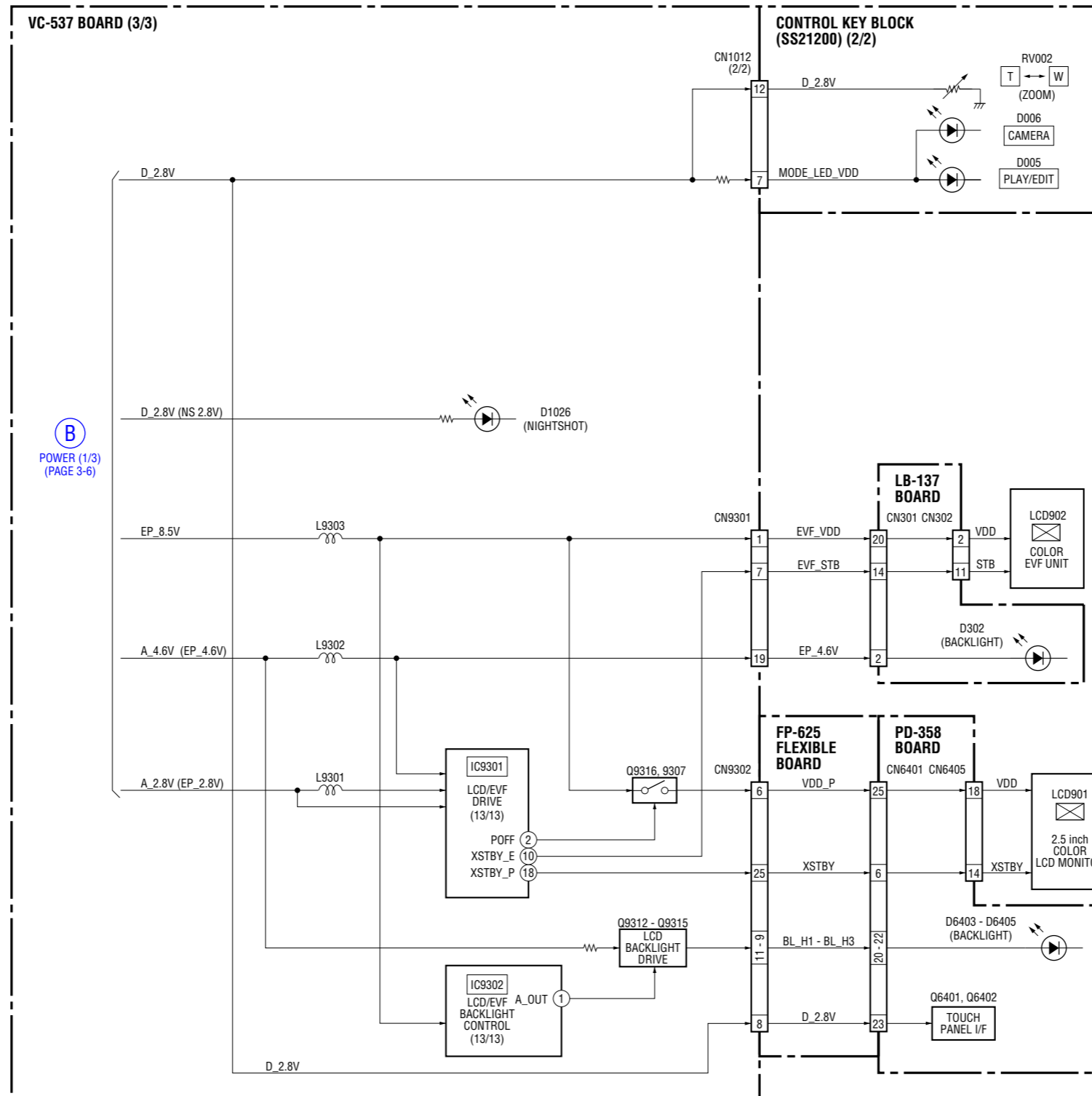



# 4. PLACAS DE CIRCUITO IMPRESSO E DIAGRAMAS ESQUEMÁTICOS

## 4-1. DIAGRAMAS ESQUEMÁTICOS DA ESTRUTURA

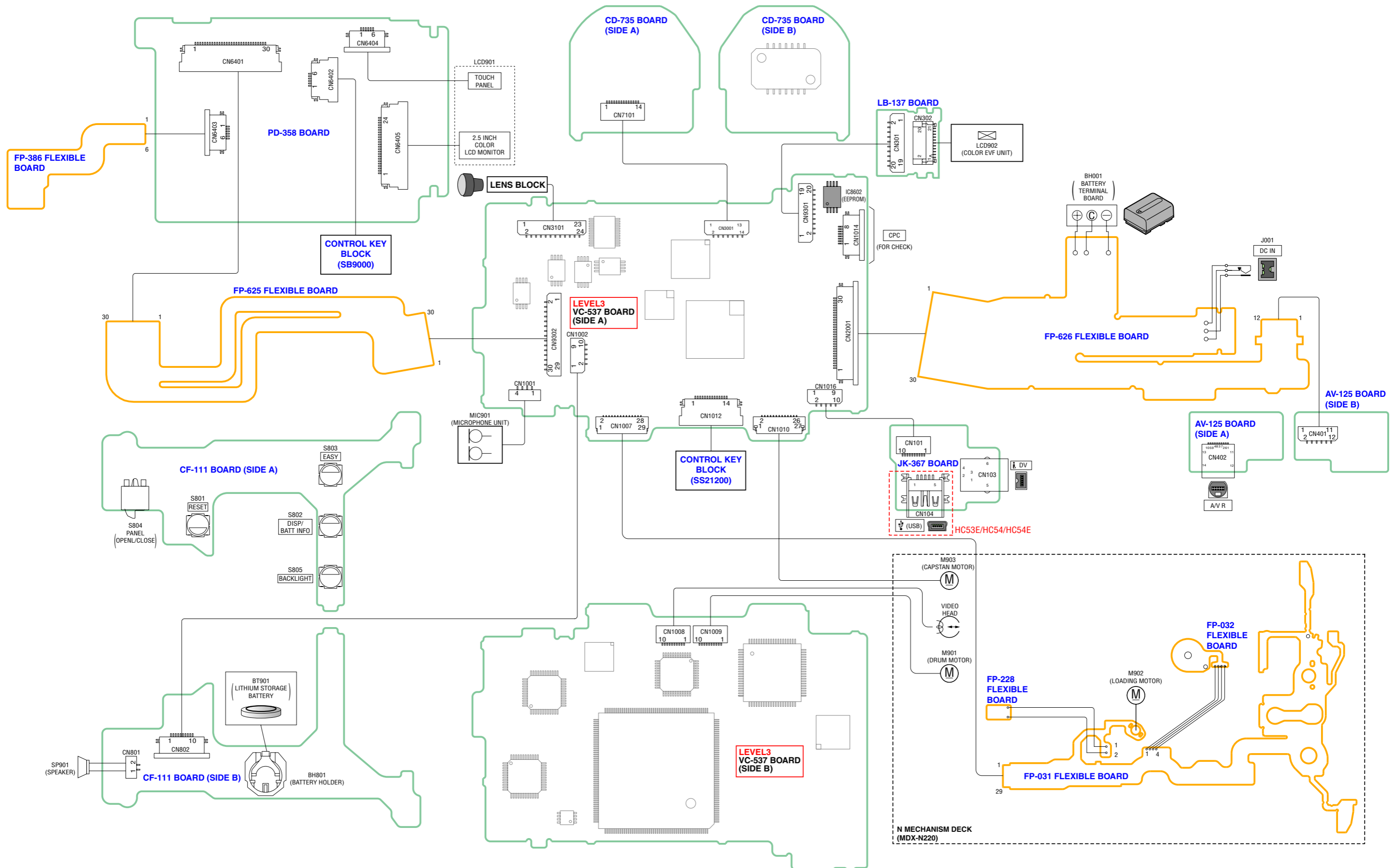

## 4-2. DIAGRAMAS ESQUEMÁTICOS

### Link

• PLACA CD-735 (CCD IMAGER)	• PLACA FLEXIVEL FP-386 <b>(PANEL REVERSE DETECT)</b>
• PLACA PD-358 (LCD, LCD BACKLIGHT)	• PLACA FLEXIVEL FP-625 <b>(VC-PD CONNECTION)</b>
• PLACA AV-125 (AV CONNECTOR)	• PLACA FLEXIVEL FP-626 <b>(DC IN)</b>
• PLACA CF-111 (CONTROL SWITCH)	• BLOCO DA CHAVE DE CONTROLE (SB9000)
• PLACA JK-367 (DV/USB CONNECTOR)	• BLOCO DA CHAVE DE CONTROLE (SS21200)
• PLACA LB-137 (EVF)	• PLACA FLEXIVEL FP-031, FP-032, FP-228

• NOTA COMUM PARA DIAGRAMAS ESQUEMÁTICOS

### 4-2. DIAGRAMAS ESQUEMÁTICOS

**THIS NOTE IS COMMON FOR SCHEMATIC DIAGRAMS**  
**(In addition to this, the necessary note is printed in each block)**

**(For schematic diagrams)**

- All capacitors are in  $\mu\text{F}$  unless otherwise noted.  $\text{pF} : \mu\text{F}$ . 50 V or less are not indicated except for electrolytics and tantalums.
- Chip resistors are 1/10 W unless otherwise noted.  $\text{k}\Omega=1000 \Omega$ ,  $\text{M}\Omega=1000 \text{k}\Omega$ .
- Caution when replacing chip parts.  
New parts must be attached after removal of chip.  
Be careful not to heat the minus side of tantalum capacitor, Because it is damaged by the heat.
- Some chip part will be indicated as follows.

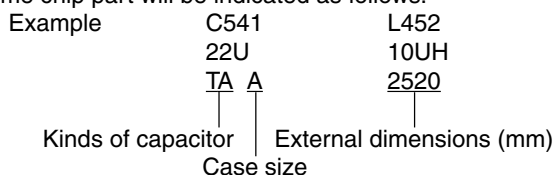

- Constants of resistors, capacitors, ICs and etc with XX indicate that they are not used.  
In such cases, the unused circuits may be indicated.
- Parts with ★ differ according to the model/destination. Refer to the mount table for each function.
- All variable and adjustable resistors have characteristic curve B, unless otherwise noted.
- Signal name  
XEDIT → EDIT PB/XREC → PB/REC
- : non flammable resistor
- : fusible resistor
- : panel designation
- : B+ Line
- : B- Line
- : IN/OUT direction of (+,-) B LINE.
- : adjustment for repair.
- : not use circuit

**(Measuring conditions voltage and waveform)**

- Voltages and waveforms are measured between the measurement points and ground when camera shoots color bar chart of pattern box. They are reference values and reference waveforms.  
(VOM of DC 10  $\text{M}\Omega$  input impedance is used)
- Voltage values change depending upon input impedance of VOM used.)

**Precautions for Replacement of Imager**

- If the imager has been replaced, carry out all the adjustments for the camera section.
- As the imager may be damaged by static electricity from its structure, handle it carefully like for the MOS IC.  
In addition, ensure that the receiver is not covered with dusts nor exposed to strong light.

1. Connection

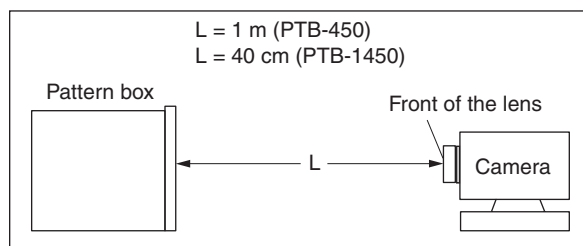
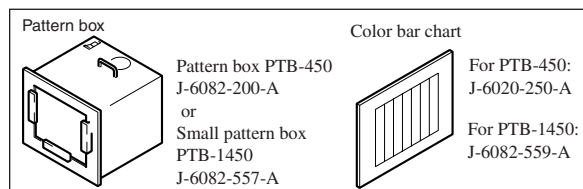

2. Adjust the distance so that the output waveform of Fig. a and the Fig. b can be obtain.

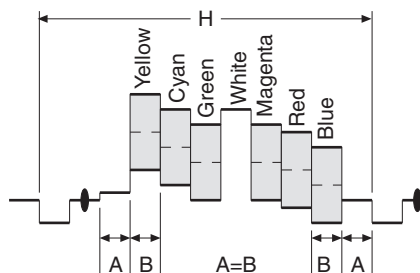

Fig. a (Video output terminal output waveform)

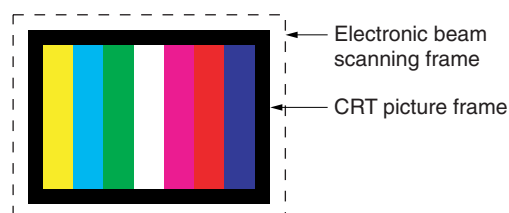

Fig.b (Picture on monitor TV)

When indicating parts by reference number, please include the board name.

The components identified by mark  $\triangle$  or dotted line with mark  $\triangle$  are critical for safety.  
Replace only with part number specified.

Les composants identifiés par une marque  $\triangle$  sont critiques pour la sécurité.  
Ne les remplacer que par une pièce portant le numéro spécifié.

1 2 3 4 5 6 7 8

A

A

B

B

C

C

D

D

E

E

F

F

08

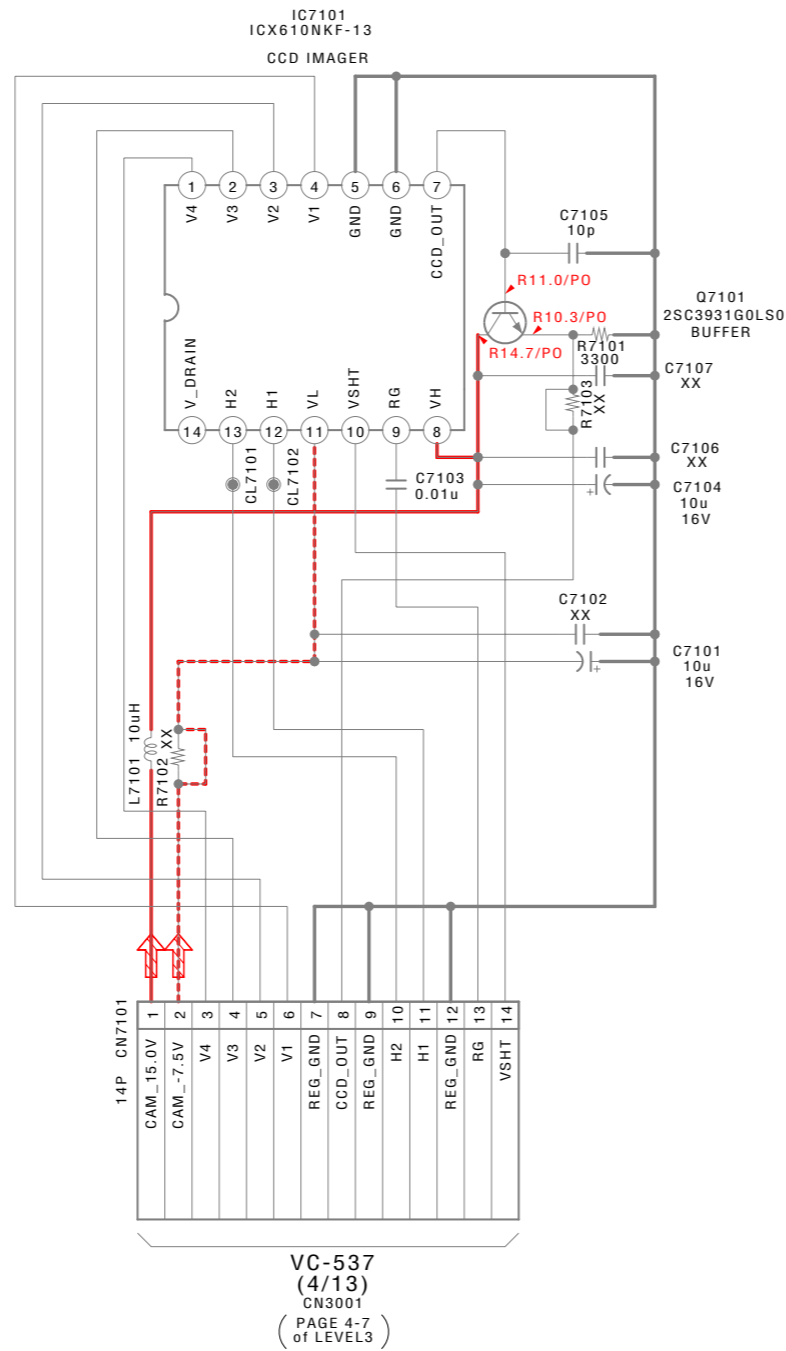

Note: IC7101 is not included in CD-735 complete board.  
 Note: Voltage of IC7101 can not be measured, because this is mounted by side of the lens.

# CD-735 BOARD

## CCD IMAGER

XX MARK:NO MOUNT  
 NO MARK:REC/PB MODE  
 R:REC MODE  
 P:PB MODE

Diagramas esquemático da placa VC-537 não são mostradas.  
Páginas a partir 4-4 a 4-16 não são mostradas.

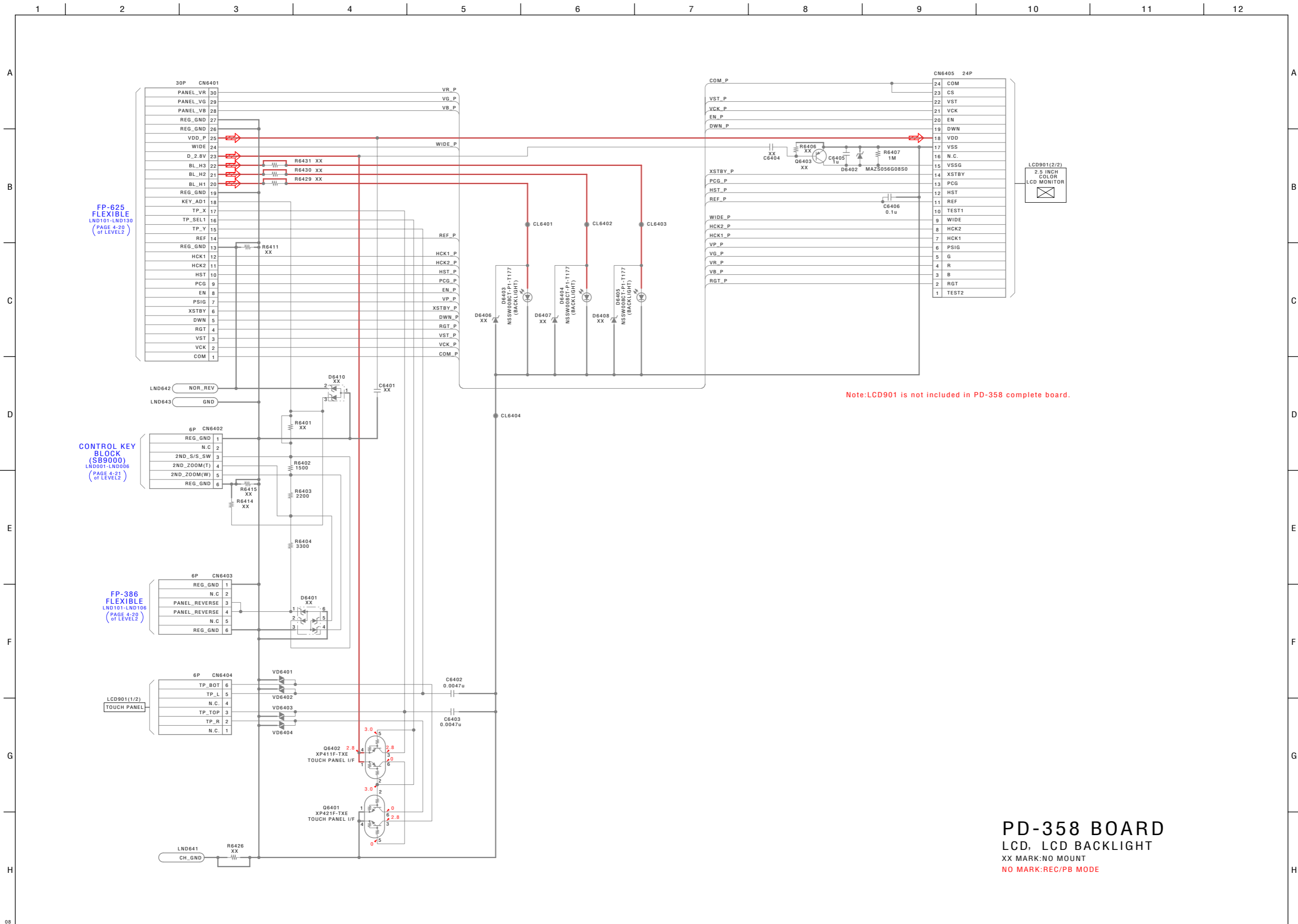

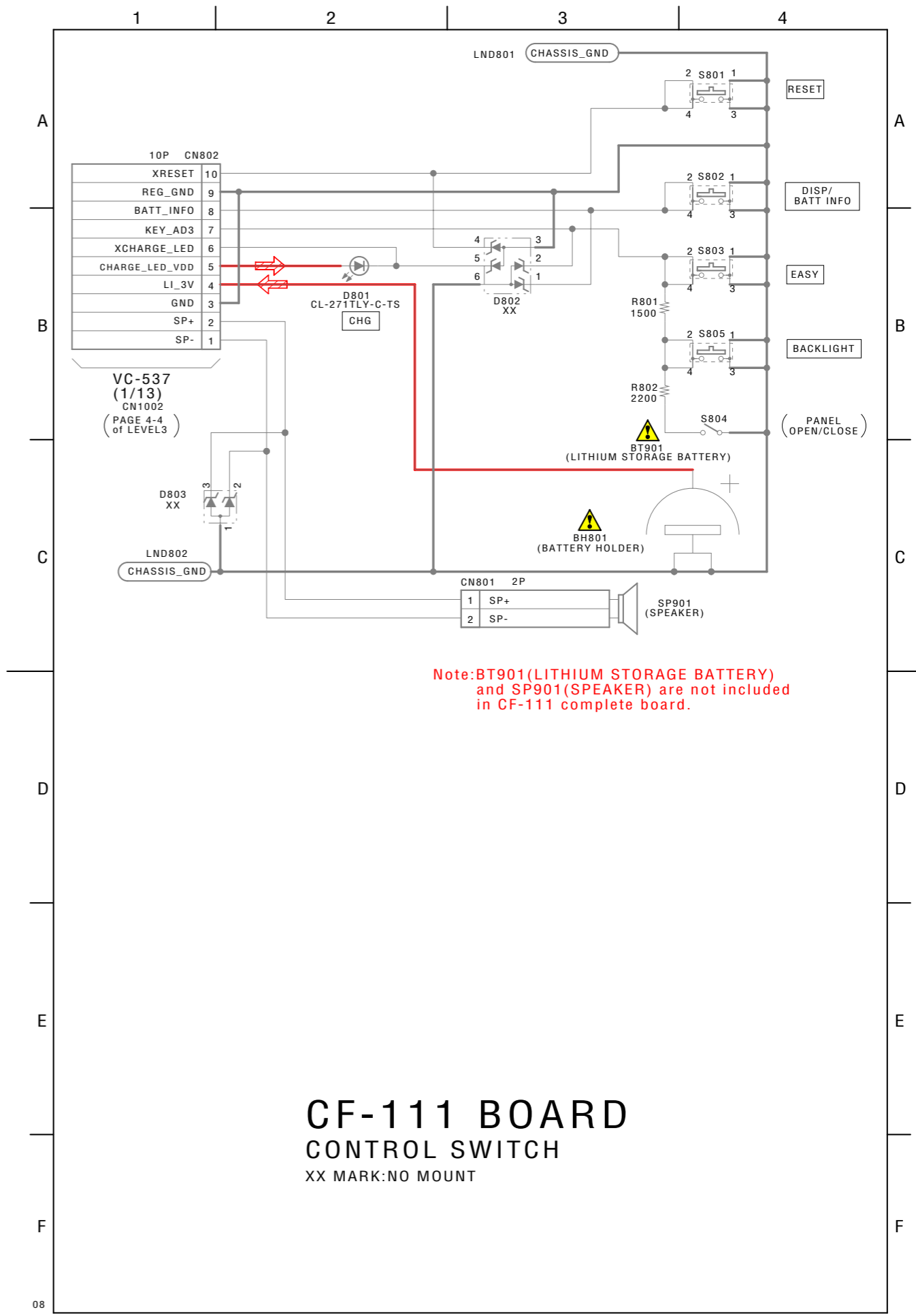
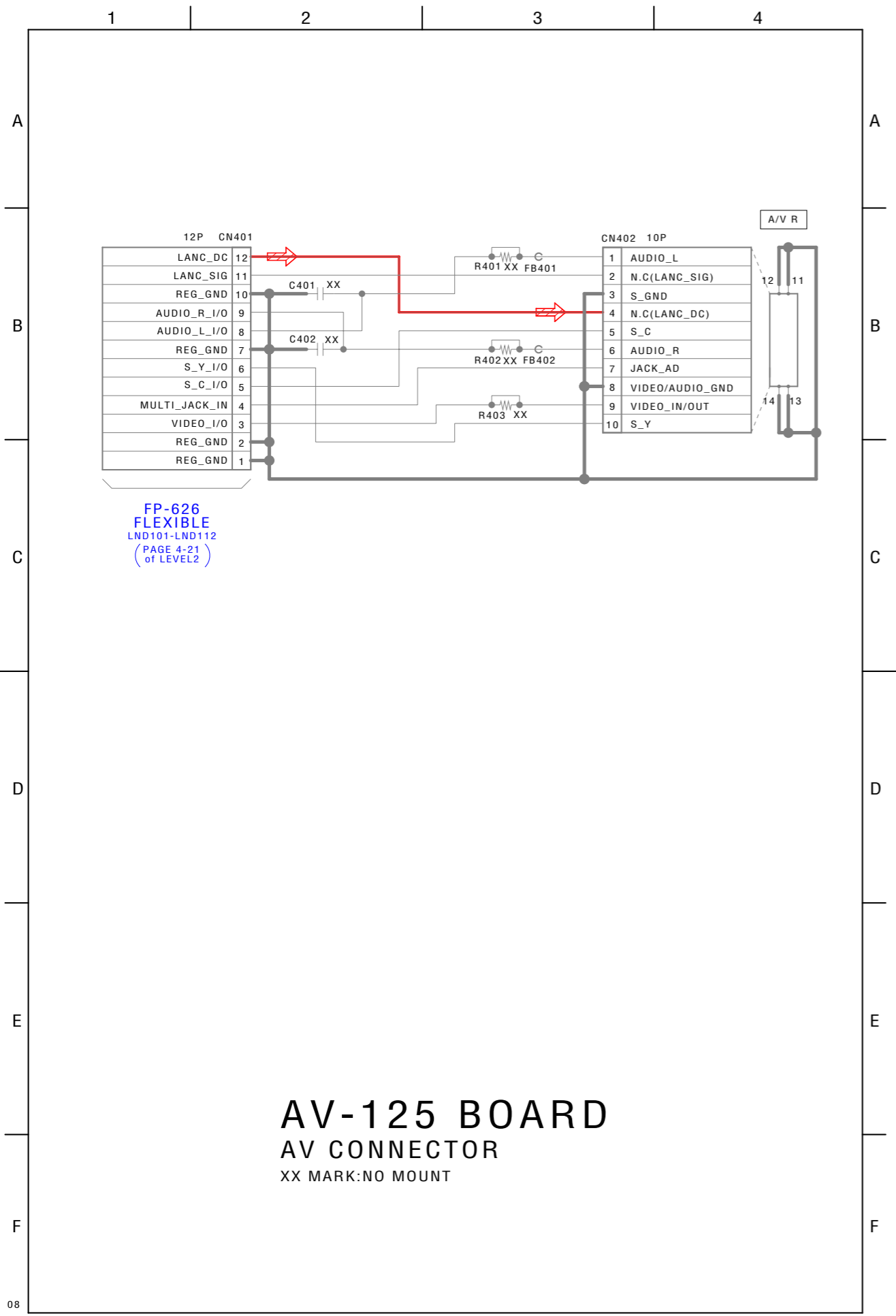

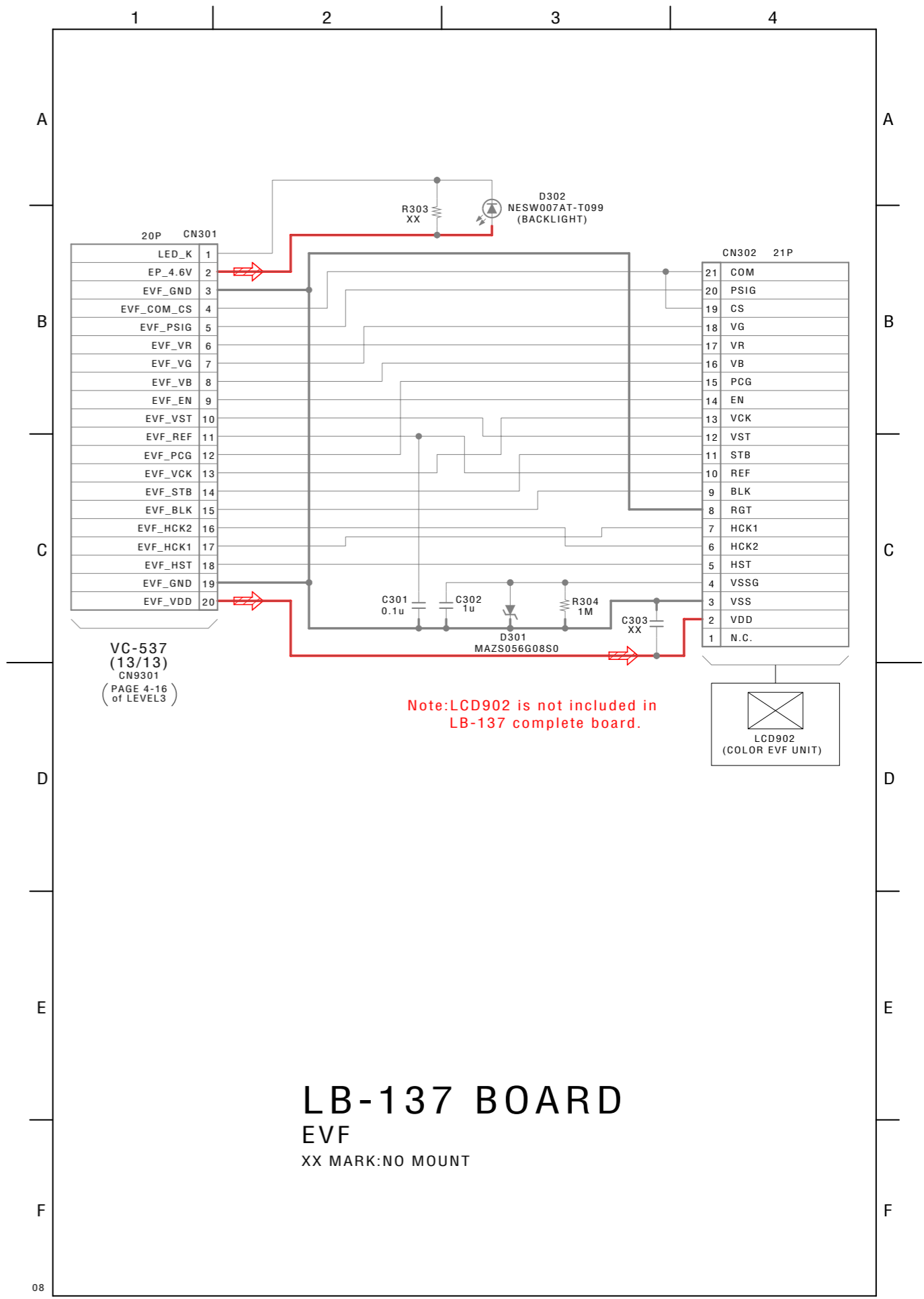
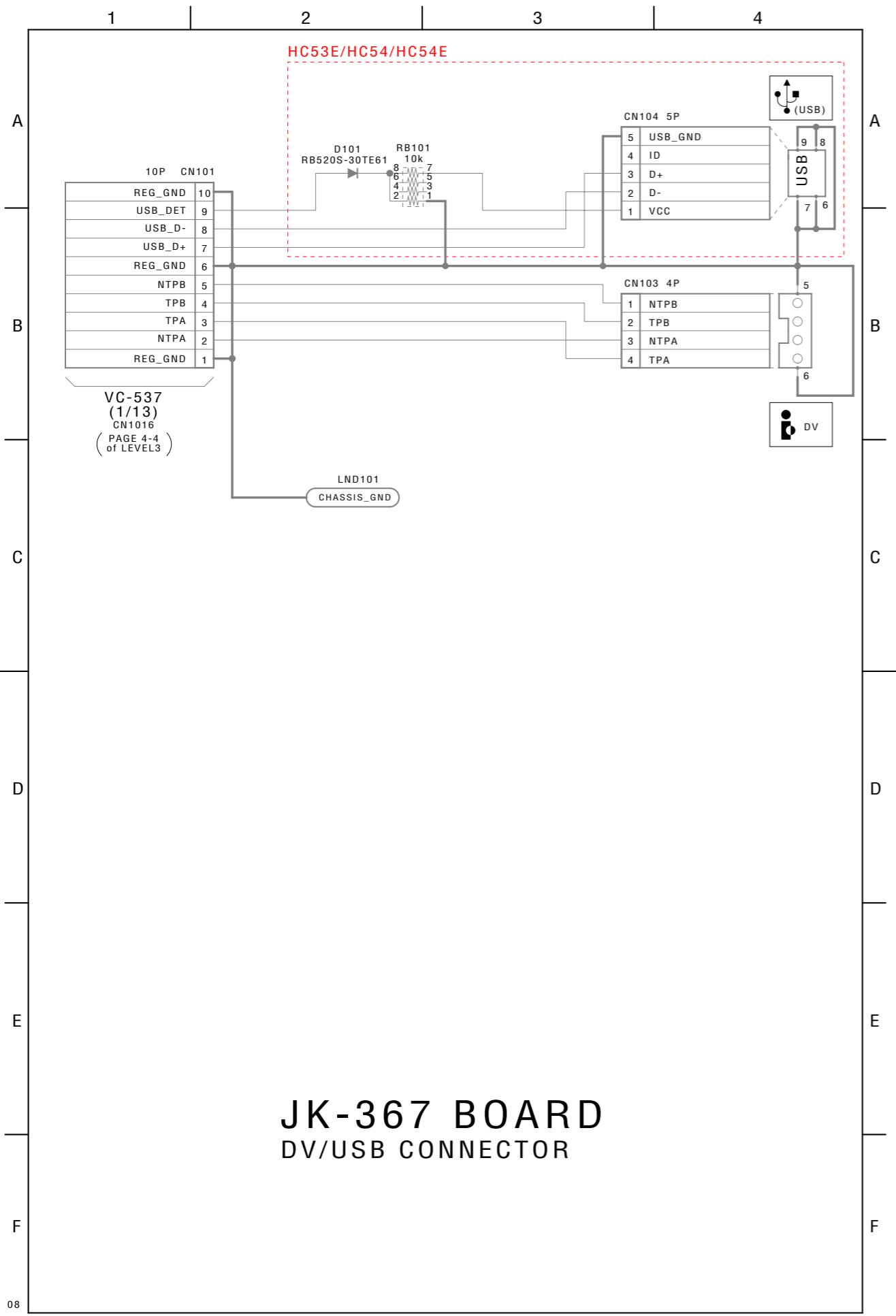



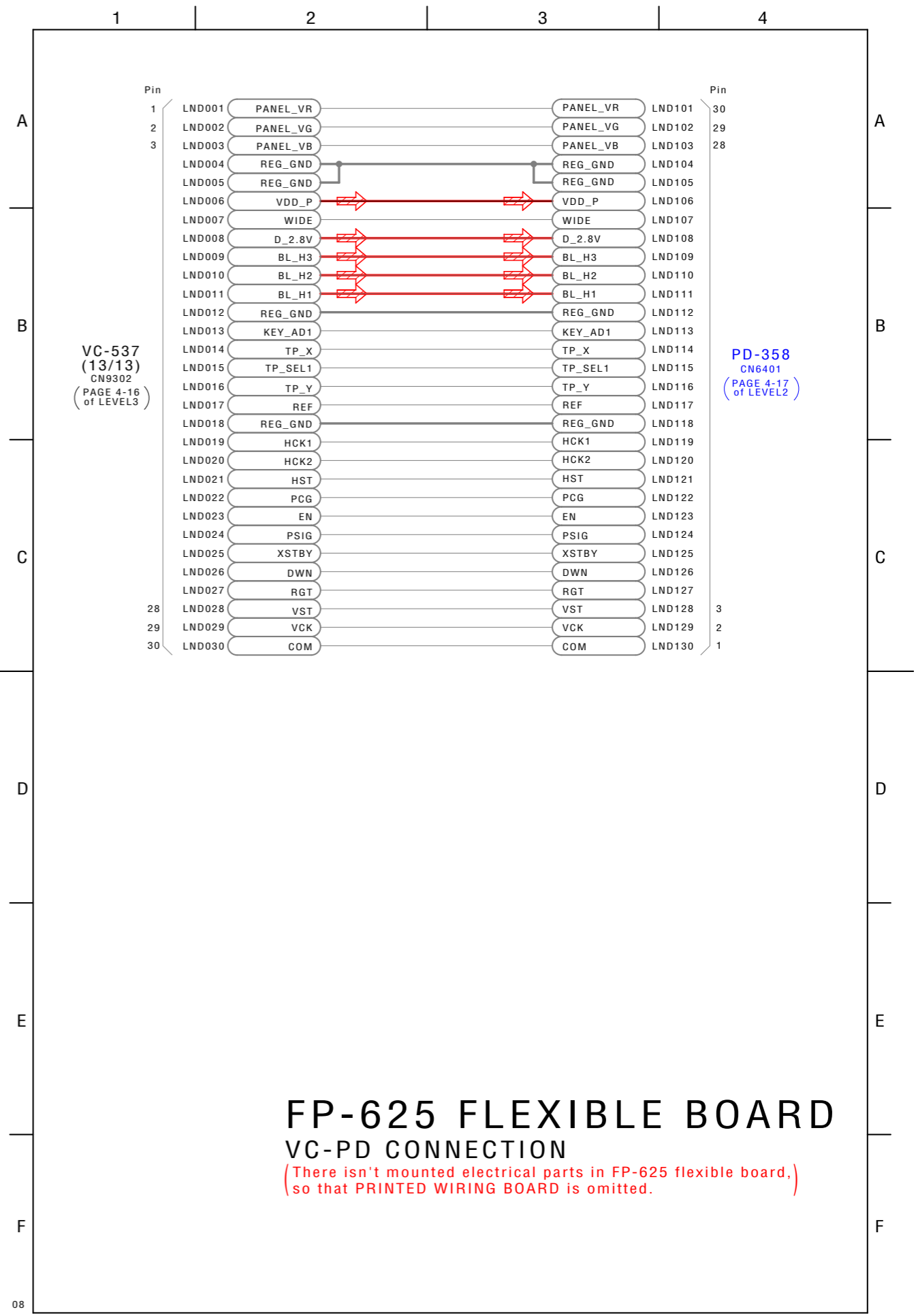
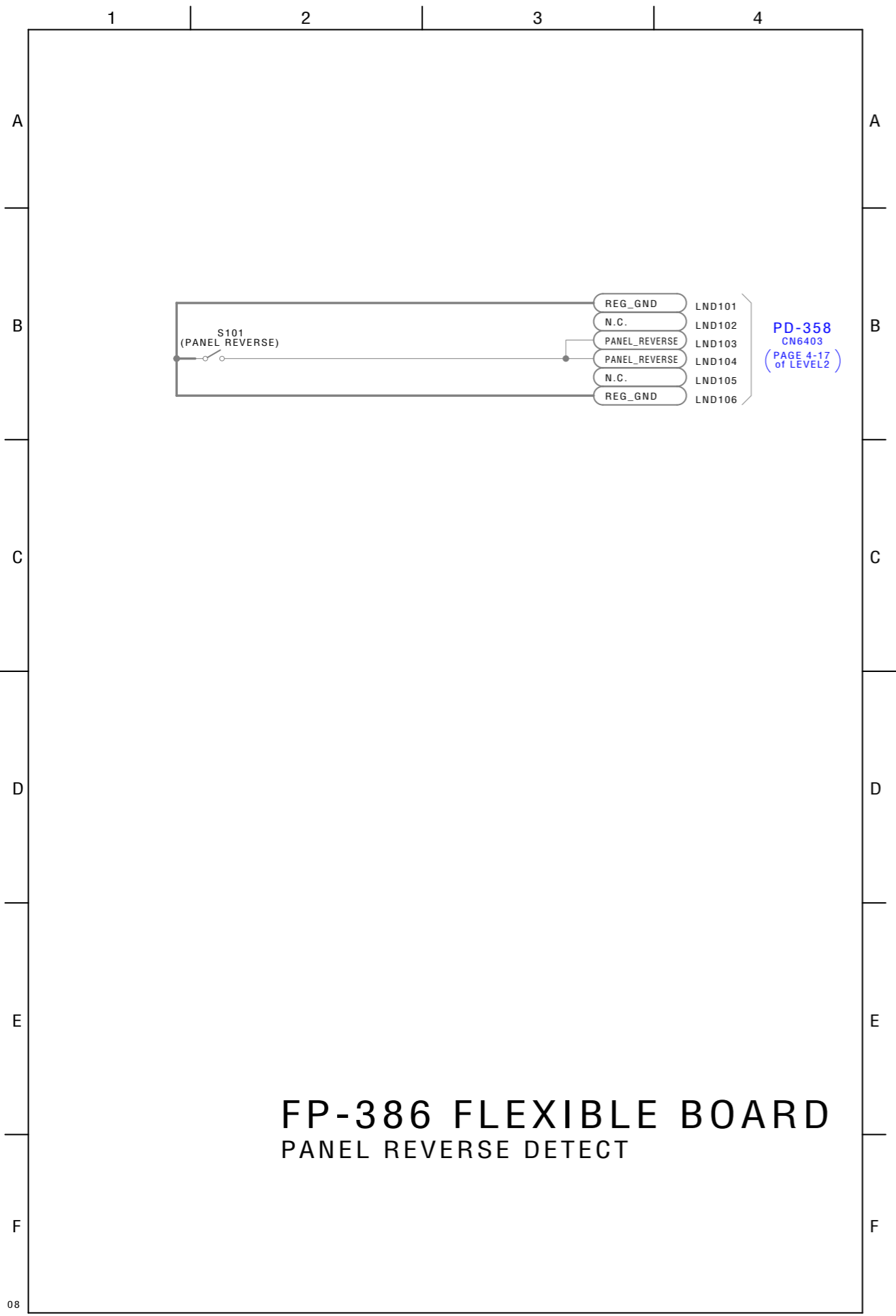

• Refer to page 4-2 for mark ▲.

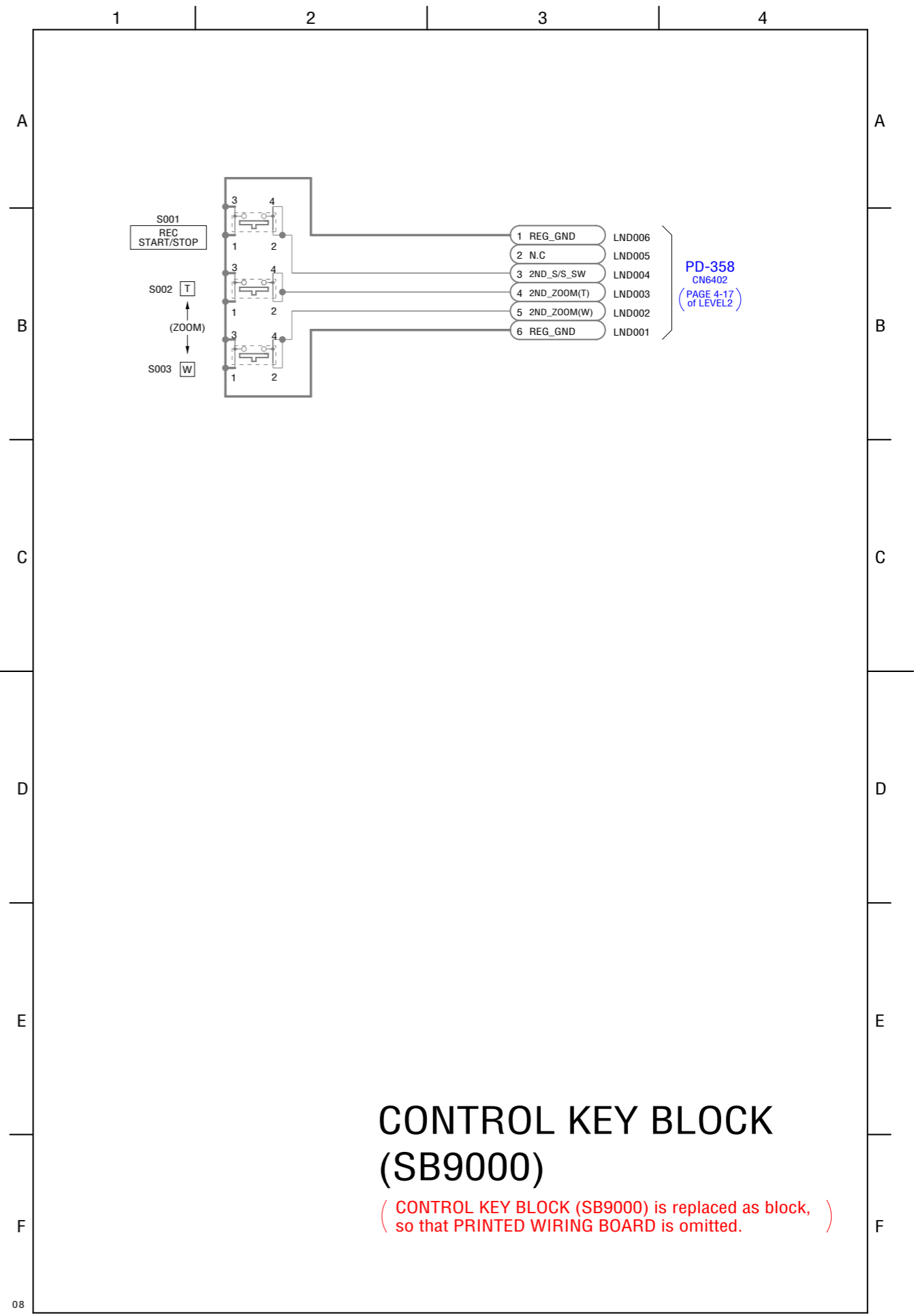
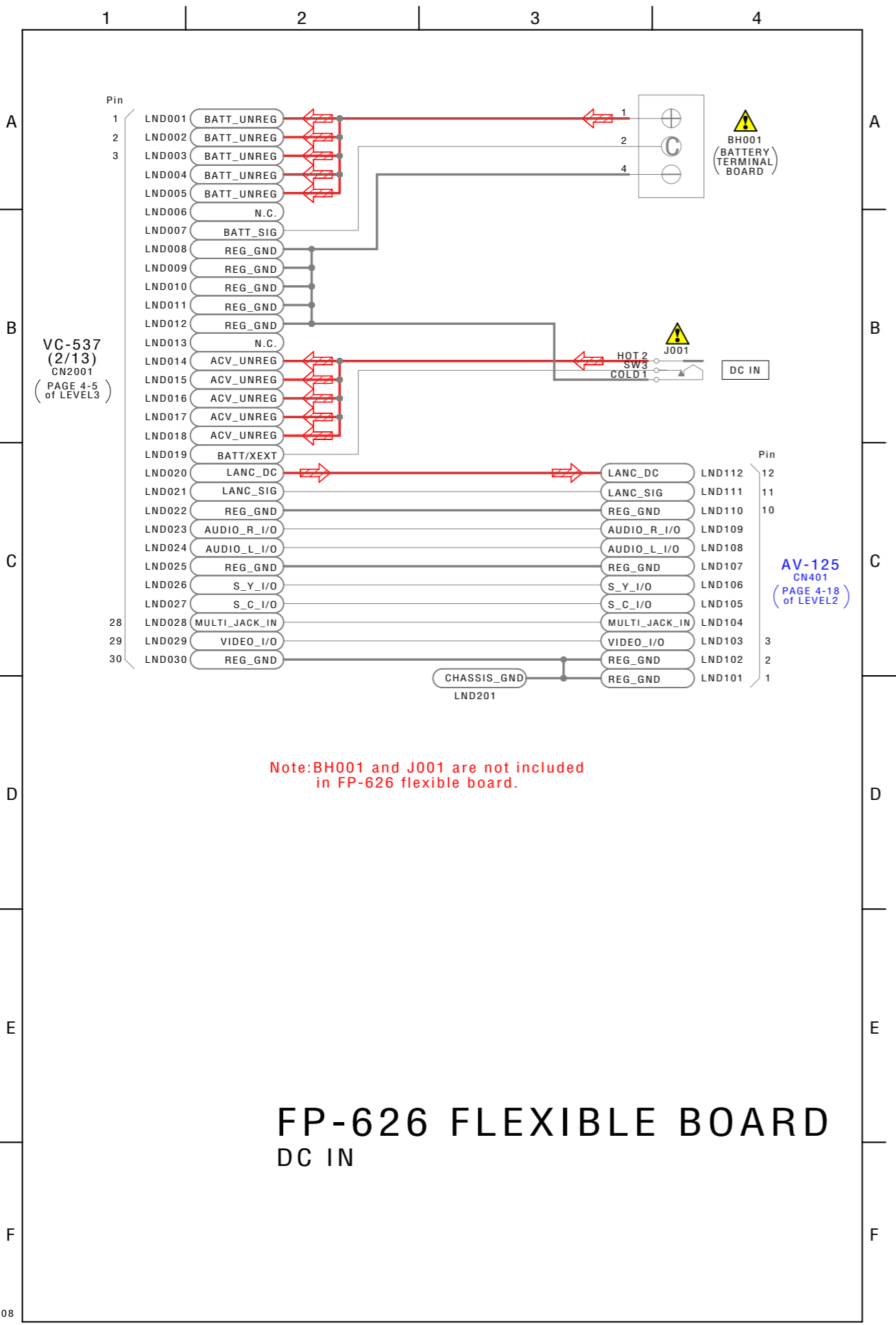

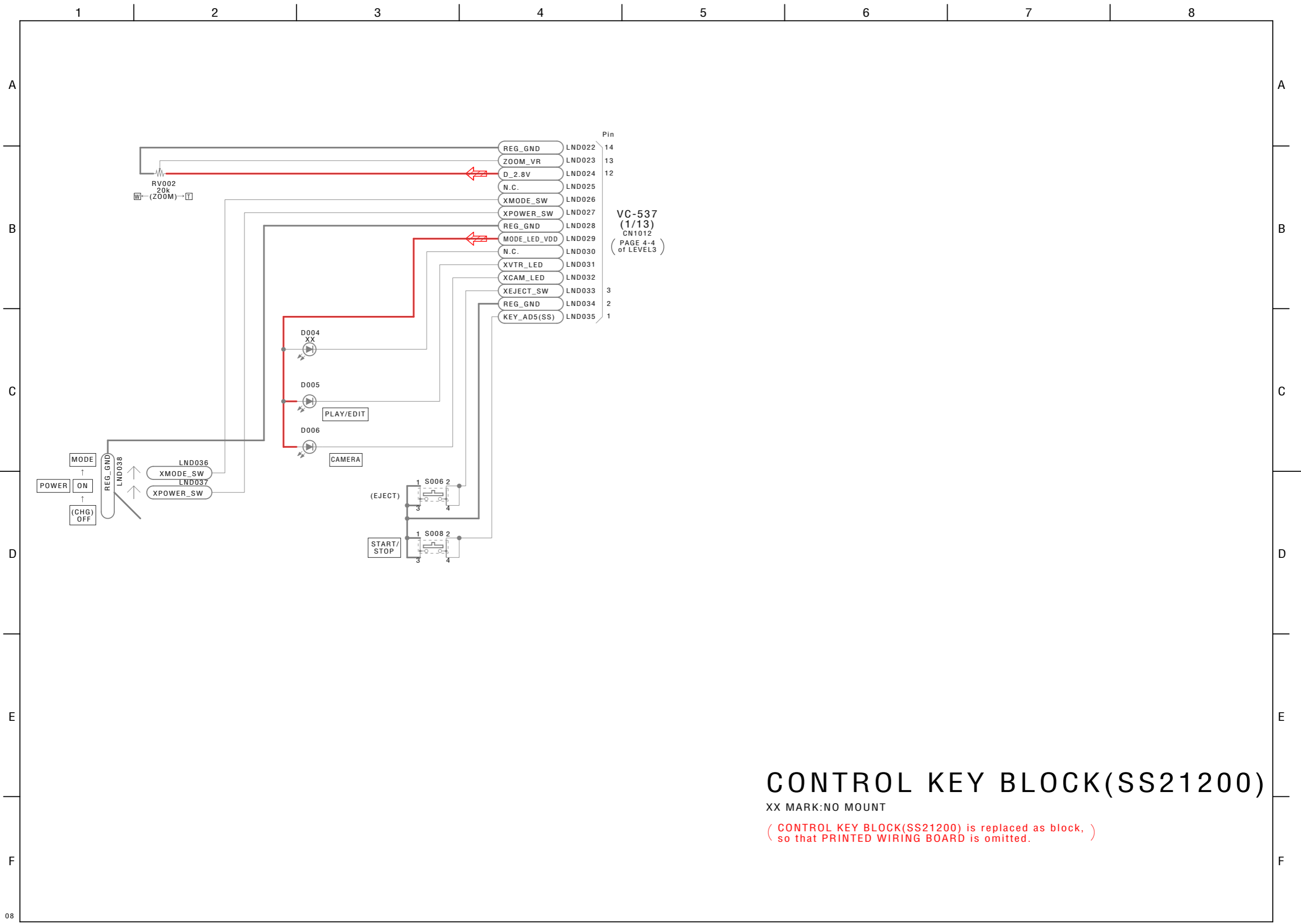

# CONTROL KEY BLOCK(SS21200)

XX MARK:NO MOUNT

( CONTROL KEY BLOCK(SS21200) is replaced as block, )  
 so that PRINTED WIRING BOARD is omitted.

1 2 3 4 5 6 7 8 9

A  
B  
C  
D  
E  
F

# MECHANISM BLOCK

VC-537  
(1/13)  
CN1007  
(PAGE 4-4  
of LEVEL3)

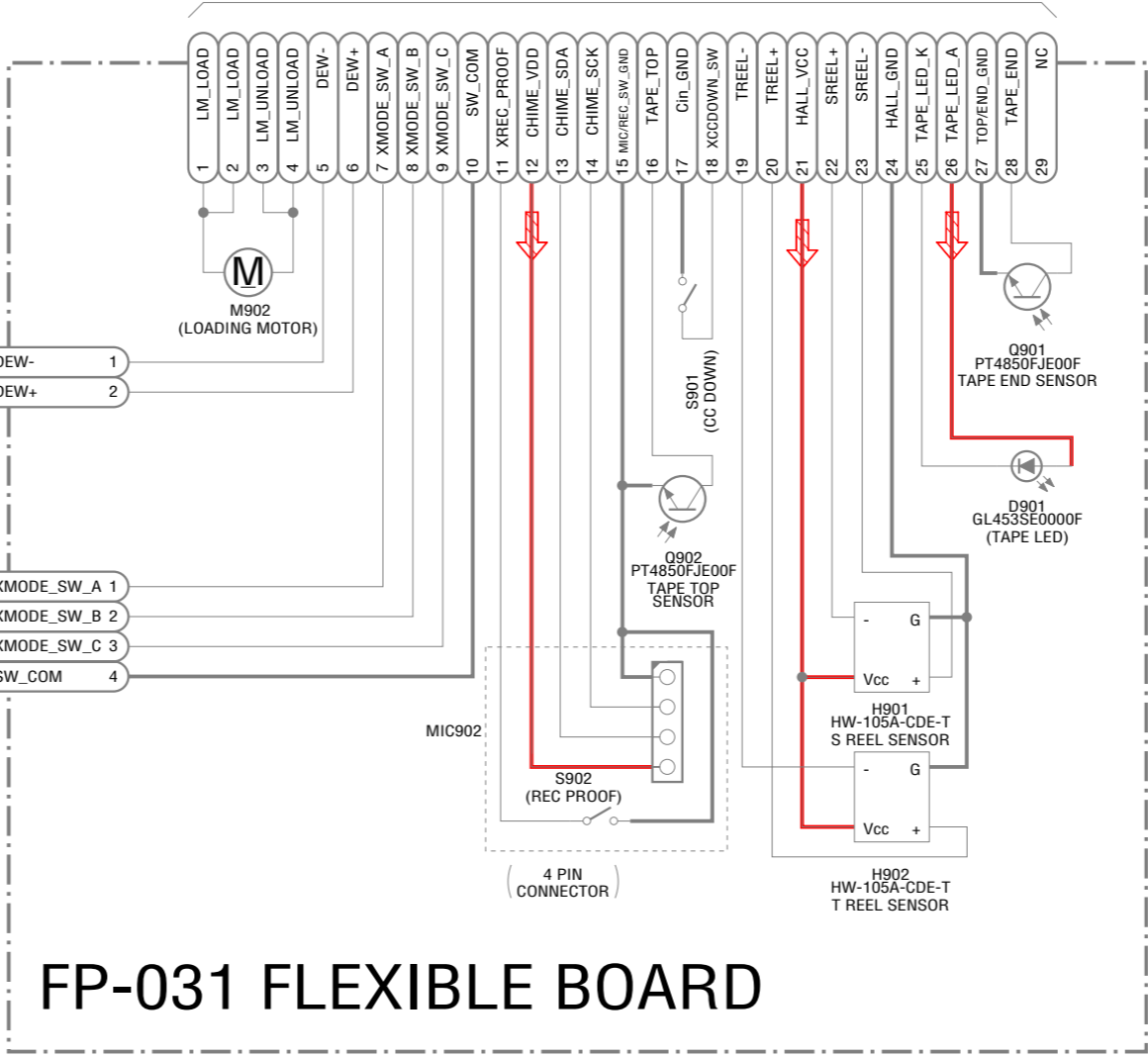
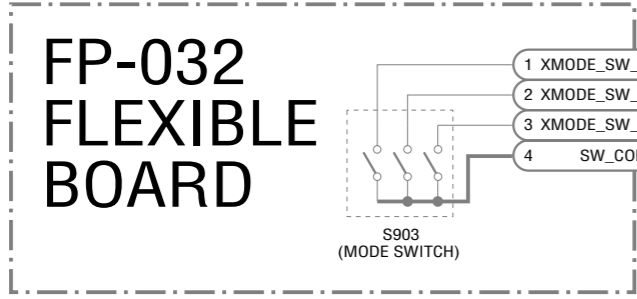
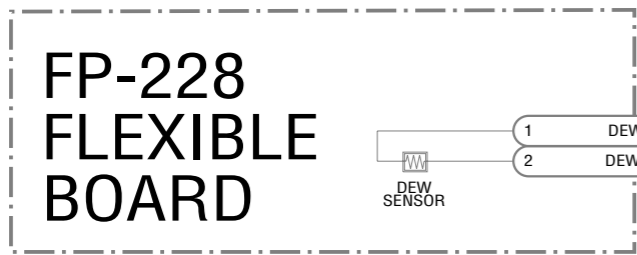

Note: The FP-031 and FP-032 are supplied as the assembled part of the MD (N220) sub ass'y (S) A by attaching them with the adhesive agent. These parts are not separately supplied because assembling of these parts requires high accuracy.







## 4-3. PLACAS DE CIRCUITO IMPRESSO

### Link

<a href="#">• PLACA CD-735</a>	<a href="#">• PLACA JK-367</a>
<a href="#">• PLACA PD-358 (SIDE A)</a>	<a href="#">• PLACA LB-137</a>
<a href="#">• PLACA PD-358 (SIDE B)</a>	<a href="#">• PLACA FLEXIVEL FP-386</a>
<a href="#">• PLACA AV-125</a>	<a href="#">• PLACA FLEXIVEL FP-626</a>
<a href="#">• PLACA CF-111 (SIDE A)</a>	<a href="#">• PLACA FLEXIVEL FP-031, FP-032, FP-228</a>
<a href="#">• PLACA CF-111 (SIDE B)</a>	
<a href="#">• NOTA COMUM PARA PLACAS DE CIRCUITO IMPRESSO</a>	

4-3. PLACAS DE CIRCUITO IMPRESSO

THIS NOTE IS COMMON FOR PRINTED WIRING BOARDS

-  : Uses unleaded solder.
-  : Circuit board
-  : Flexible board
-  : Pattern from the side which enables seeing.
-  : pattern of the rear side  
(The other layers' patterns are not indicated)
- Through hole is omitted.
- There are a few cases that the part printed on diagram isn't mounted in this model.
-  : panel designation

- Chip parts.

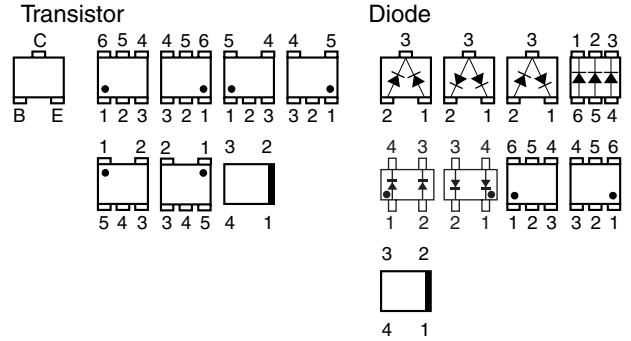

### CD-735 BOARD (SIDE A)

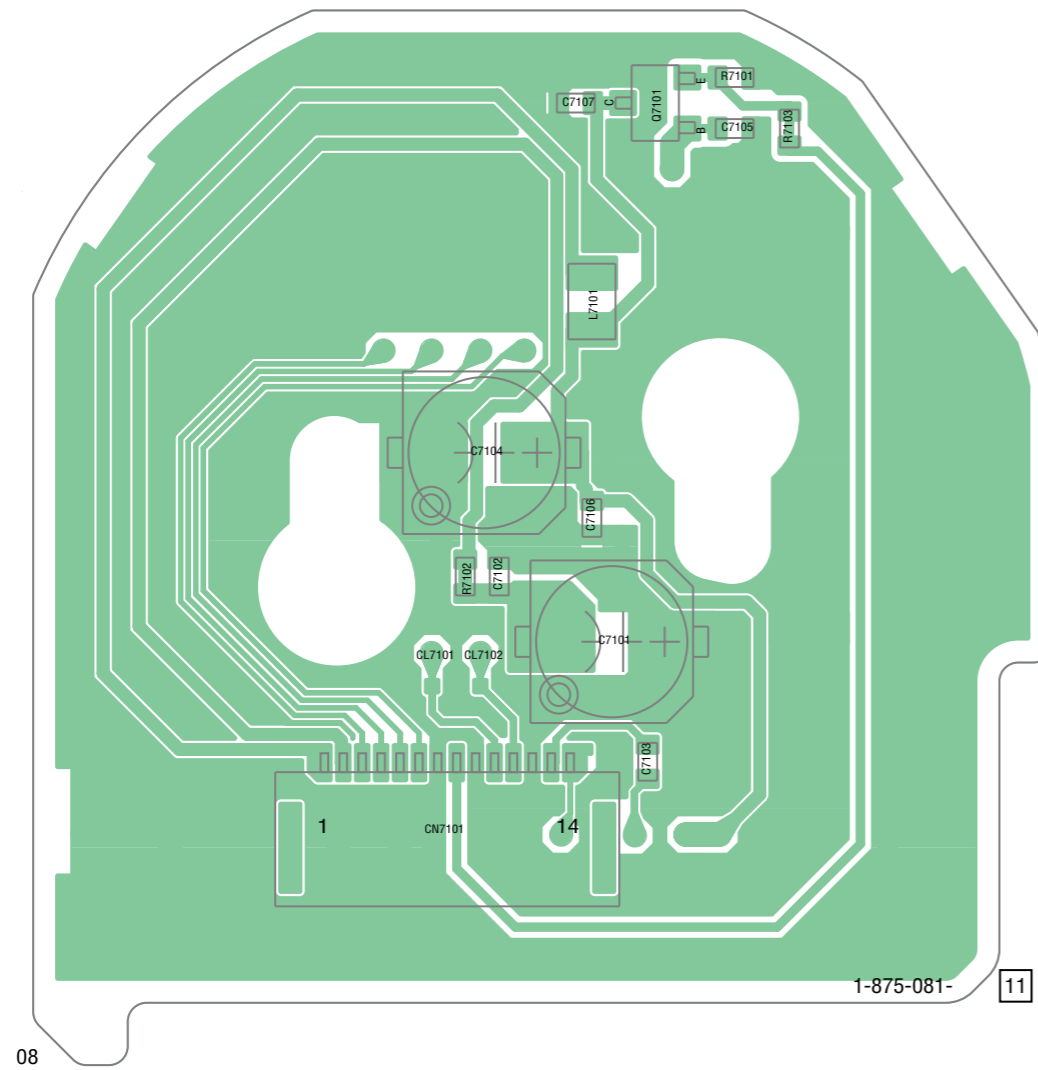

### CD-735 BOARD (SIDE B)

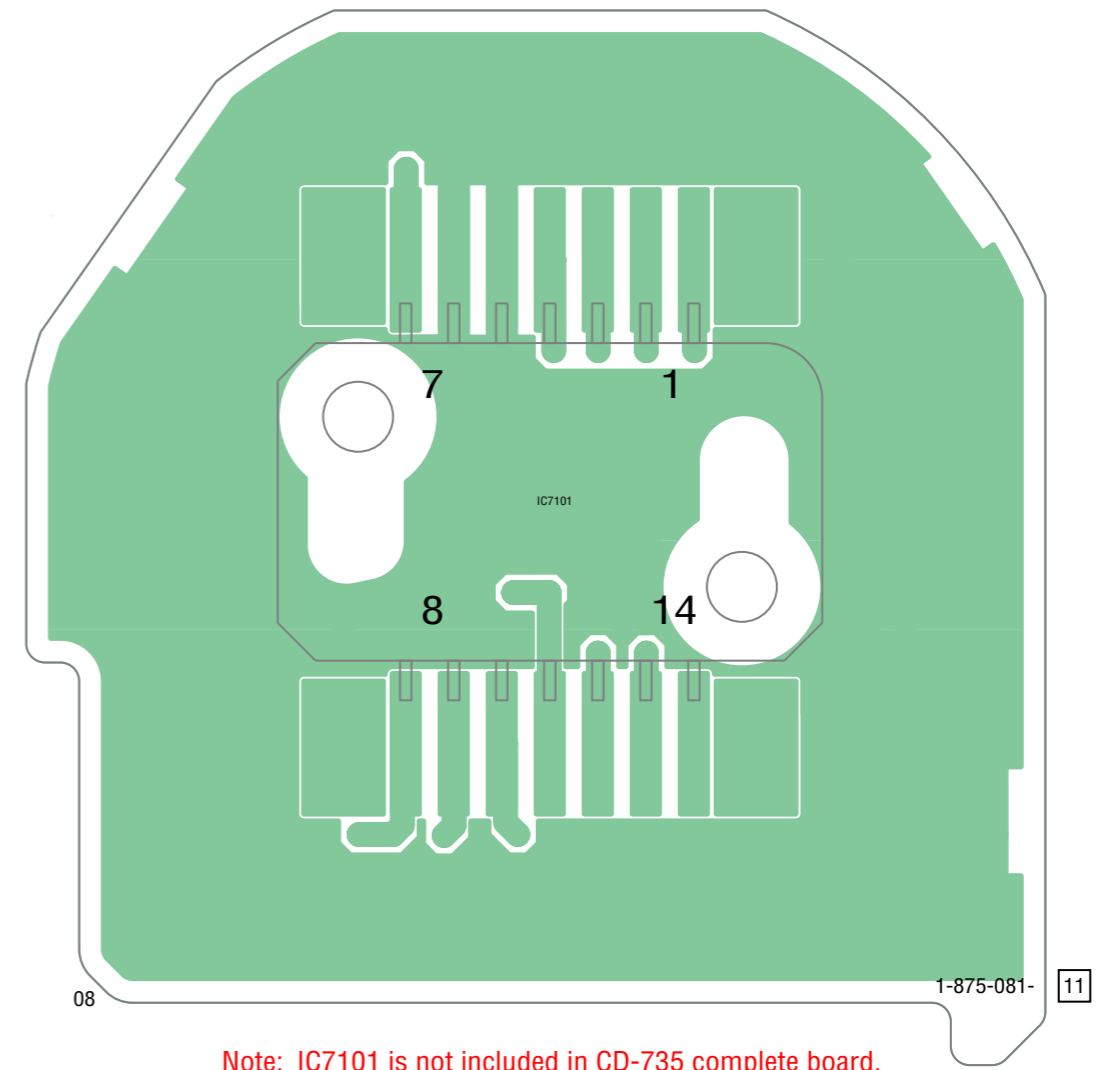

Note: IC7101 is not included in CD-735 complete board.

Placas de circuito impresso da placa VC-537 não são mostradas.  
Páginas 4-26 e 4-27 não são mostradas.



# PD-358 BOARD (SIDE A)

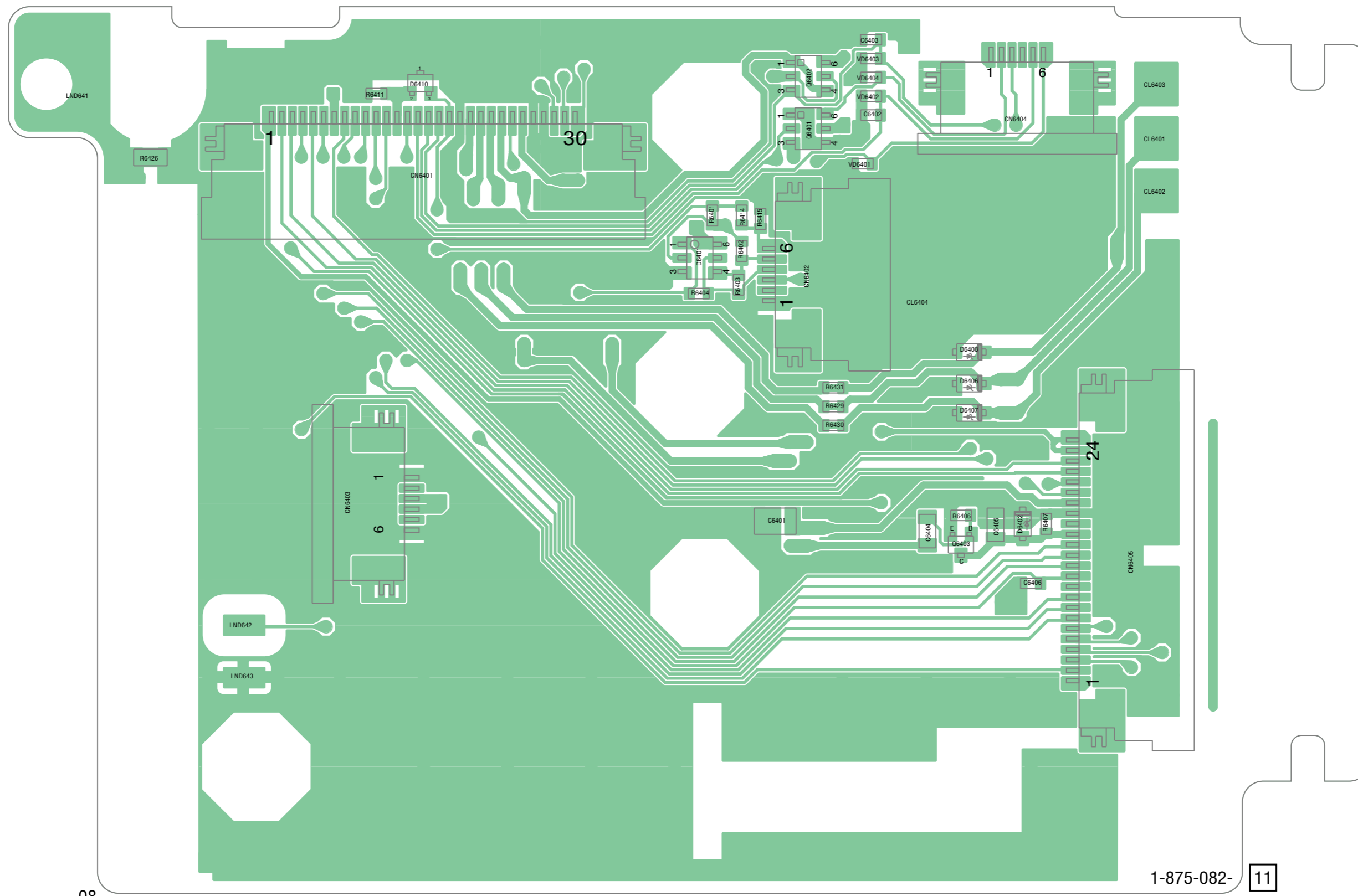

Note: LCD901 is not included in PD-358 complete board.

## PD-358 BOARD (SIDE B)



Note: LCD901 is not included in PD-358 complete board.

 : Uses unleaded solder.

### AV-125 BOARD (SIDE A)

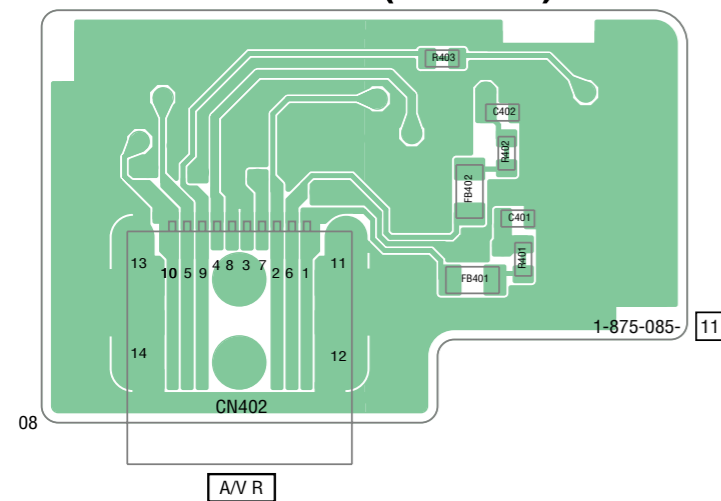

### AV-125 BOARD (SIDE B)

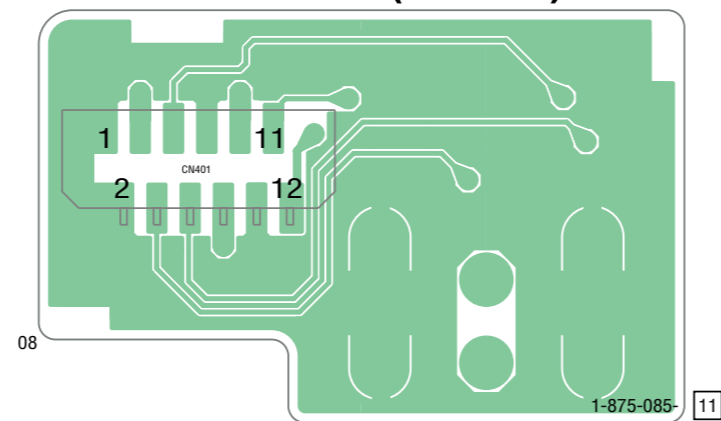

### LB-137 BOARD (SIDE A)

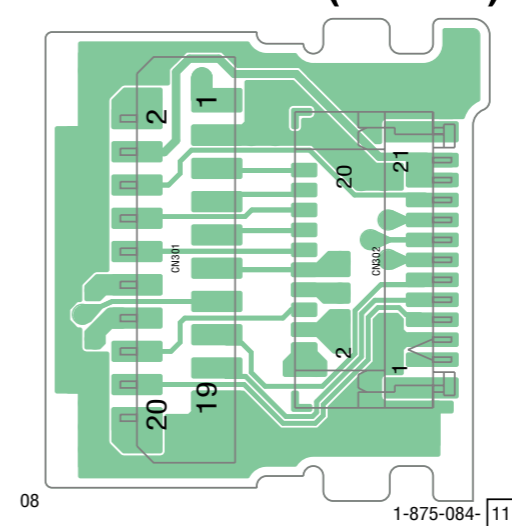

Note: LCD902 is not included in LB-137 complete board.

### LB-137 BOARD (SIDE B)

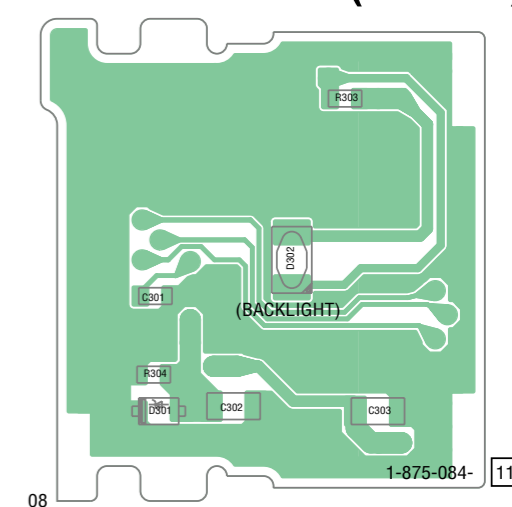

### JK-367 BOARD (SIDE A)

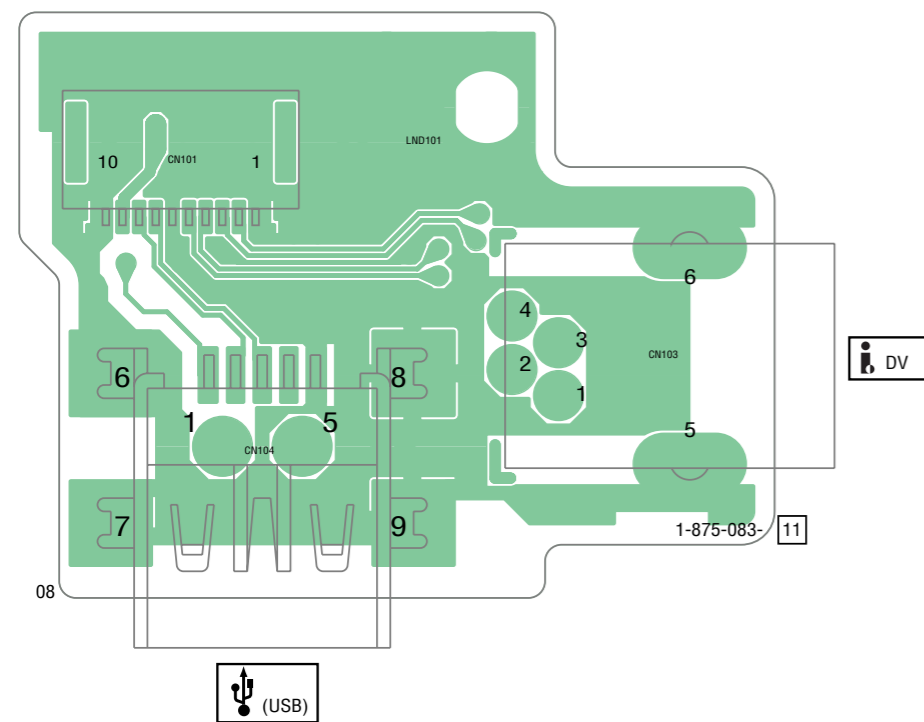

### JK-367 BOARD (SIDE B)

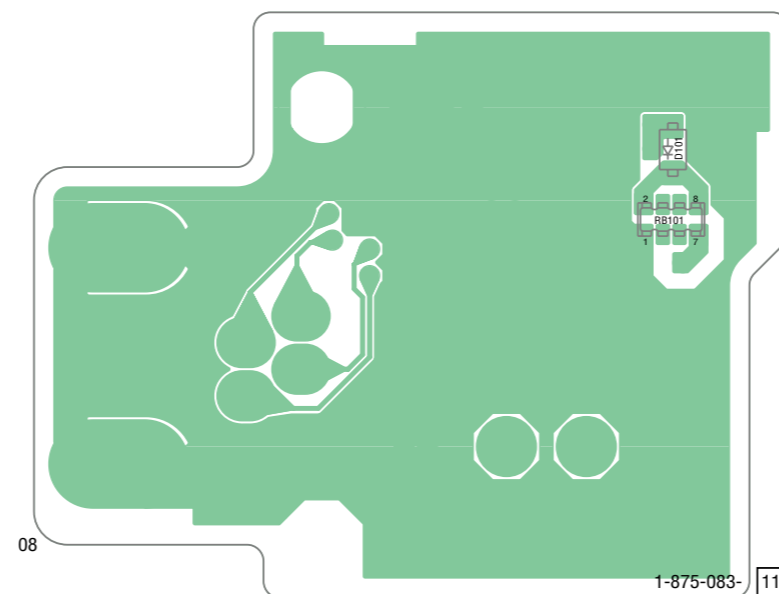

# CF-111 BOARD (SIDE A)

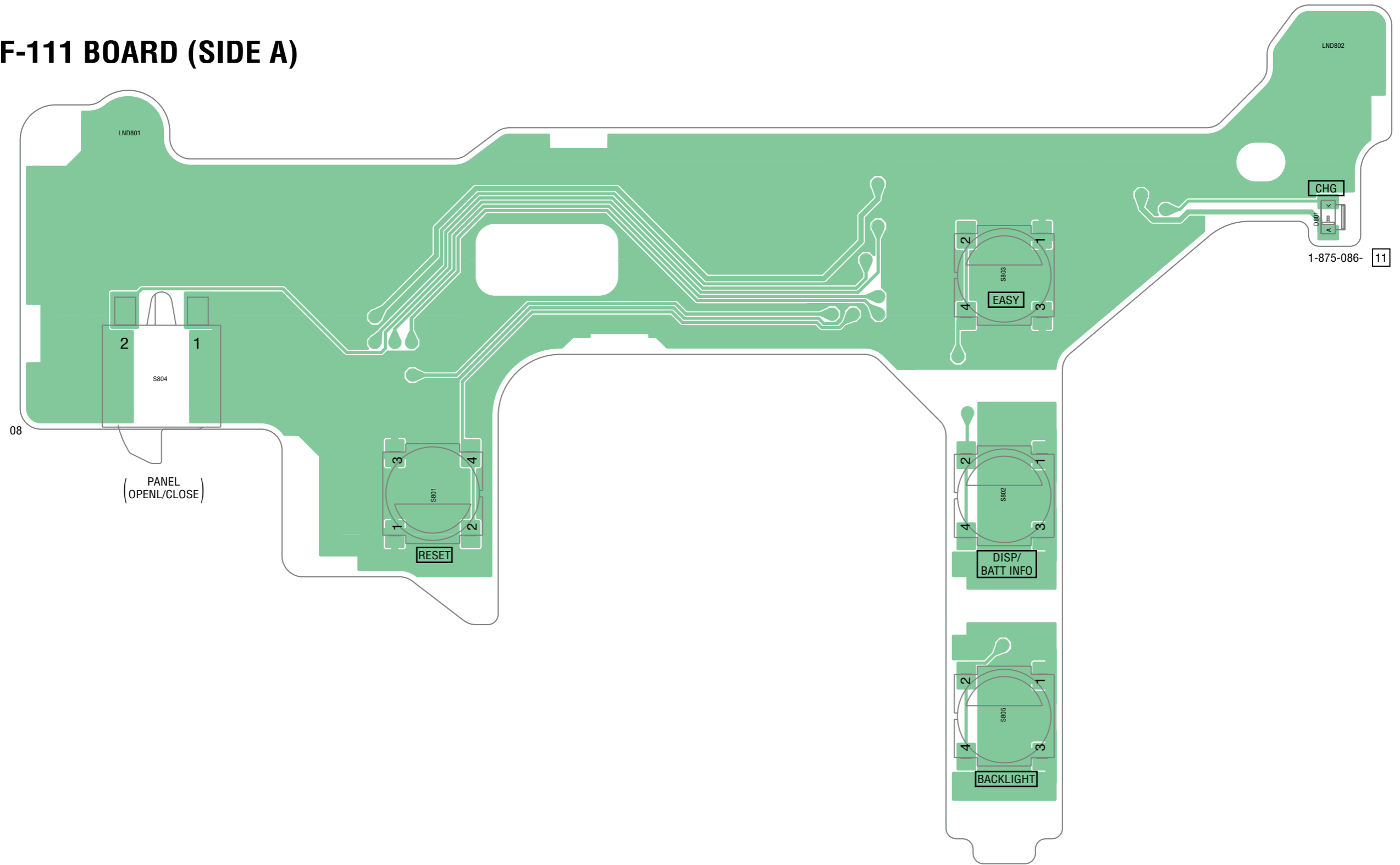

**CAUTION**  
Danger of explosion if battery is incorrectly replaced.  
Replace only with the same or equivalent type.

Note: Replace the battery holder (BH801) together when replacing the lithium storage battery (BT901) on the CF-111 board. (The battery holder removed once cannot be used again.) When mounting these parts, mount new battery holder first and attach new lithium storage battery next.

## CF-111 BOARD (SIDE B)

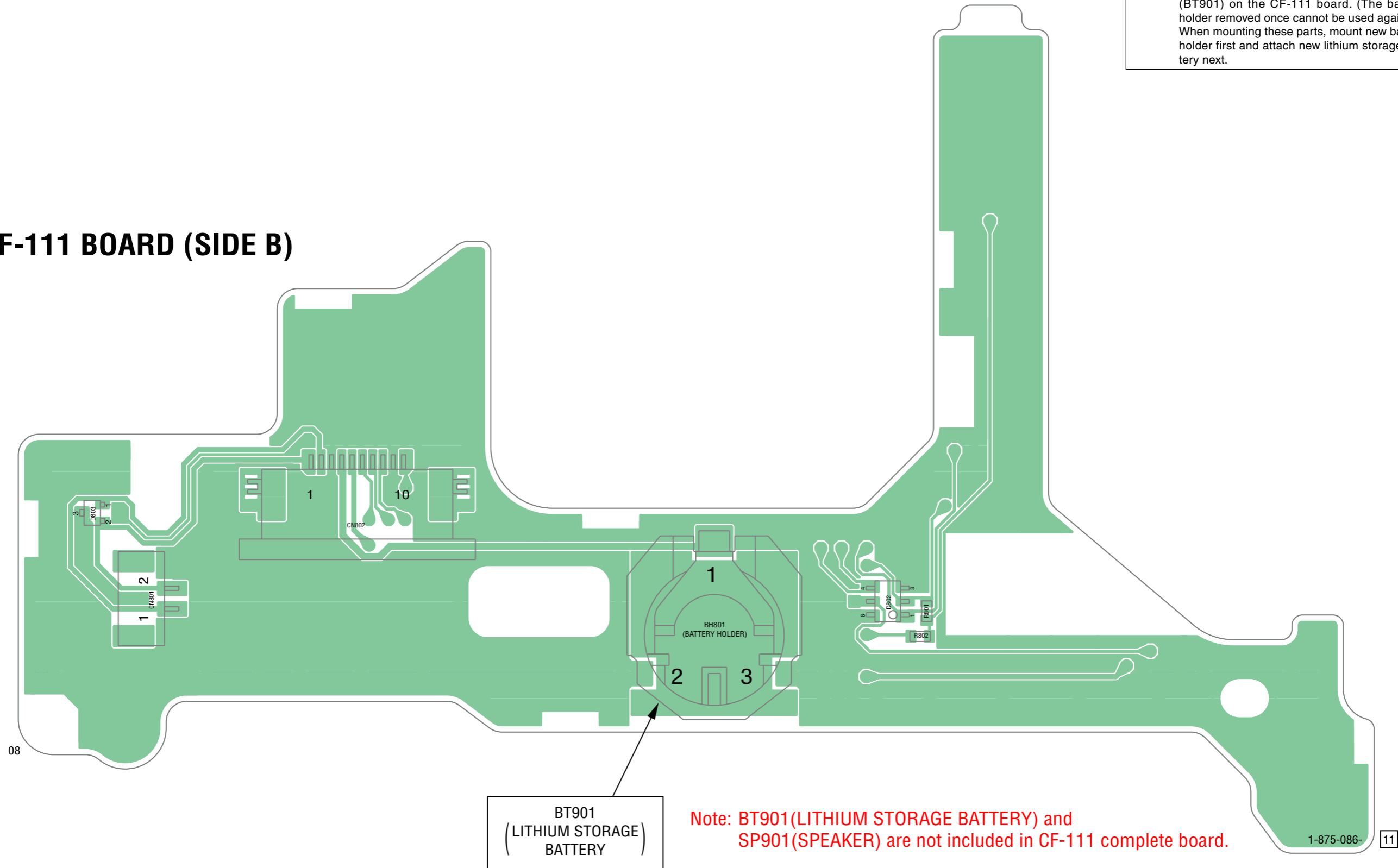

 : Uses unleaded solder.

### FP-386 FLEXIBLE BOARD

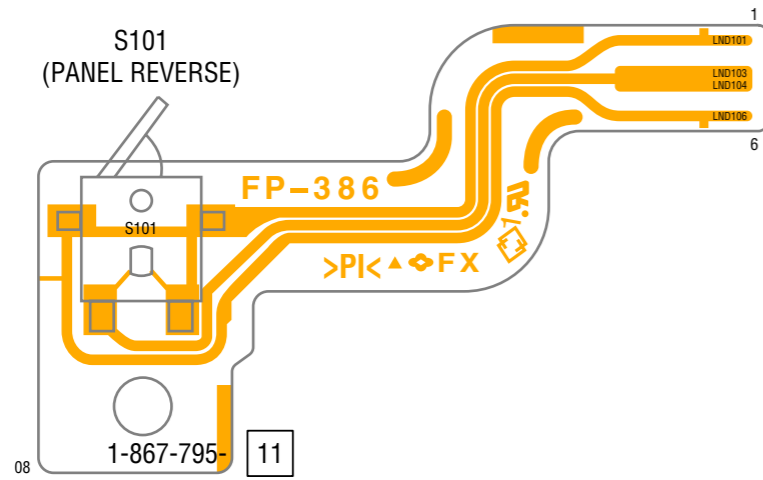

### FP-626 FLEXIBLE BOARD

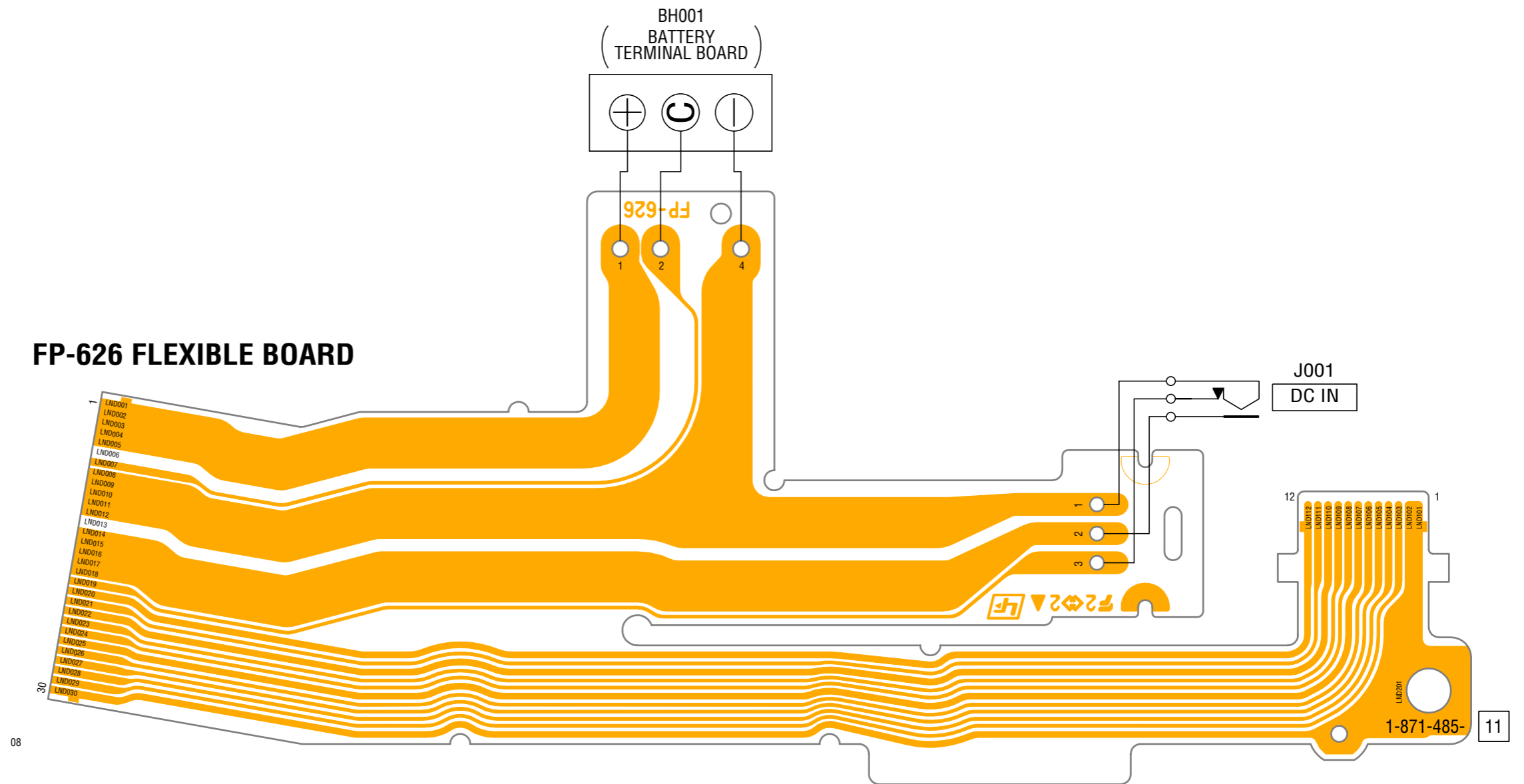

Note: BH001 and J001 are not included in FP-626 flexible board.

 : Uses unleaded solder.

Note: The FP-031 and FP-032 are supplied as the assembled part of the MD (N220) sub ass'y (S) A by attaching them with the adhesive agent. These parts are not separately supplied because assembling of these parts requires high accuracy.

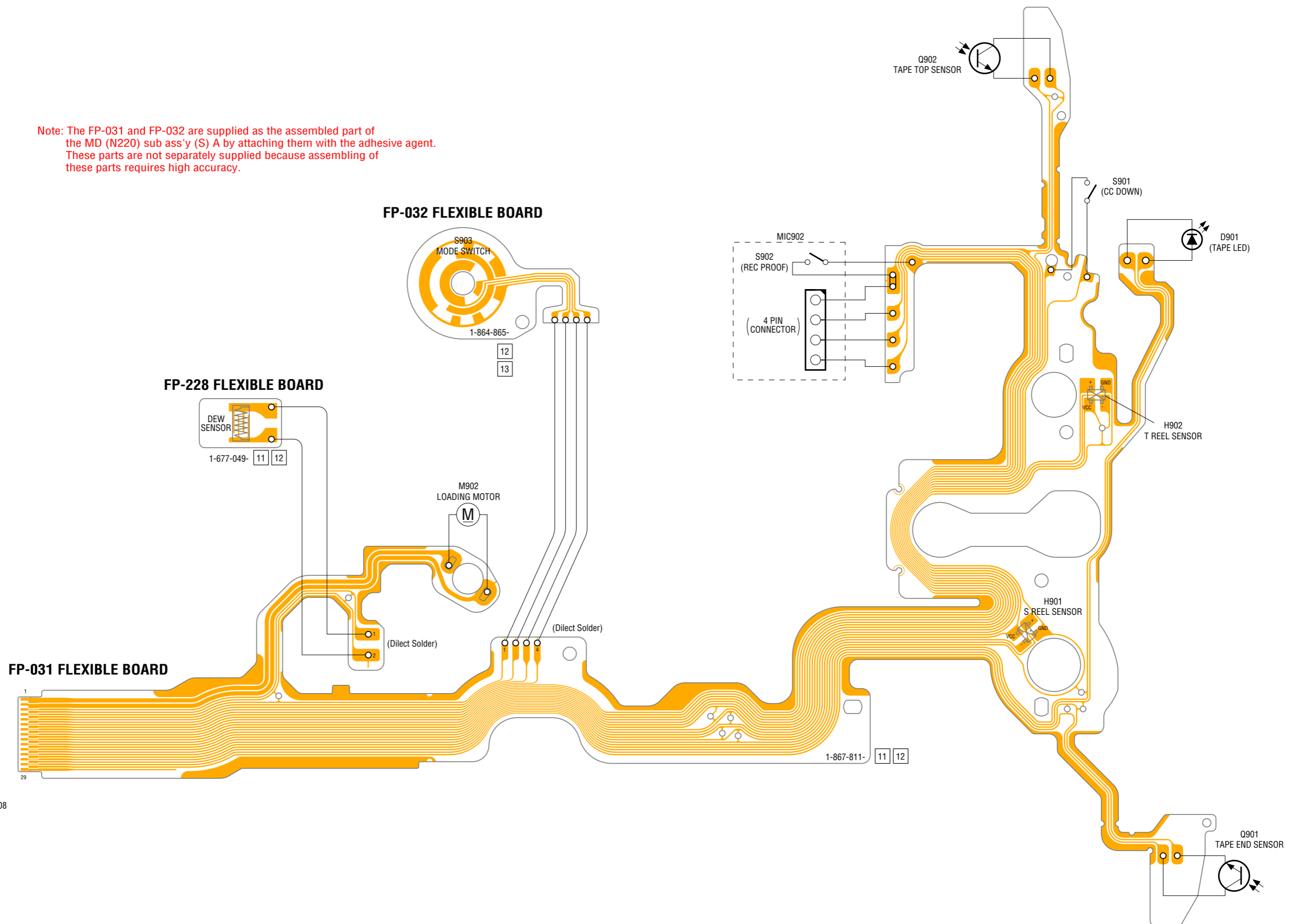

08

## 5. LISTA DE PEÇAS PARA REPARO

NOTE: Characters **A** to **Z** of the electrical parts list indicate location of exploded views in which the desired part is shown.

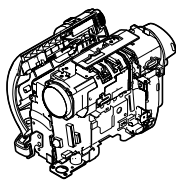
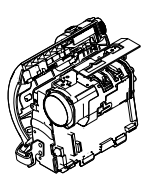
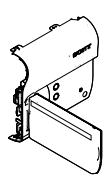
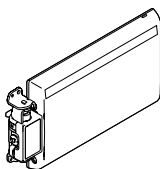
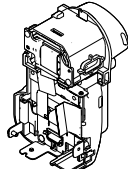
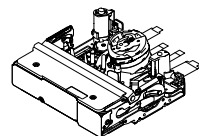
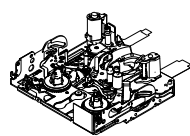
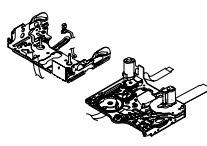
Link	VISTA EXPLODIDA		
 <b>A</b>	 <b>B</b>	 <b>C</b>	 <b>D</b>
SEÇÃO GERAL	SEÇÃO DA ESTRUTURA INFERIOR	SEÇÃO DO GABINETE (L)	SEÇÃO DO GABINETE (R)
 <b>E</b>	 <b>F</b>	 <b>G</b>	 <b>H</b>
BLOCO DO PAINEL LCD	SEÇÃO BT-EVF	SEÇÃO MECANISMO DECK	LS/MECHANICAL CHASSIS BLOCK ASSEMBLY-1
 <b>I</b>			
LS/MECHANICAL CHASSIS BLOCK ASSEMBLY-2			

Link	LISTA DE PEÇAS ELÉTRICAS		ACESSÓRIOS
• PLACA AV-125 <b>F</b>	• PLACA FLEXIVEL FP-032 <b>I</b>	• PLACA FLEXIVEL FP-626 <b>F</b>	
• PLACA CD-735 <b>C</b>	• PLACA FLEXIVEL FP-228 <b>I</b>	• PLACA JK-367 <b>B</b>	
• PLACA CF-111 <b>D</b>	• PLACA FLEXIVEL FP-386 <b>E</b>	• PLACA LB-137 <b>F</b>	
• PLACA FLEXIVEL FP-031 <b>I</b>	• PLACA FLEXIVEL FP-625 <b>E</b>	• PLACA PD-358 <b>E</b>	



## 5. LISTA DE PEÇAS PARA REPARO

### 5. LISTA DE PEÇAS PARA REPARO

#### NOTE:

- -XX, -X mean standardized parts, so they may have some differences from the original one.
- Items marked "\*" are not stocked since they are seldom required for routine service. Some delay should be anticipated when ordering these items.
- The mechanical parts with no reference number in the exploded views are not supplied.
- Due to standardization, replacements in the parts list may be different from the parts specified in the diagrams or the components used on the set.
- CAPACITORS:  
uF:  $\mu\text{F}$
- COILS  
uH:  $\mu\text{H}$
- RESISTORS  
All resistors are in ohms.  
METAL: metal-film resistor  
METAL OXIDE: Metal Oxide-film resistor  
F: nonflammable
- SEMICONDUCTORS  
In each case, u:  $\mu$ , for example:  
uA...:  $\mu\text{A}$ ..., uPA...,  $\mu\text{PA}$ ...,  
uPB...,  $\mu\text{PB}$ ..., uPC...,  $\mu\text{PC}$ ...,  
uPD...,  $\mu\text{PD}$ ...

When indicating parts by reference number, please include the board name.

The components identified by mark  $\triangle$  or dotted line with mark  $\triangle$  are critical for safety. Replace only with part number specified.

Les composants identifiés par une marque  $\triangle$  sont critiques pour la sécurité. Ne les remplacer que par une pièce portant le numéro spécifié.

- Color Indication of Appearance Parts  
Example:  
(SILVER) : Cabinet's Color  
(Silver) : Parts Color

# 5. LISTA DE PEÇAS PARA REPARO

DESMONTAGEM

LISTA DE PARAFUSOS

## 5-1. VISTA EXPLODIDAS

### 5-1-1. Seção Geral

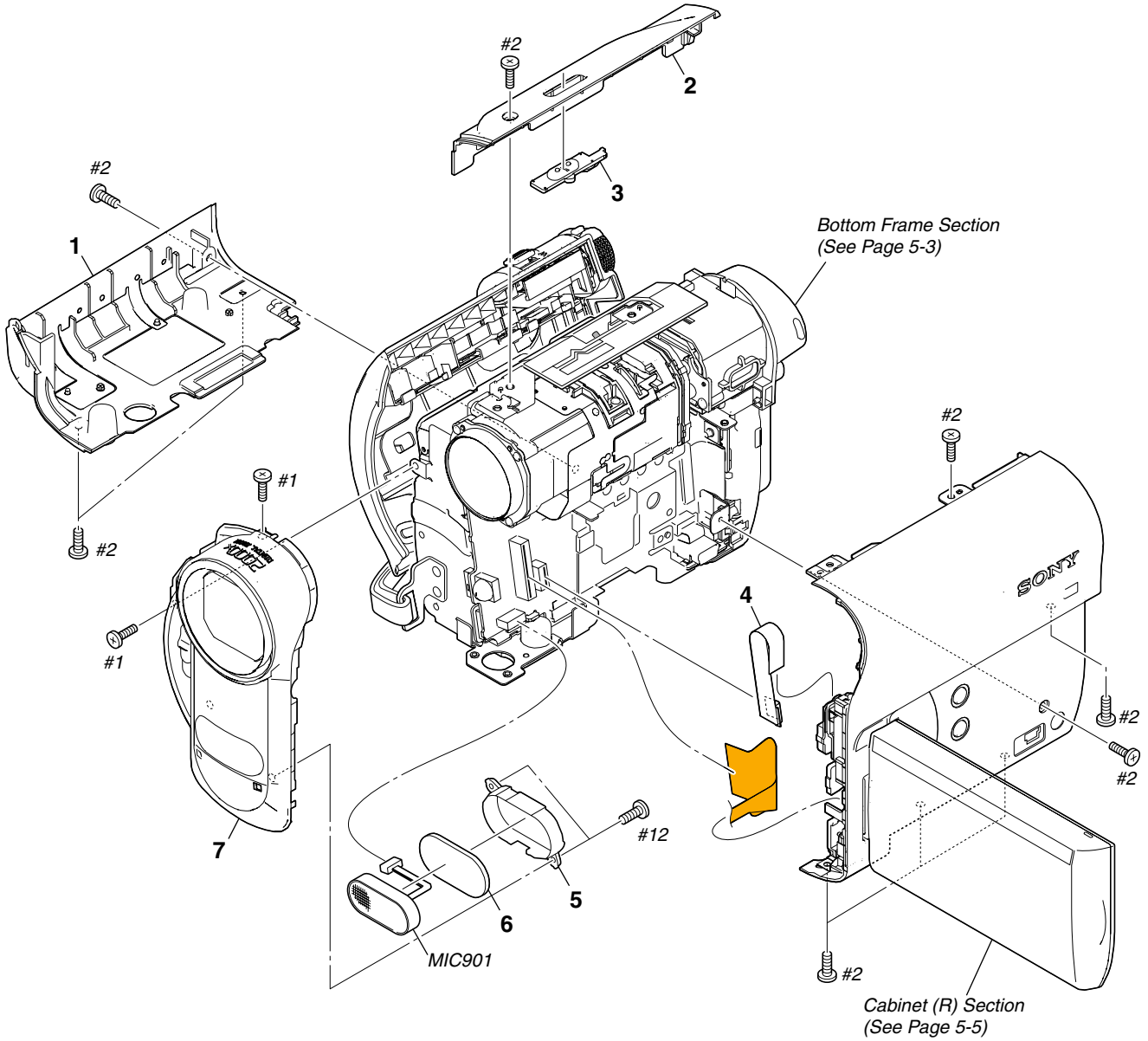

Ref. No.	Part No.	Description
1	2-899-764-21	CABINET (L)
2	3-271-259-01	CABINET (UPPER (2122))
3	2-899-771-11	KNOB (212), NS
4	1-833-206-11	CABLE, FLEXIBLE FLAT (FFC-085)
5	2-899-716-01	RETAINER, MICROPHONE
6	2-899-717-01	CUSHION, MICROPHONE

Ref. No.	Part No.	Description
7	X-2186-671-1	PANEL (2122) ASSY, F
MIC901	1-542-712-11	MICROPHONE UNIT
#1	2-635-562-11	SCREW (M1.7) (Black)
#2	2-635-562-31	SCREW (M1.7) (Black)
#12	3-080-204-21	SCREW, TAPPING, P2 (Black)

## 5. LISTA DE PEÇAS PARA REPARO

DESMONTAGEM

LISTA DE PARAFUSOS

### 5-1-2. SEÇÃO DA ESTRUTURA INFERIOR

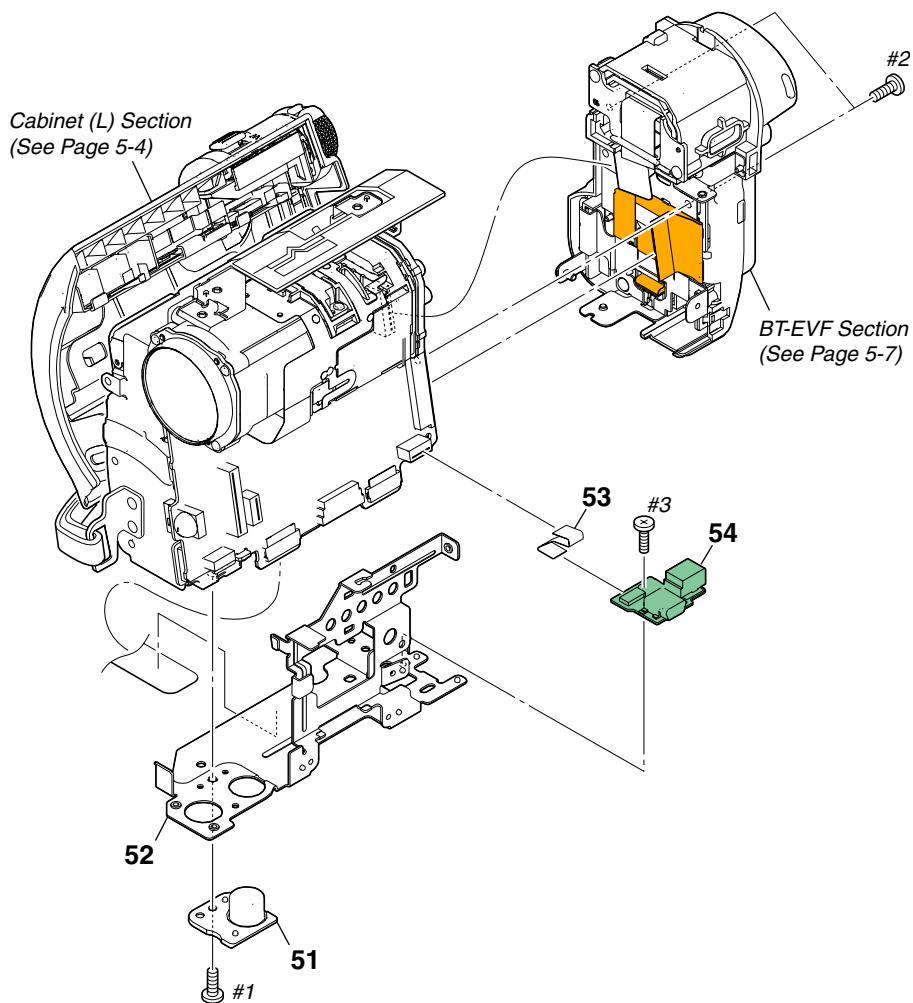

Ref. No.	Part No.	Description
51	2-899-769-01	SCREW, TRIPOD
* 52	2-899-767-01	FRAME, BOTTOM
* 53	1-833-211-11	CABLE, FLEXIBLE FLAT (FFC-090)
54	A-1438-778-A	JK-367 BOARD, COMPLETE

Ref. No.	Part No.	Description
#1	2-635-562-11	SCREW (M1.7) (Black)
#2	2-635-562-31	SCREW (M1.7) (Black)
#3	2-660-401-01	SCREW (M1.7), NEW TRU-STAR, P2 (Red)

# 5. LISTA DE PEÇAS PARA REPARO

DESMONTAGEM

LISTA DE PARAFUSOS

## 5-1-3. SEÇÃO CABINETE (L)

ns: não fornecido

Mechanism Deck Section  
(See Page 5-8)

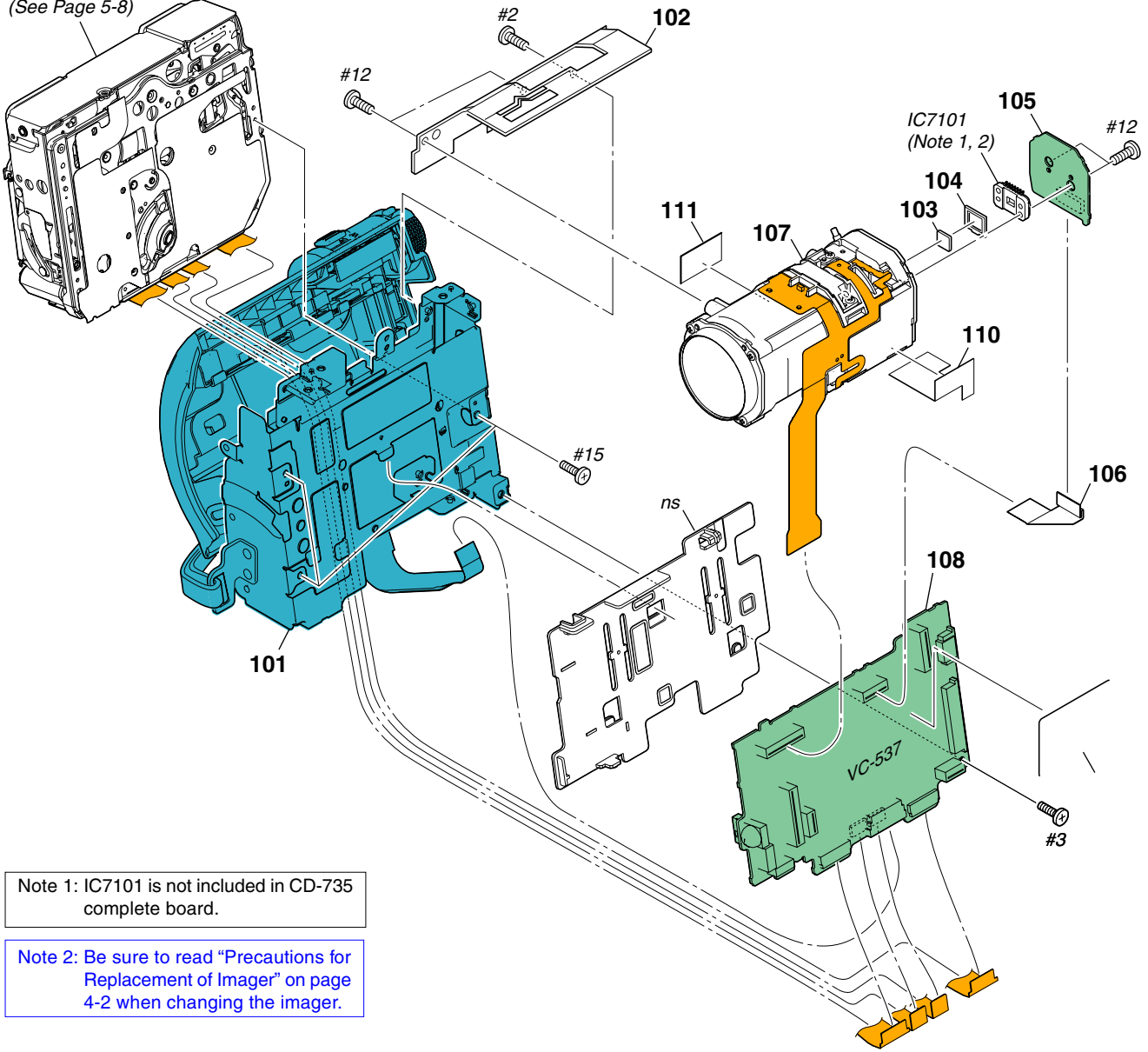

Note 1: IC7101 is not included in CD-735 complete board.

Note 2: Be sure to read "Precautions for Replacement of Imager" on page 4-2 when changing the imager.

Ref. No.	Part No.	Description
101	1-479-928-41	KEY BLOCK, CONTROL (SS21200)
102	2-899-770-01	PLATE, NS CLICK
103	1-788-706-11	OPTICAL FILTER BLOCK (OFB-08-02)
104	3-271-382-01	SEAL RUBBER 1171
105	A-1438-759-A	CD-735 BOARD, COMPLETE
106	1-833-675-11	FLEXIBLE FLAT CABLE (FFC-003)
107	8-848-839-01	DEVICE, LENS LSV-1171A
108	A-1496-718-A	VC-537 BOARD, COMPLETE (SERVICE)
109	2-659-500-01	LABEL, FUSE REPLACEMENT CAUTION

Ref. No.	Part No.	Description
* 110	3-095-521-01	SHEET/GUARD
* 111	2-675-602-01	SHEET, F INSULATING
IC7101	8-753-244-70	ICX610NKF-13 (CCD IMAGER) (Note 1, 2)
#2	2-635-562-31	SCREW (M1.7) (Black)
#3	2-660-401-01	SCREW (M1.7), NEW TRU-STAR, P2 (Red)
#12	3-080-204-21	SCREW, TAPPING, P2 (Black)
#15	3-062-214-01	SCREW (M1.4X1.5) (Silver)

5-1-4. SEÇÃO GABINETE (R).

ns: não fornecido

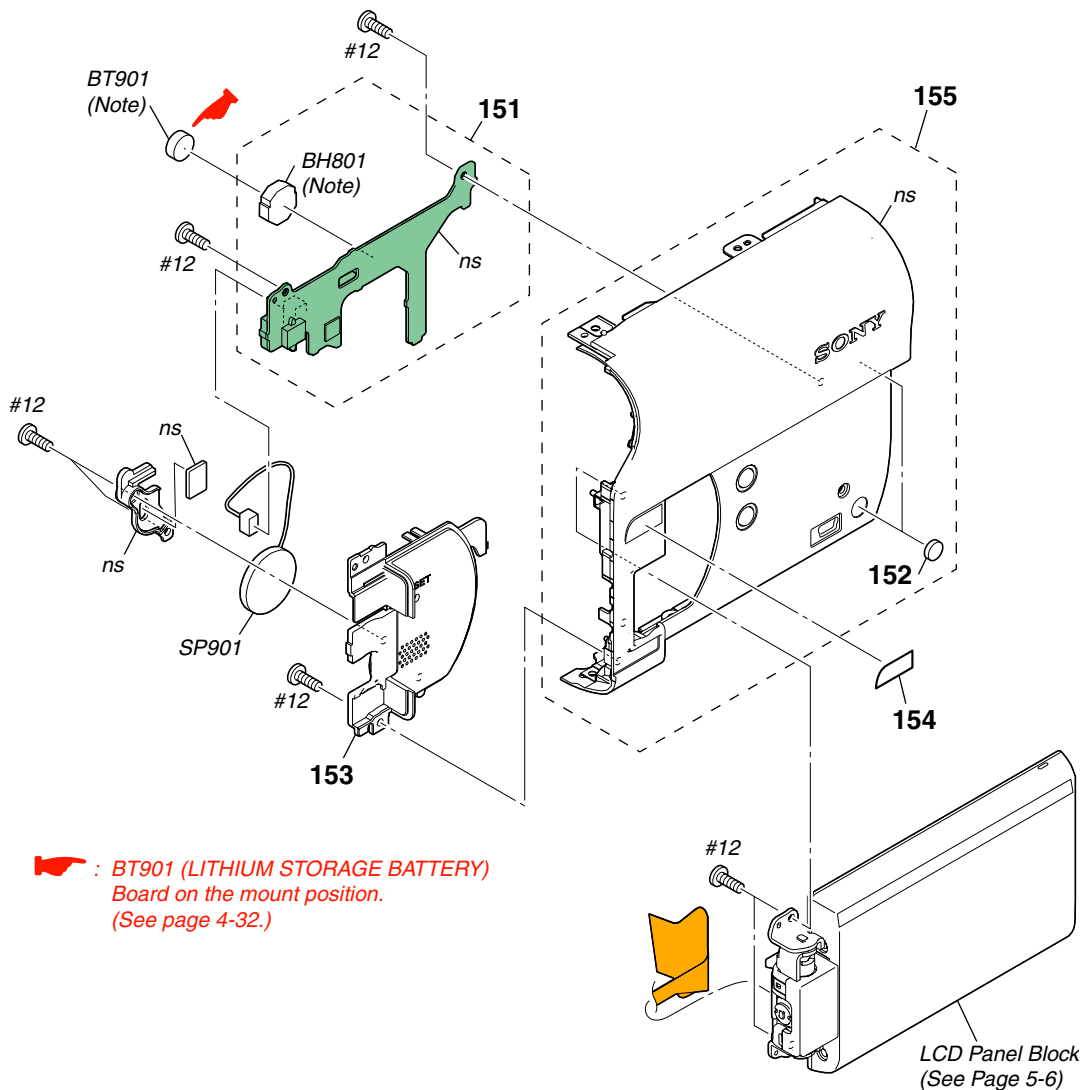

 : BT901 (LITHIUM STORAGE BATTERY)  
Board on the mount position.  
(See page 4-32.)

LCD Panel Block  
(See Page 5-6)

Note: Replace the battery holder (BH801) together when replacing the lithium storage battery (BT901) on the CF-111 board. (The battery holder removed once cannot be used again.) When mounting these parts, mount new battery holder first and attach new lithium storage battery next.

**CAUTION**  
Danger of explosion if battery is incorrectly replaced.  
Replace only with the same or equivalent type.

• Refer to page 5-1 for mark  $\triangle$ .

Ref. No.	Part No.	Description
151	A-1438-782-A	CF-111 BOARD, COMPLETE
152	3-089-565-01	CUSHION (R), PANEL
153	X-2186-695-1	BLIND (2122) ASSY, HINGE
154	3-268-973-01	SHEET (R), MIRROR
155	X-2186-668-1	CABINET (R (2122)) ASSY

Ref. No.	Part No.	Description
$\triangle$ BH801	1-756-615-41	HOLDER, BATTERY (Note)
$\triangle$ BT901	1-756-134-12	BATTERY, STORAGE, LITHIUM (Note)
SP901	1-825-260-51	LOUD SPEAKER (1.6CM)
#12	3-080-204-21	SCREW, TAPPING, P2 (Black)

## 5. LISTA DE PEÇAS PARA REPARO

### LISTA DE PARAFUSOS

### 5-1-5. BLOCO DO PAINEL LCD

ns: não fornecido

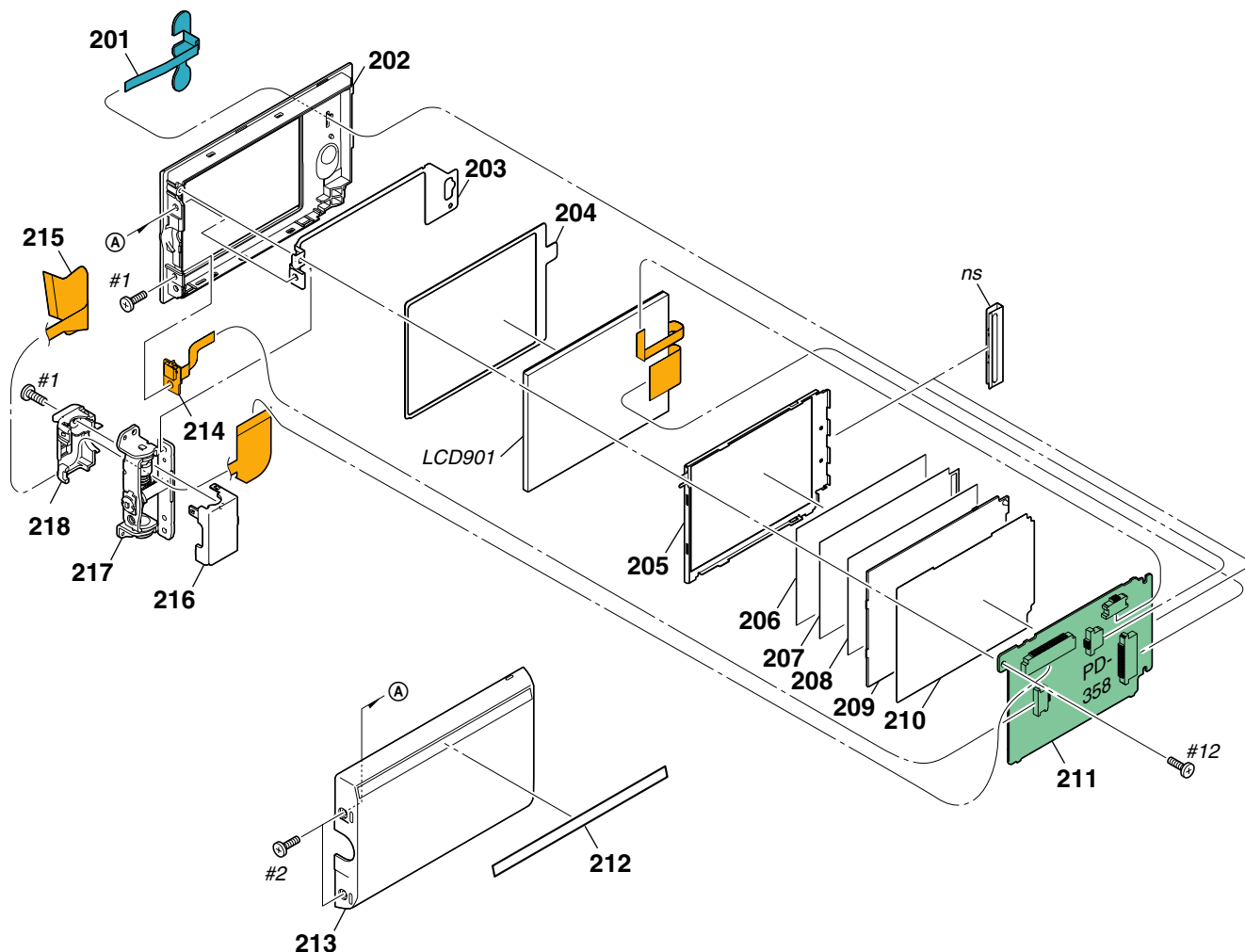

Ref. No.	Part No.	Description
201	1-479-063-21	KEY BLOCK, CONTROL (SB9000)
202	3-272-758-01	CABINET (M (2122)), P
* 203	2-899-744-01	PLATE (212), LCD GROUND
* 204	2-899-746-01	CUSHION (2.5), TP
205	2-694-511-01	FRONT FRAME (2.5)
206	2-694-507-01	PRISM SHEET V (2.5)
207	2-694-508-01	PRISM SHEET H (2.5)
208	2-694-509-01	DIFFUSION SHEET (2.5)
209	2-666-791-01	LIGHT GUIDE (2.5)
210	2-694-510-01	REFLECTION SHEET (2.5)
211	A-1438-760-A	PD-358 BOARD, COMPLETE
212	3-268-972-01	SHEET (P), MIRROR

Ref. No.	Part No.	Description
213	3-271-260-01	CABINET (C (2122)), P
214	A-1153-842-A	FP-386 FLEXIBLE BOARD, COMPLETE
215	1-871-484-21	FP-625 FLEXIBLE BOARD
216	3-271-261-01	COVER (C (2122)), HINGE
217	X-2149-207-1	HINGE ASSY (M), PANEL
218	2-899-737-01	COVER (M), HINGE
LCD901	A-1149-654-A	TP BLOCK ASSY (25STMG06)
#1	2-635-562-11	SCREW (M1.7) (Black)
#2	2-635-562-31	SCREW (M1.7) (Black)
#12	3-080-204-21	SCREW, TAPPING, P2 (Black)

5-1-6. SEÇÃO BT-EVF

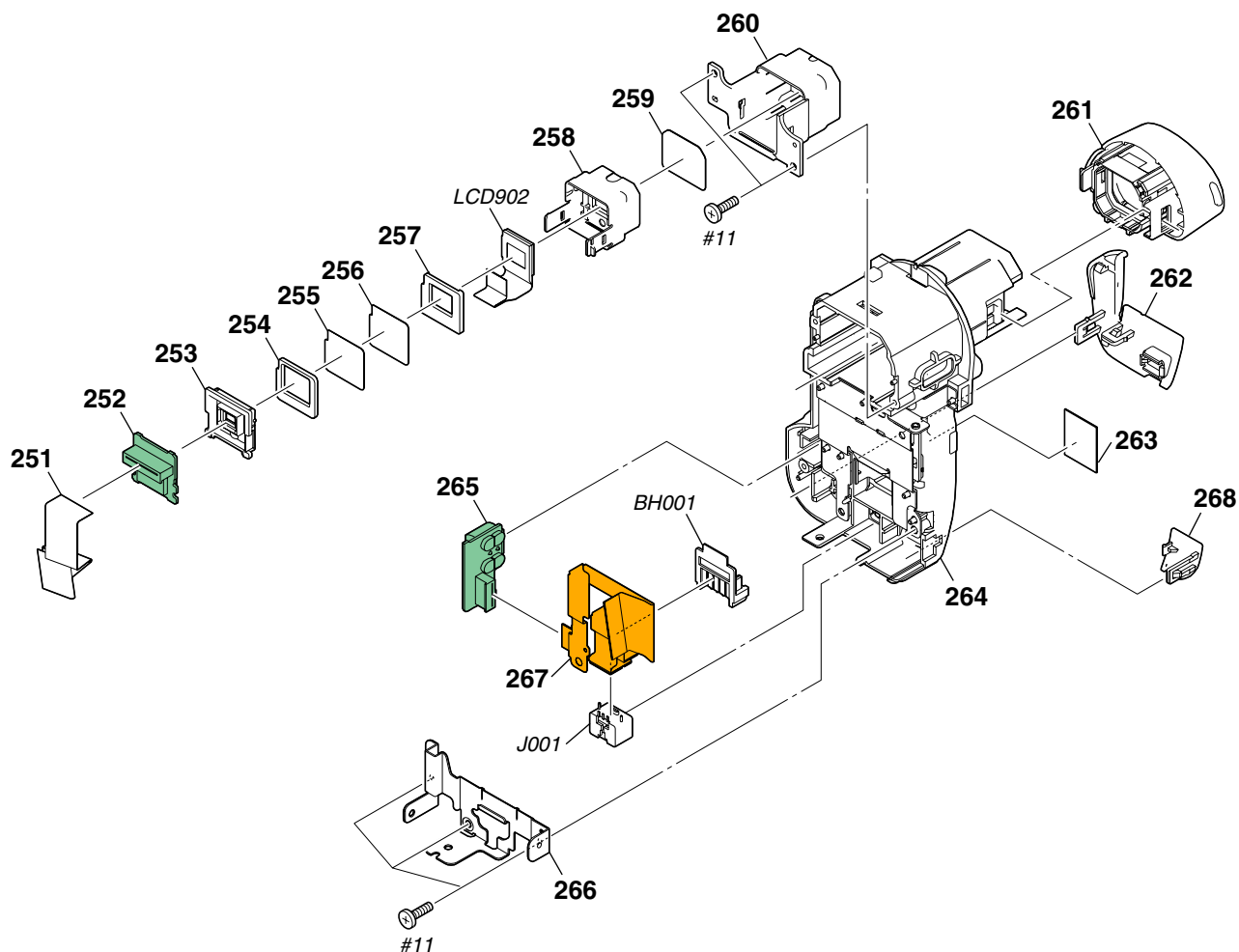

• Refer to page 5-1 for mark △.

Ref. No.	Part No.	Description
* 251	1-833-205-11	CABLE, FLEXIBLE FLAT (FFC-084)
252	A-1438-780-A	LB-137 BOARD, COMPLETE
253	2-664-672-01	GUIDE, LAMP
* 254	2-638-819-01	CUSHION, LCD
* 255	2-638-818-01	ILLUMINATOR
* 256	2-638-816-01	PLATE (TFT), DEFLECTION
257	2-664-671-01	SPACER, LCD
258	2-899-658-01	CAP (212), INNER
259	2-899-660-01	PANEL (CF), POLARIZATION
260	2-899-657-01	CABINET, INNER
261	X-2188-331-1	EYE CUP (2122) ASSY
262	2-899-886-11	COVER, DC-AV
263	2-899-887-11	LID, CPC

Ref. No.	Part No.	Description
264	X-2188-329-1	BT-VF (2122) ASSY
265	A-1438-781-A	AV-125 BOARD, COMPLETE
266	2-899-661-01	FRAME, TERMINAL FIXED
* 267	1-871-485-11	FP-626 FLEXIBLE BOARD
268	2-899-885-11	COVER, DV
△ BH001	1-780-064-21	BATTERY TERMINAL BOARD
△ J001	1-815-792-11	CONNECTOR, DC-IN (7.2V)
LCD902	8-753-245-09	LCX059CKK-1
#11	3-078-890-11	SCREW, TAPPING (Silver)

## 5. LISTA DE PEÇAS PARA REPARO

### 5-1-7. SEÇÃO DO MECANISMO DECK

ns: não fornecido

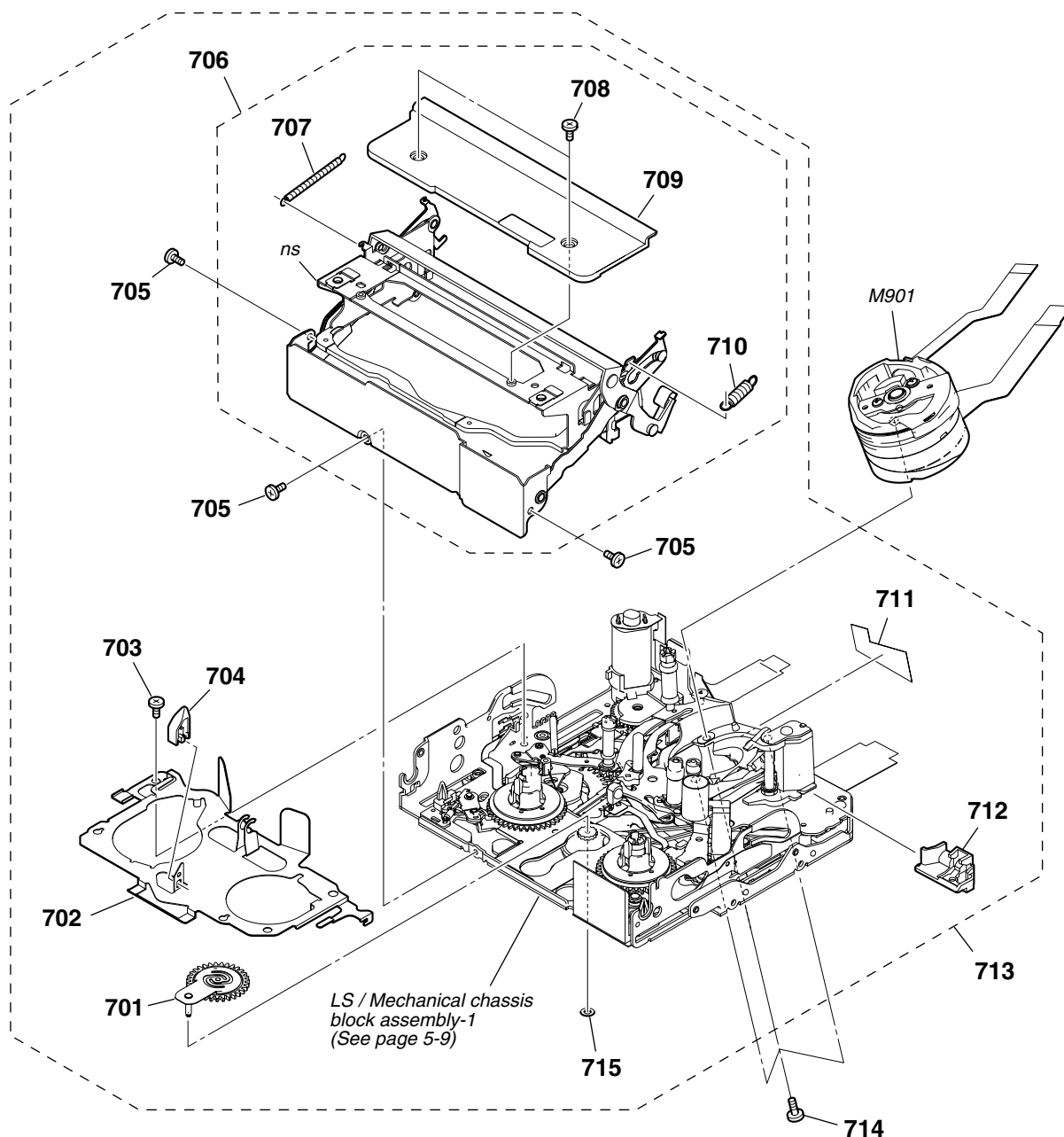

Ref. No.	Part No.	Description
701	X-2024-478-1	PENDULUM ASSY
702	2-342-917-02	BASE, LED
703	7-627-850-77	SCREW, PRECISION +P 1.4X1.8
704	3-079-366-11	RELEASE, REEL LOCK
705	3-703-816-08	SCREW (M1.4X1.4), SPECIAL HEAD
706	X-2024-450-3	CASSETTE COMPARTMENT ASSY
707	2-342-926-01	SPRING (ARM S), TENSION COIL
708	2-546-417-01	SCREW (M1.4X1.0)
709	2-342-933-02	PLATE, TOP

Ref. No.	Part No.	Description
710	2-342-927-01	SPRING (ARM T), TENSION COIL
711	2-541-585-01	SHEET, FLEXIBLE ADHESIVE
712	2-342-918-01	TG6 CATCHER
713	A-1437-006-A	MD (N220) SUB ASSY (S) A
714	3-703-816-13	SCREW (M1.4X2.0), SPECIAL HEAD
715	3-315-414-31	WASHER
M901	A-1154-545-A	DRUM (DEH-33E-R)



## 5. LISTA DE PEÇAS PARA REPARO

### 5-1-8. BLOCO DE CHASSI MECÂNICO LS MONTADO-1

ns: não fornecido

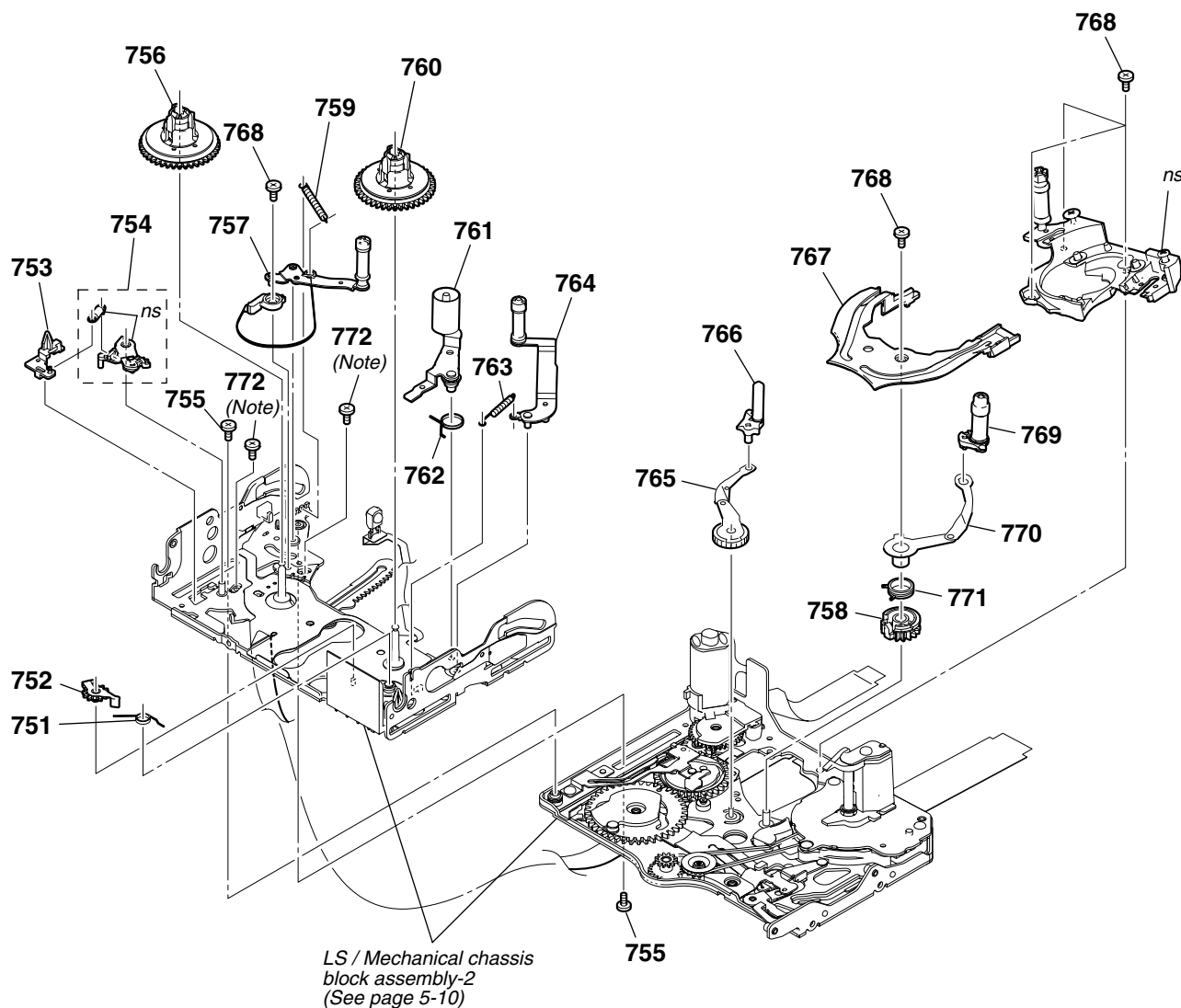

**Note:** These two screws are the fixing screws of the LS cam plate.  
These two fixing screws are used for adjusting the LS cam plate position.  
(refer to 4-2. LS cam adjustment of DV mechanical adjustment manual IX)

Ref. No.	Part No.	Description	Ref. No.	Part No.	Description
751	2-342-759-01	SPRING, RVS BRAKE	763	2-342-626-01	SPRING (RETURN TG6), EXTENSION
752	A-1083-005-A	BRAKE BLOCK ASSY, RVS	764	A-1083-002-A	BLOCK ASSY, TG6
753	2-342-731-01	POSITIONING, S	765	X-2024-468-1	ARM ASSY (S) , GL
754	A-1083-006-A	BLOCK ASSY, S BRAKE	766	X-2024-465-1	COASTER (S) ASSY
755	3-075-097-11	SCREW (M1.4X1.4), SPECIAL HEAD	767	2-342-612-01	RAIL
756	X-2067-290-1	TABLE ASSY, S REEL	768	3-703-816-13	SCREW (M1.4X2.0), SPECIAL HEAD
757	A-1132-279-A	REGULATOR BLOCK ASSY, TENSION	769	X-2024-466-1	COASTER (T) ASSY
758	2-342-705-01	GEAR (T), GL	770	X-2024-469-1	ARM (T) ASSY, GL
759	2-342-902-01	SPRING, TENSION REGULATOR	771	2-342-716-01	SPRING (T), TORSION COIL
760	X-2067-291-1	TABLE ASSY, T REEL	772	3-703-816-08	SCREW (M1.4X1.4), SPECIAL HEAD (for adjustment) (Note)
761	X-2067-295-4	ARM ASSY, PINCH			
762	2-342-906-01	SPRING (PINCH RETURN), TORSION			

## 5. LISTA DE PEÇAS PARA REPARO

### 5-1-9. BLOCO DE CHASSI MECÂNICO LS MONTADO-2

ns: não fornecido

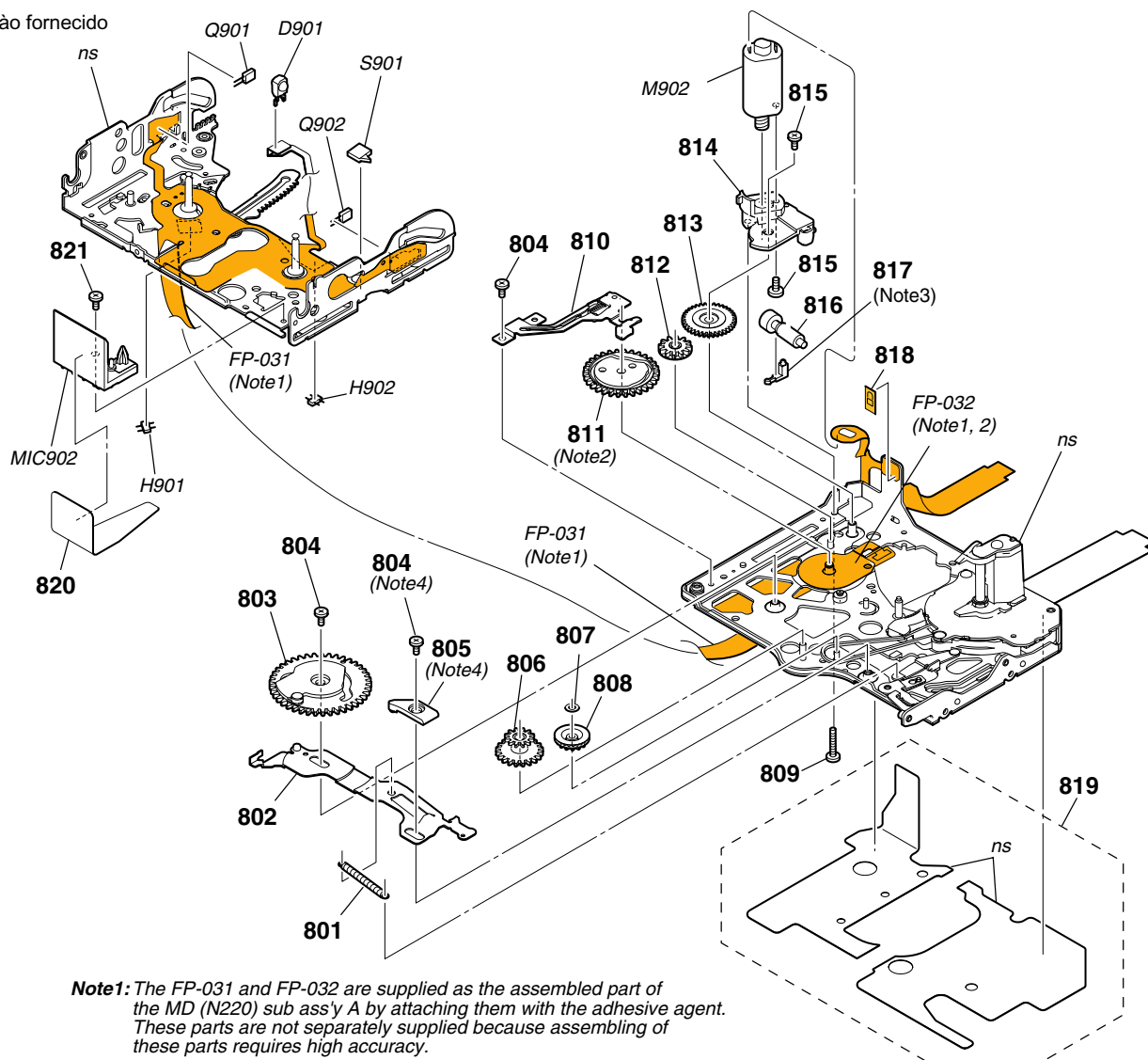

**Note1:** The FP-031 and FP-032 are supplied as the assembled part of the MD (N220) sub ass'y A by attaching them with the adhesive agent. These parts are not separately supplied because assembling of these parts requires high accuracy.

**Note2:** The mode switch (S903) function works when the contactor of the FP-032 contacts with the bottom surface of wiper of the mode gear ass'y.

**Note3:** When replacing the motor holder or the motor holder base, be sure to replace them together as a pair.

**Note4:** Some sets do not have this screw or the EJ lever retainer. For the sets that have them, follow the installation procedure (3-30-2. Attachment procedure (page 40) of DV mechanical adjustment manual IX) for installation.

Ref. No.	Part No.	Description	Ref. No.	Part No.	Description
801	2-342-624-01	SPRING (PINCH LIMITTER), EXTEN	818	1-677-049-11	FP-228 FLEXIBLE BOARD (DEW SENSOR)
802	X-2024-463-2	SLIDER ASSY, MODE	819	2-342-686-01	COVER, CAPSTAN
803	X-2024-462-3	GEAR ASSY, CAM	820	2-541-984-01	MIC COVER
804	3-075-097-11	SCREW (M1.4X1.4), SPECIAL HEAD (Note 4)	821	3-703-816-13	SCREW (M1.4X2.0), SPECIAL HEAD
805	2-342-625-01	RETAINER, LEVER EJ (Note 4)	D901	6-500-652-01	DIODE GL453SE0000F (TAPE LED)
806	2-342-621-01	GEAR, RELAY	H901	8-719-067-74	ELEMENT, HOLE HW-105A-CDE-T (S REEL SENSOR)
807	3-315-414-31	WASHER	H902	8-719-067-74	ELEMENT, HOLE HW-105A-CDE-T (T REEL SENSOR)
808	2-342-620-01	GEAR, CONVERSION	M902	X-2024-464-1	MOTOR ASSY (LOADING MOTOR)
809	3-084-377-01	HEAD (SCREW M1.2)	MIC902	1-818-576-11	PIN, CONNECTOR (WITH DETECTION) (4 PIN CONNECTOR)
810	X-2024-460-1	BASE ASSY, CAM	Q901	6-550-672-01	TRANSISTOR PT4850FJE00F (TAPE END SENSOR)
811	X-2024-461-1	GEAR ASSY, MODE (Note 2)	Q902	6-550-672-01	TRANSISTOR PT4850FJE00F (TAPE TOP SENSOR)
812	2-342-615-01	GEAR, NO.2	S901	1-786-448-22	SWITCH, PUSH (1 KEY) (CC DOWN)
813	2-342-691-01	GEAR, NO.1			
814	2-637-945-01	HOLDER, MOTOR			
815	3-895-822-71	SCREW (M1.2X2), SPECIAL, 0			
816	2-342-689-01	WORM SHAFT (2J)			
817	2-637-947-01	BASE, MOTOR HOLDER (Note 3)			

## 5-2. LISTA DE PEÇAS ELÉTRICAS

Ref. No.	Part No.	Description
	A-1438-781-A	AV-125 BOARD, COMPLETE *****
		< CONNECTOR >
CN401	1-779-330-51	CONNECTOR, FFC/FPC 12P
CN402	1-815-794-13	CONNECTOR (MULTIPLE) (A/V R)
		< FERRITE BEAD >
FB401	1-500-238-11	BEAD, FERRITE (CHIP) (1608)
FB402	1-500-238-11	BEAD, FERRITE (CHIP) (1608)
	A-1438-759-A	CD-735 BOARD, COMPLETE *****
(IC7101 is not included in CD-735 complete board.)		
		< CAPACITOR >
C7101	1-124-779-00	ELECT CHIP 10uF 20% 16V
C7103	1-100-567-81	CERAMIC CHIP 0.01uF 10% 25V
C7104	1-124-779-00	ELECT CHIP 10uF 20% 16V
C7105	1-164-850-11	CERAMIC CHIP 10PF 0.5PF 50V
		< CONNECTOR >
* CN7101	1-818-045-51	CONNECTOR, FFC/FPC 14P
		< IC >
IC7101	8-753-244-70	IC ICX610NKF-13 (CCD IMAGER)
		< COIL >
L7101	1-400-588-11	INDUCTOR 10uH
		< TRANSISTOR >
* Q7101	6-551-873-01	TRANSISTOR 2SC3931G0LS0
		< RESISTOR >
R7101	1-218-959-11	RES-CHIP 3.3K 5% 1/16W
	A-1438-782-A	CF-111 BOARD, COMPLETE *****
(BT901 (LITHIUM STORAGE BATTERY) and SP901 (SPEAKER) are not included in CF-111 complete board.)		
		< SPEAKER >
SP901	1-825-260-51	LOUD SPEAKER (1.6CM)
		< BATTERY HOLDER >
△ BH801	1-756-615-41	HOLDER, BATTERY (Note 2)
		< BATTERY >
△ BT901	1-756-134-12	BATTERY, STORAGE, LITHIUM (Note 2)

• Refer to page 5-1 for mark △.

Ref. No.	Part No.	Description
		< CONNECTOR >
CN801	1-794-057-11	PIN, CONNECTOR (PC BOARD) 2P
* CN802	1-766-646-51	CONNECTOR, FFC/FPC 10P
		< DIODE >
* D801	6-501-573-01	DIODE CL-271TLY-C-TS (CHG)
		< RESISTOR >
R801	1-218-955-11	RES-CHIP 1.5K 5% 1/16W
R802	1-218-957-11	RES-CHIP 2.2K 5% 1/16W
		< SWITCH >
S801	1-786-157-31	TACTILE SWITCH (RESET)
S802	1-786-157-31	TACTILE SWITCH (DISP/BATT INFO)
S803	1-786-157-31	TACTILE SWITCH (EASY)
* S804	1-786-545-41	SWITCH, PUSH LEVER (S) (PANEL OPEN/CLOSE)
S805	1-786-157-31	TACTILE SWITCH (BACKLIGHT)
	(Not supplied)	FP-031 FLEXIBLE BOARD *****
(This flexible board is included in MD (N220) sub assy (S) A (A-1437-006-A).)		
		< DIODE >
D901	6-500-652-01	DIODE GL453SE0000F (TAPE LED)
		< HOLE ELEMENT >
H901	8-719-067-74	ELEMENT, HOLE HW-105A-CDE-T (S REEL SENSOR)
H902	8-719-067-74	ELEMENT, HOLE HW-105A-CDE-T (T REEL SENSOR)
		< CONNECTOR >
MIC902	1-818-576-11	PIN, CONNECTOR (WITH DETECTION) (4 PIN CONNECTOR)
		< TRANSISTOR >
Q901	6-550-672-01	TRANSISTOR PT4850FJE00F (TAPE END SENSOR)
Q902	6-550-672-01	TRANSISTOR PT4850FJE00F (TAPE TOP SENSOR)
		< SWITCH >
S901	1-786-448-22	SWITCH, PUSH (1 KEY) (CC DOWN)

(Not supplied) FP-032 FLEXIBLE BOARD  
\*\*\*\*\*

(This flexible board with S903 is included in MD (N220) sub assy A (A-1437-006-A).)

### CAUTION

Danger of explosion if battery is incorrectly replaced.  
Replace only with the same or equivalent type.

Note 1: Be sure to read "Precautions for Replacement of Imager" on page 4-2 when changing the imager.

Note 2: Replace the battery holder (BH801) together when replacing the lithium storage battery (BT901) on the CF-111 board. (The battery holder removed once cannot be used again.)  
When mounting these parts, mount new battery holder first and attach new lithium storage battery next.

Ref. No.	Part No.	Description
	1-677-049-11	FP-228 FLEXIBLE BOARD (DEW SENSOR) *****
(This flexible board is included in MD (N220) sub assy (S) A (A-1437-006-A).)		
	A-1153-842-A	FP-386 FLEXIBLE BOARD, COMPLETE *****
		< SWITCH >
S101	1-786-180-31	SWITCH, PUSH (1KEY) (PANEL REVERSE)
	1-871-484-21	FP-625 FLEXIBLE BOARD *****
(There isn't mounted electrical parts in FP-625 flexible board.)		
*	1-871-485-11	FP-626 FLEXIBLE BOARD *****
(BH001 and J001 are not included in FP-626 flexible board.)		
		< BATTERY TERMINAL BOARD >
△ BH001	1-780-064-21	BATTERY TERMINAL BOARD
		< JACK >
△ J001	1-815-792-11	CONNECTOR, DC-IN (7.2V) (DC IN)
	A-1438-778-A	JK-367 BOARD, COMPLETE *****
		< CONNECTOR >
* CN101	1-818-043-51	CONNECTOR, FFC/FPC 10P
* CN103	1-794-276-21	CONNECTOR, SQUARE TYPE 4P (DV)
	A-1438-780-A	LB-137 BOARD, COMPLETE *****
(LCD902 is not included in LB-137 complete board.)		
		< LIQUID CRYSTAL DISPLAY >
LCD902	8-753-245-09	LCX059CCK-1
		< CAPACITOR >
C301	1-125-777-11	CERAMIC CHIP 0.1uF 10% 10V
C302	1-165-908-11	CERAMIC CHIP 1uF 10% 10V

Ref. No.	Part No.	Description
		< CONNECTOR >
* CN301	1-779-334-51	CONNECTOR, FFC/FPC 20P
* CN302	1-817-560-71	CONNECTOR, FPC (ZIP) 21P
		< DIODE >
* D301	6-501-955-01	DIODE MAZS056G08S0
* D302	6-501-591-01	DIODE NESW007AT-T099 (BACKLIGHT)
		< RESISTOR >
R304	1-218-989-11	RES-CHIP 1M 5% 1/16W
	A-1438-760-A	PD-358 BOARD, COMPLETE *****
(LCD901 is not included in PD-358 complete board.)		
		< LIQUID CRYSTAL DISPLAY >
LCD901	A-1149-654-A	TP BLOCK ASSY (25STMG06)
		< CAPACITOR >
C6402	1-100-581-81	CERAMIC CHIP 0.0047uF 10% 50V
C6403	1-100-581-81	CERAMIC CHIP 0.0047uF 10% 50V
C6405	1-165-908-11	CERAMIC CHIP 1uF 10% 10V
C6406	1-125-777-11	CERAMIC CHIP 0.1uF 10% 10V
		< CONNECTOR >
* CN6401	1-818-072-51	CONNECTOR, FFC/FPC (ZIF) 30P
* CN6402	1-818-069-51	CONNECTOR, FFC/FPC (ZIF) 6P
* CN6403	1-573-915-51	CONNECTOR, FFC/FPC (ZIF) 6P
* CN6404	1-573-915-51	CONNECTOR, FFC/FPC (ZIF) 6P
CN6405	1-818-071-51	CONNECTOR, FFC/FPC (ZIF) 24P
		< DIODE >
* D6402	6-501-955-01	DIODE MAZS056G08S0
* D6403	6-501-476-01	DIODE NSSW008CT-T071 (BACKLIGHT)
* D6404	6-501-476-01	DIODE NSSW008CT-T071 (BACKLIGHT)
* D6405	6-501-476-01	DIODE NSSW008CT-T071 (BACKLIGHT)
		< TRANSISTOR >
Q6401	8-729-427-67	TRANSISTOR XP421F-TXE
Q6402	8-729-427-37	TRANSISTOR XP411F-TXE
		< RESISTOR >
R6402	1-218-955-11	RES-CHIP 1.5K 5% 1/16W
R6403	1-218-957-11	RES-CHIP 2.2K 5% 1/16W
R6404	1-218-959-11	RES-CHIP 3.3K 5% 1/16W
R6407	1-218-989-11	RES-CHIP 1M 5% 1/16W
		< VARISTOR >
* VD6401	1-802-279-11	VARISTOR (SMD)
* VD6402	1-802-279-11	VARISTOR (SMD)
* VD6403	1-802-279-11	VARISTOR (SMD)
* VD6404	1-802-279-11	VARISTOR (SMD)

Lista de peças da placa VC-537 não é mostrada.  
Páginas 5-13 a 5-17 não são mostradas.

• Refer to page 5-1 for mark △.

## VERIFICANDO OS ACESSÓRIOS FORNECIDOS

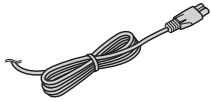

Cabo de Força  
△ 1-H00-045-05

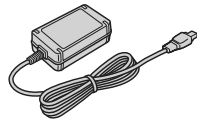

Adaptador AC  
(AC-L200/L200B)  
\* Compatível com  
L200 e L200B.  
△ 1-479-285-21



Manual de Instruções

4-H01-586-01

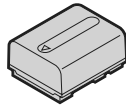

Bateria Recarregável  
(NP-FH30)  
△ A-1201-655-B



Cabo de conexão AV multi  
1-823-156-51

• Refer to page 5-1 for mark △.

## LISTA DE PARAFUSOS (1/6)

#1: M1.7 X 2.5  
(Black)  
2-635-562-11

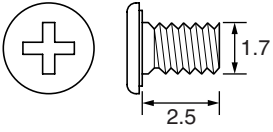

#2: M1.7 X 4.0  
(Black)  
2-635-562-31

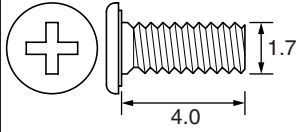

#3: M1.7 X 2.5  
(Red)  
2-660-401-01

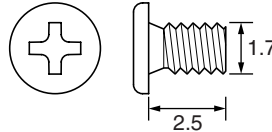

#4: M1.4 X 2.5 (Tapping)  
(Dark Silver)  
3-348-998-81

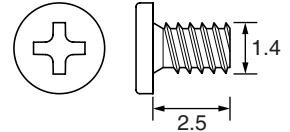

#5: M1.7 X 3.5 (Tapping)  
(Black)  
3-080-204-01

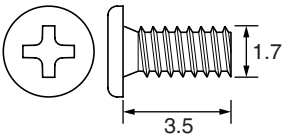

#6: M1.4 X 1.7  
(Silver)  
2-598-474-01

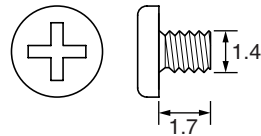

#7: M1.7 X 1.6  
(Black)  
7-627-552-18

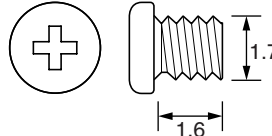

#8: M1.7 X 3.5 (Tapping)  
(Silver)  
3-078-890-01

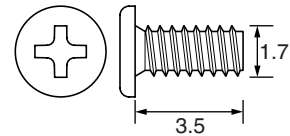

#9: M1.7 X 5.0 (Tapping)  
(Silver)  
3-078-890-21

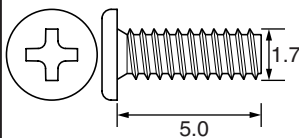

#10: M1.7 X 4.0  
(Silver)  
2-599-475-31

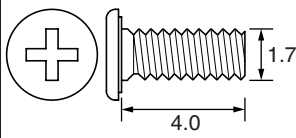

#11: M1.7 X 4.0 (Tapping)  
(Silver)  
3-078-890-11

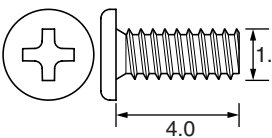

#12: M1.7 X 5.0 (Tapping)  
(Black)  
3-080-204-21

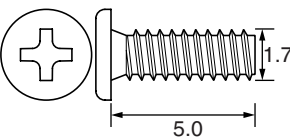

#13: M1.7 X 2.5 (Tapping)  
(Silver)  
3-085-397-01

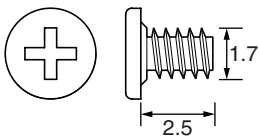

#14: M1.7 X 2.5  
(Silver)  
2-599-475-11

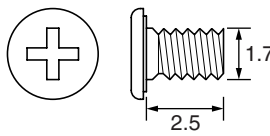

#15: M1.4 X 1.5  
(Silver)  
3-062-214-01

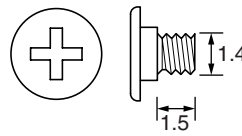

#16: M1.4 X 2.5  
(Silver)  
2-586-337-01

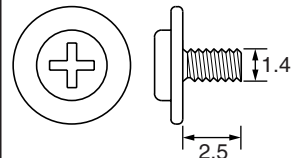

#17: M1.7 X 1.5  
(Silver)  
2-586-389-01

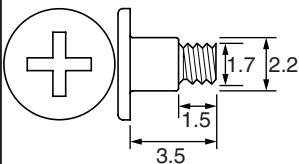

#18: M1.4 X 2.5  
(Silver)  
2-635-591-21

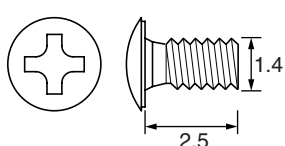

#19: M1.2 X 4.0 (Tapping)  
(Red)  
3-086-156-21

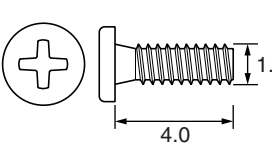

#20: M1.4 X 3.0  
(Silver)  
2-635-591-31

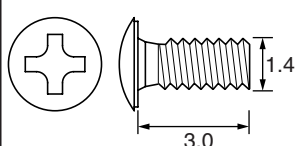

## LISTA DE PARAFUSOS (2/6)

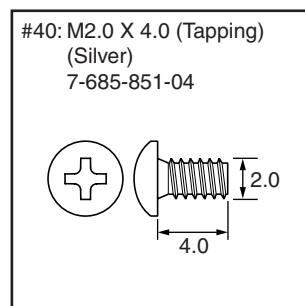
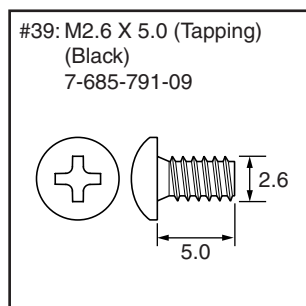
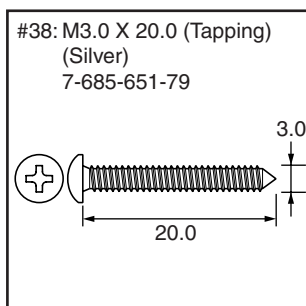
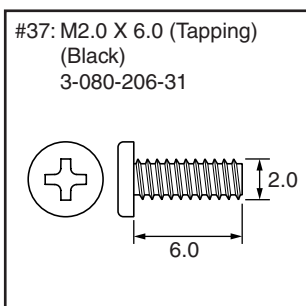
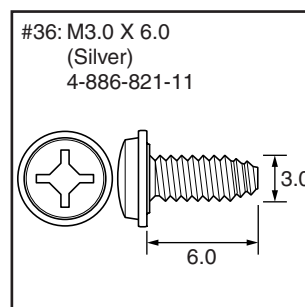
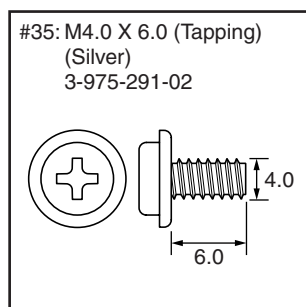
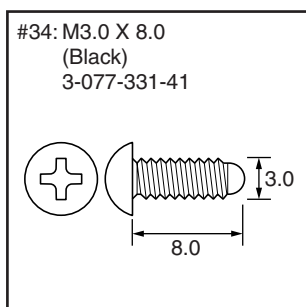
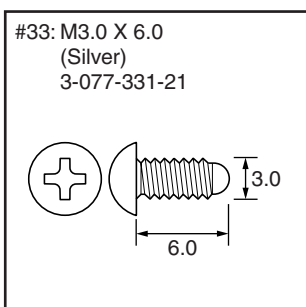
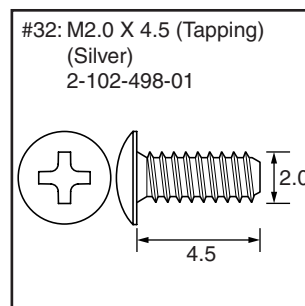
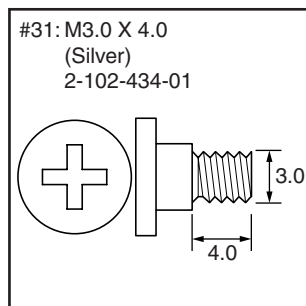
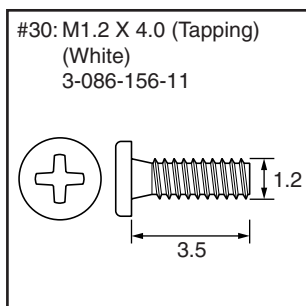
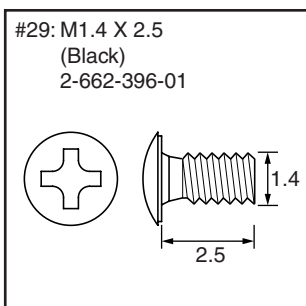
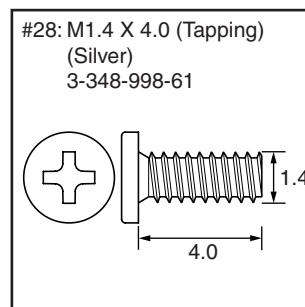
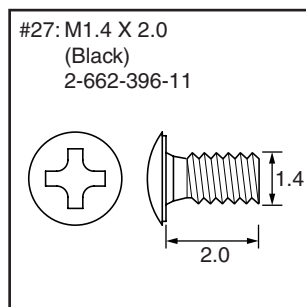
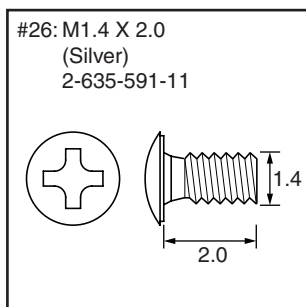
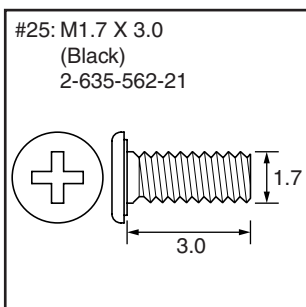
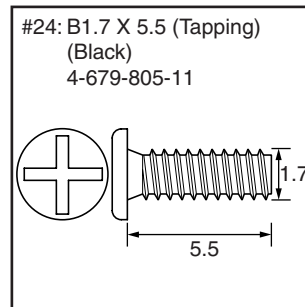
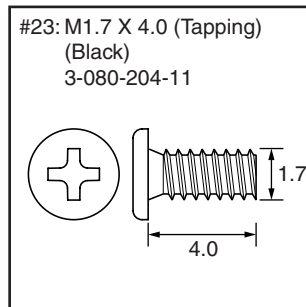
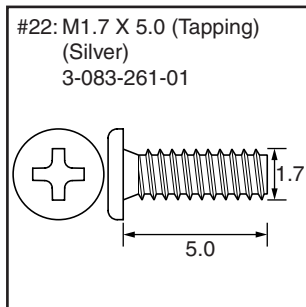
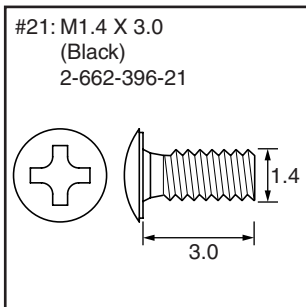

## LISTA DE PARAFUSOS (3/6)

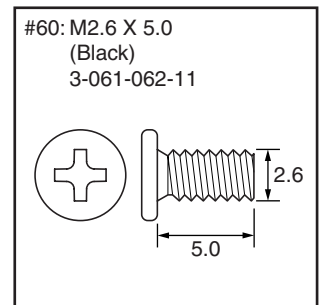
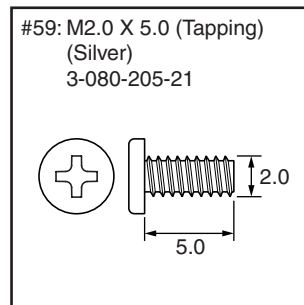
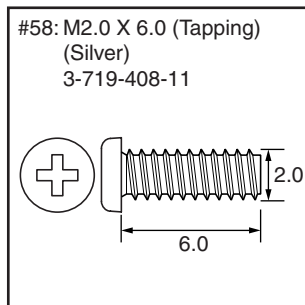
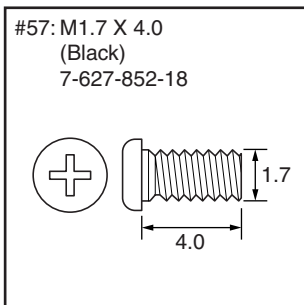
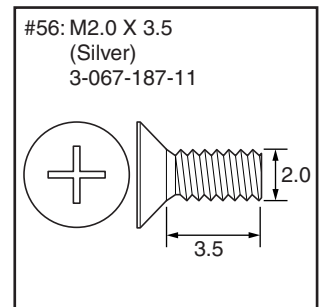
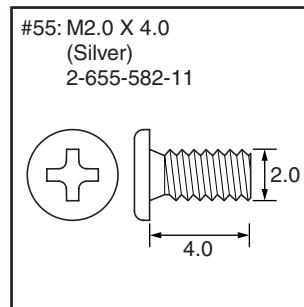
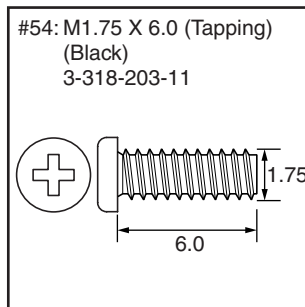
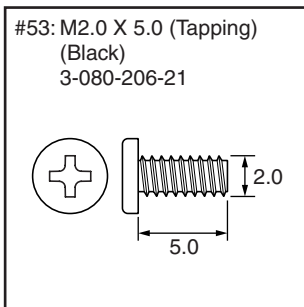
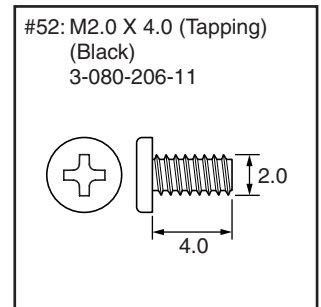
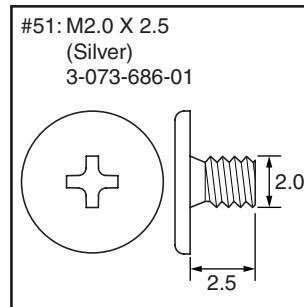
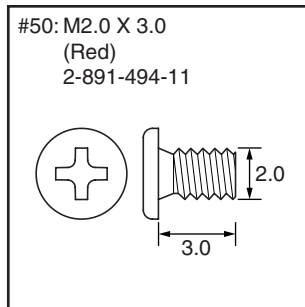
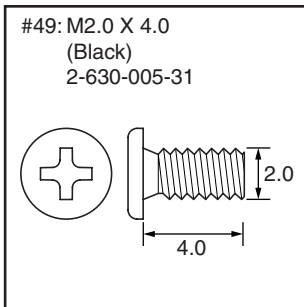
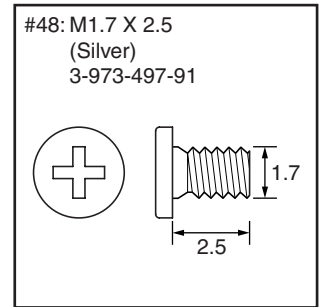
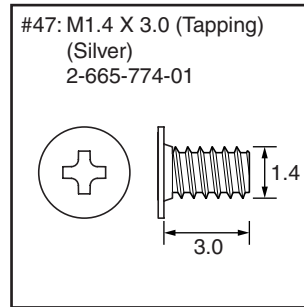
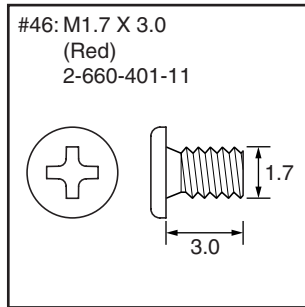
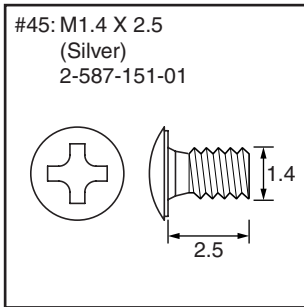
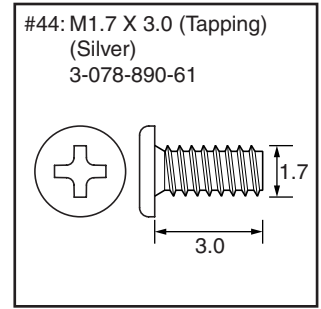
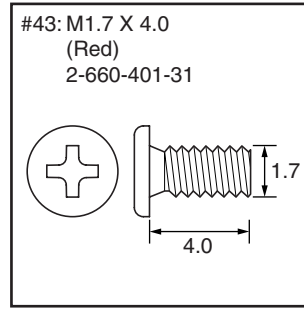
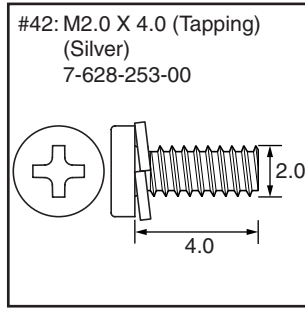
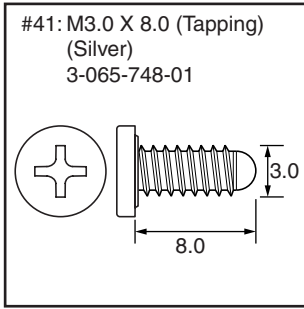



## LISTA DE PARAFUSOS (4/6)

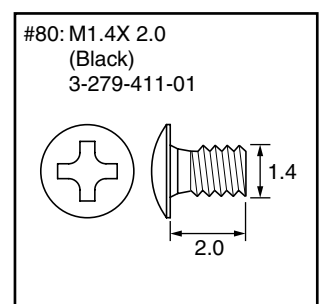
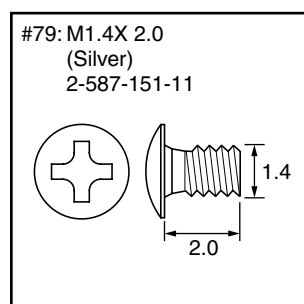
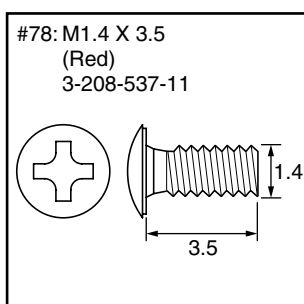
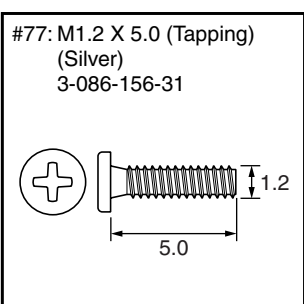
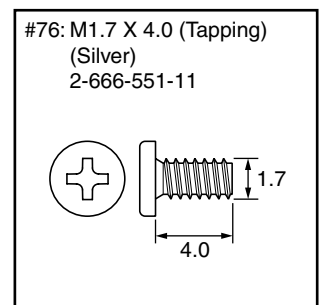
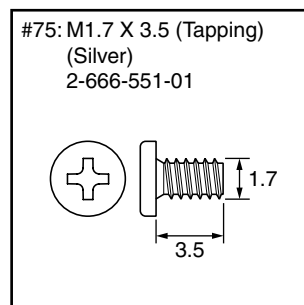
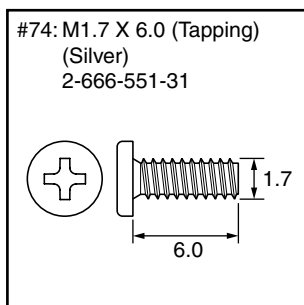
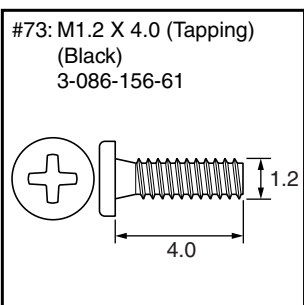
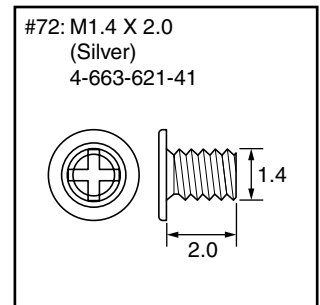
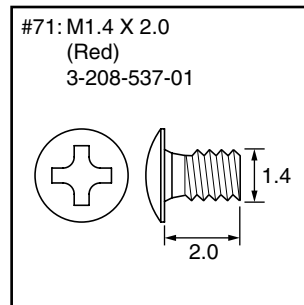
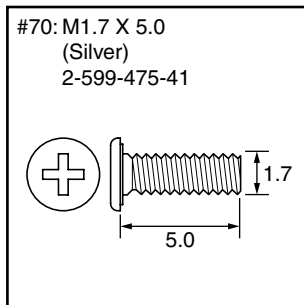
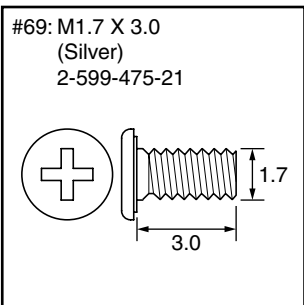
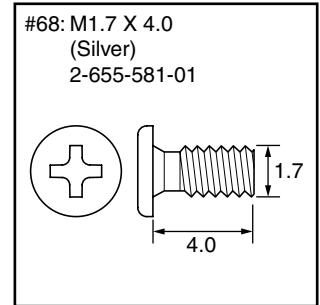
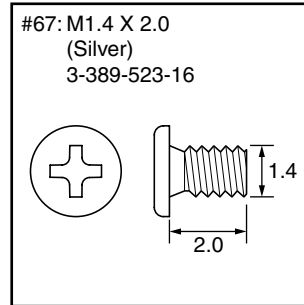
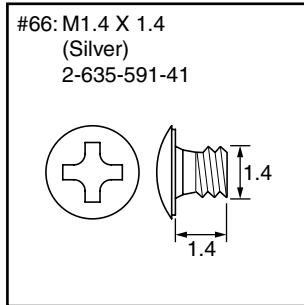
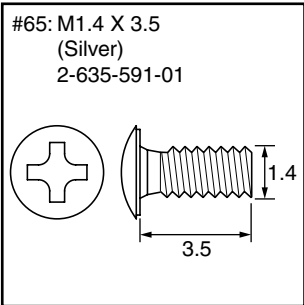
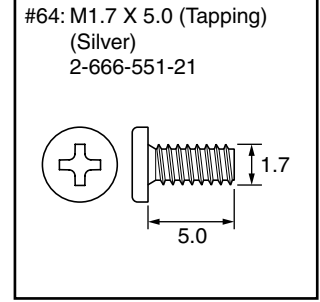
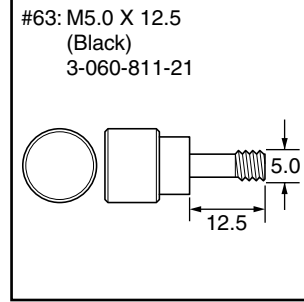
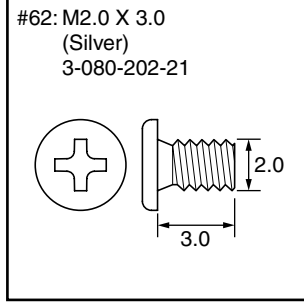
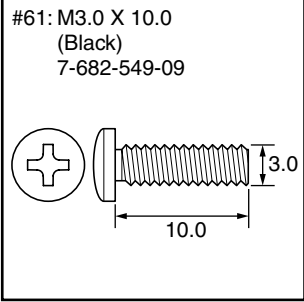

## LISTA DE PARAFUSOS(5/6)

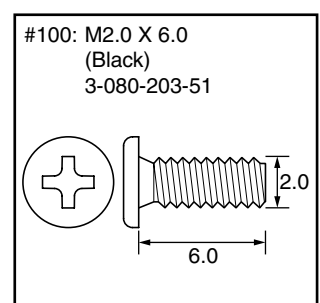
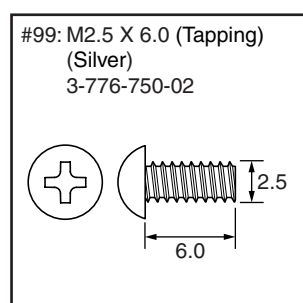
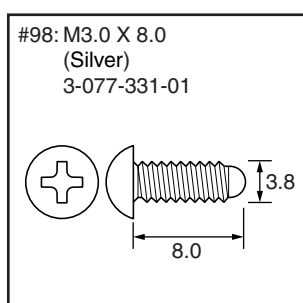
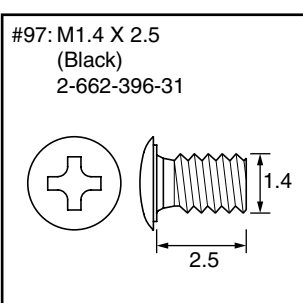
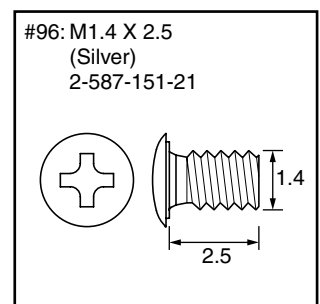
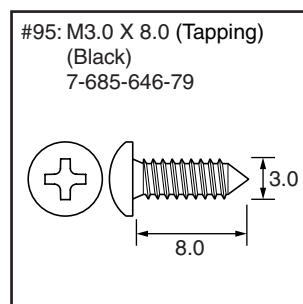
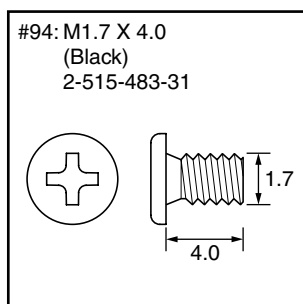
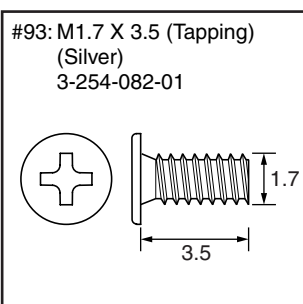
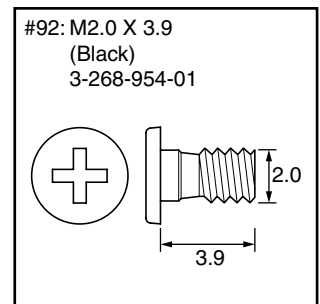
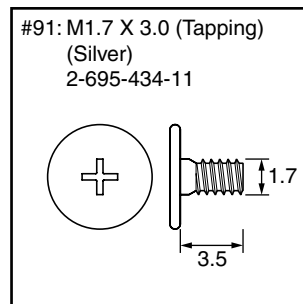
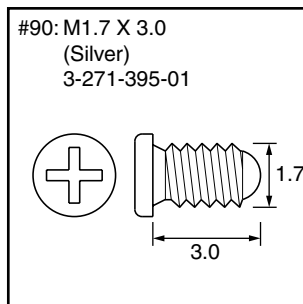
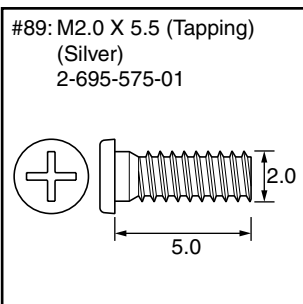
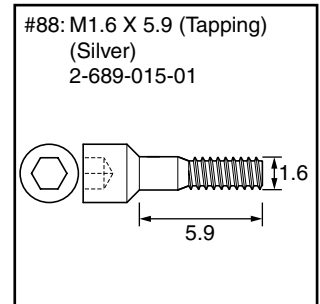
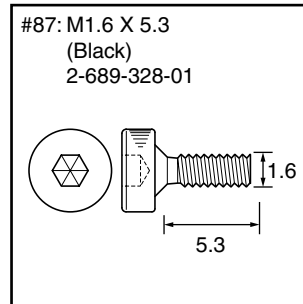
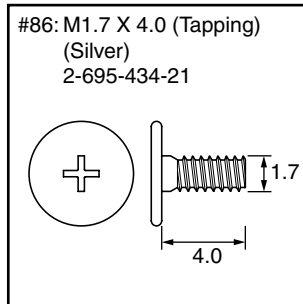
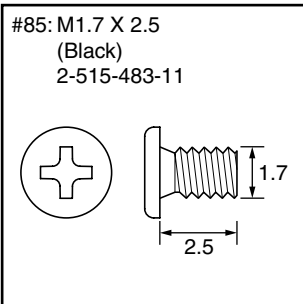
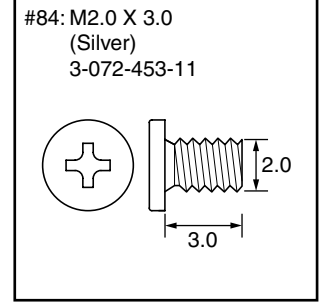
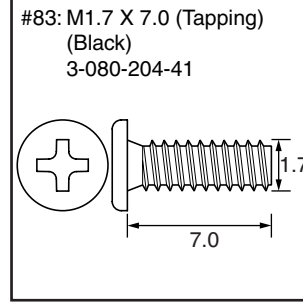
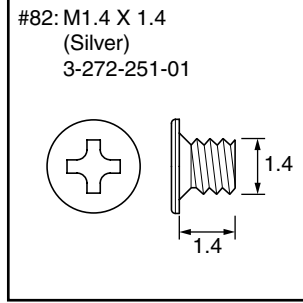
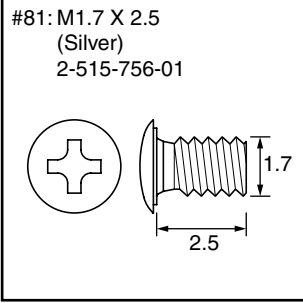

## LISTA DE PARAFUSOS (6/6)

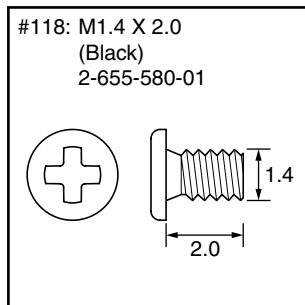
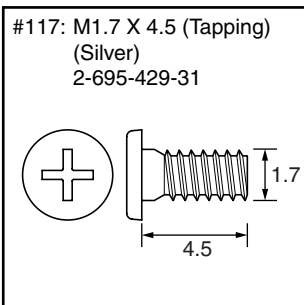
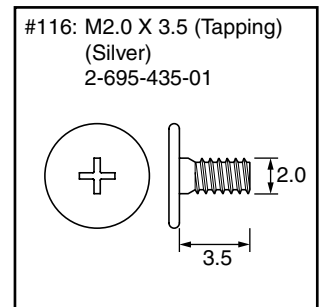
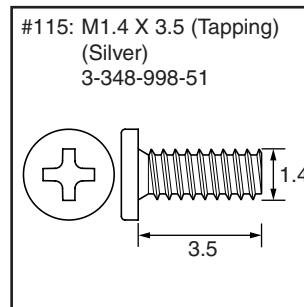
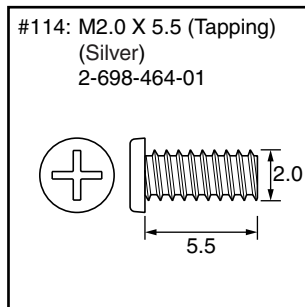
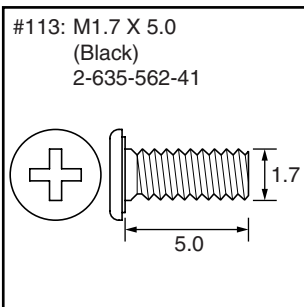
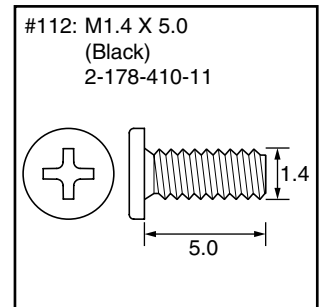
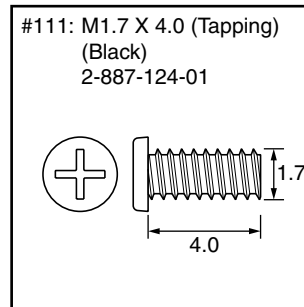
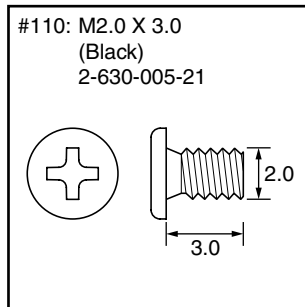
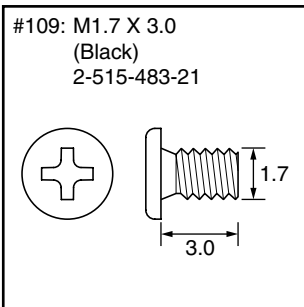
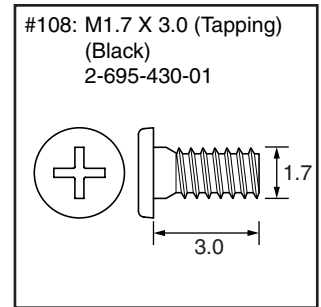
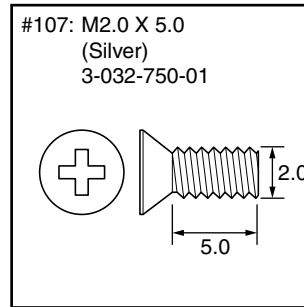
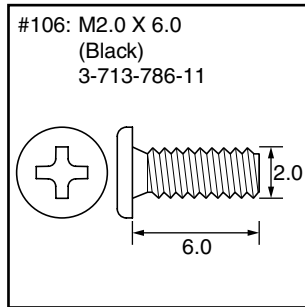
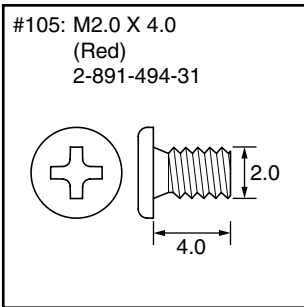
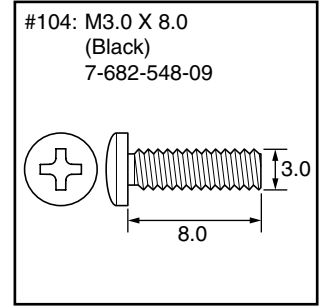
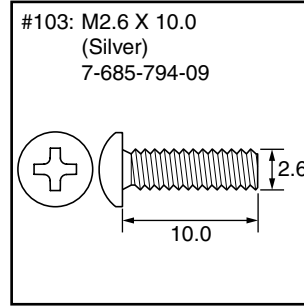
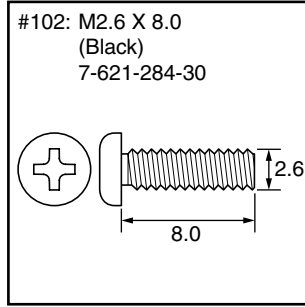
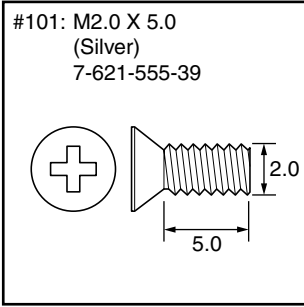

**SONY BRASIL LTDA.**  
**PRODUCT & QUALITY DIVISION**  
**Fevereiro / 2008**

<http://www.sony.com.br>



# Guia de Comandos Básicos do Acrobat Reader 5.05



# Adobe® Acrobat® 4.0

Esta é a tela do programa, quando se abre um manual:

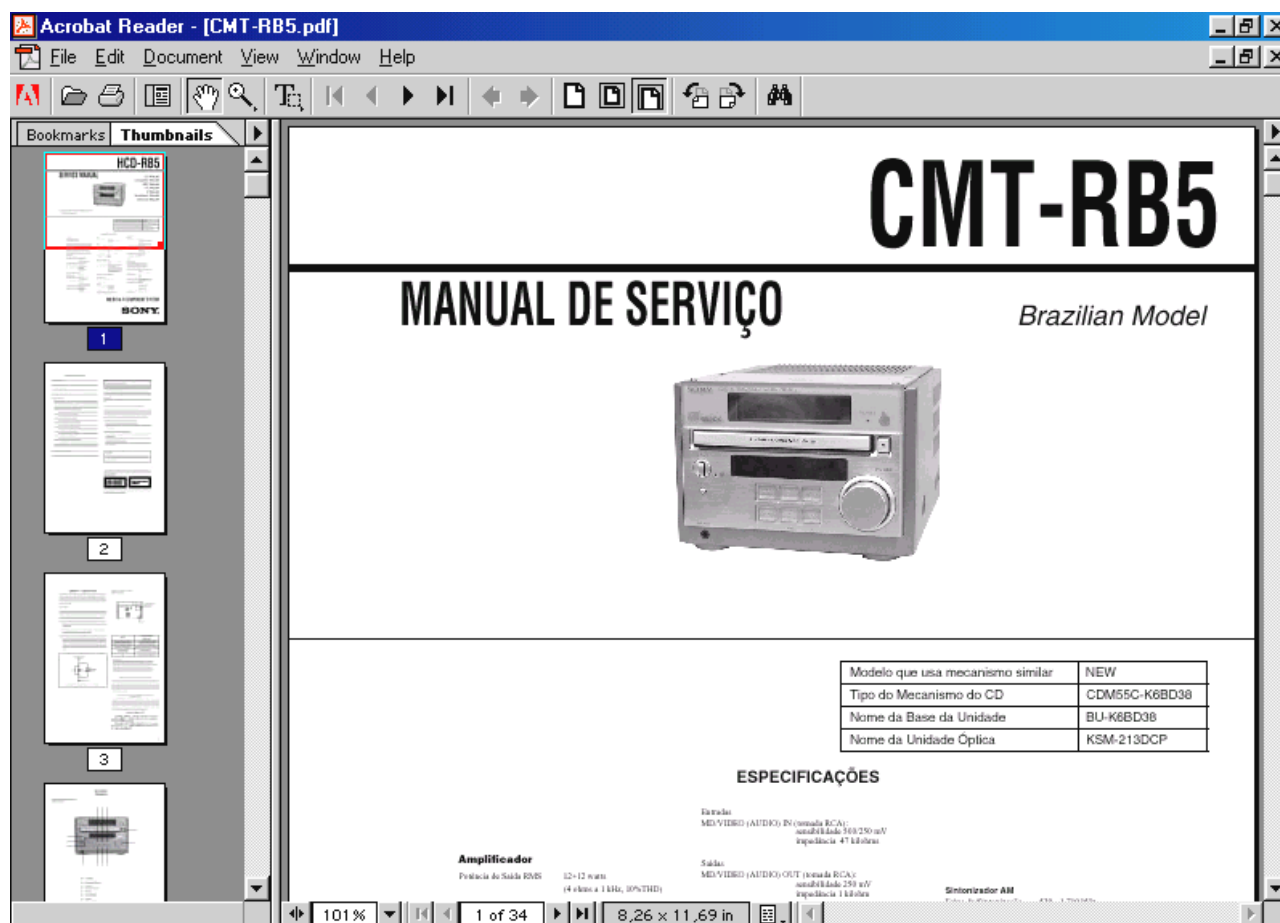

## Barra de Comandos

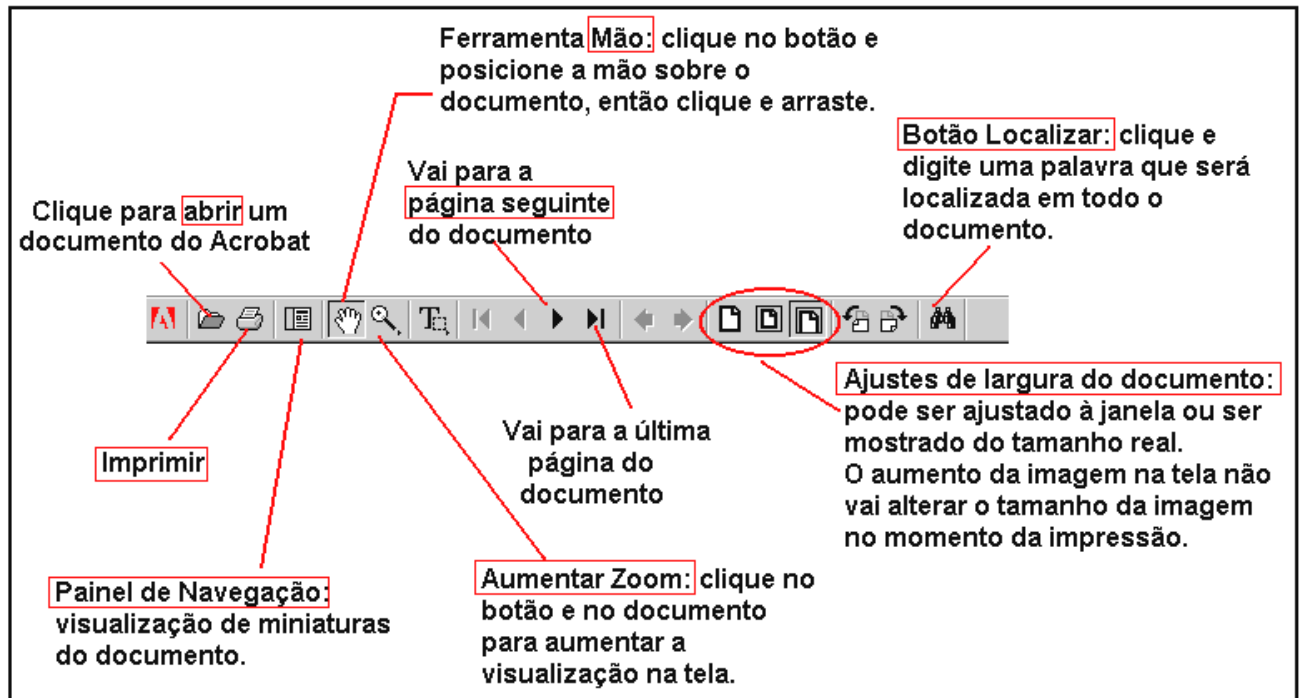

## Recurso de Localização de Componentes

Alguns manuais de serviço estão habilitados com uma função que permite localizar mais facilmente um circuito integrado (IC) em seu diagrama esquemático correspondente, diagrama em blocos ou placa de circuito impresso.

Para isso, abra um manual de serviço, por exemplo o do MHC-DX30 e visualize uma página da lista de peças elétricas, onde existam alguns IC's listados. Ao posicionar o ponteiro do mouse sobre a linha onde está um IC, sobre sua localização, ou valor, você vai verificar que aparece uma "mãozinha", na verdade, o dedo indicador que fica apontando a linha. Se você der um clique, você será levado pelo programa à página do diagrama esquemático onde se encontra o referido IC que você selecionou. Vamos ilustrar o que foi explicado logo a seguir:

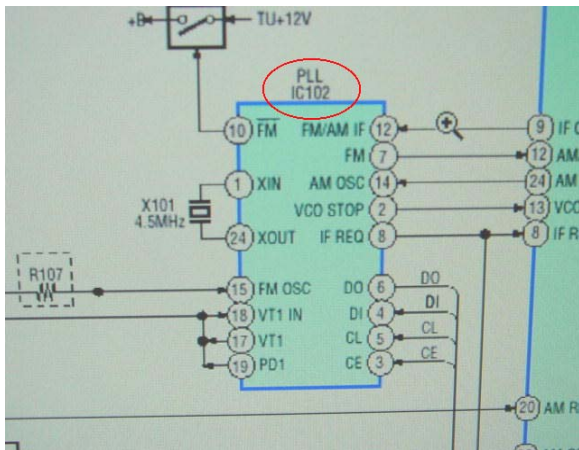

Abra a página correspondente ao diagrama em bloco e posicione o ponteiro do mouse sobre o IC escolhido. Quando o cursor tornar-se uma "mãozinha" dê um clique sobre o IC.

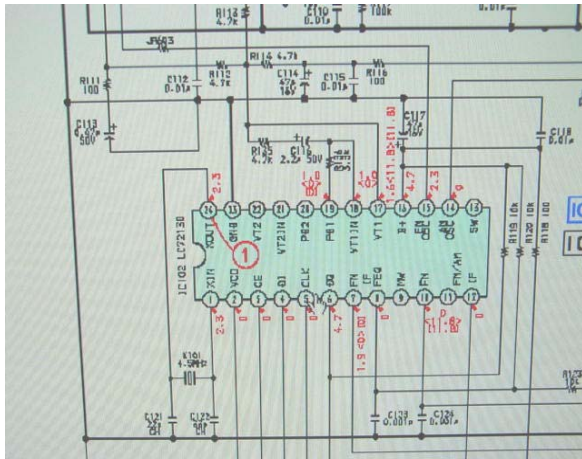

O programa trará você à página do diagrama esquemático correspondente que contém o IC escolhido. Clique novamente sobre o IC.

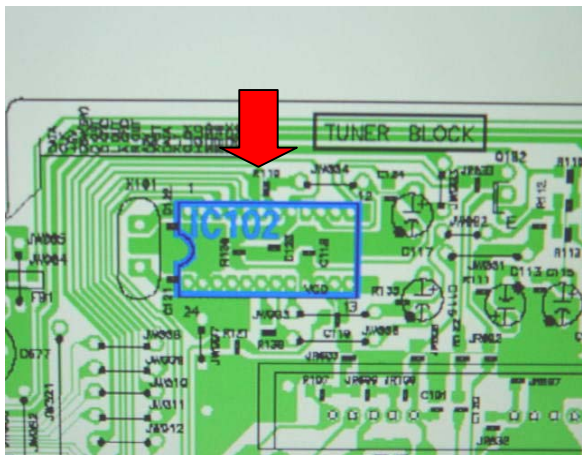

O programa trará você à página correspondente a placa de circuito impresso que contém o IC escolhido. Clique novamente sobre o IC.

* GND1 1-537-738-21 TERMINAL, EARTH		
< IC >		
IC101	8-759-652-00	IC BA1450
IC102	8-759-288-54	IC LC72130
IC201	8-759-242-58	IC TA8189N
IC301	8-759-832-80	IC BH3878KS2
IC401	6-800-194-01	IC M30622MCA-B23FP
IC661	8-759-635-46	IC M51943BSL-TP
IC681	8-759-039-69	IC uPC7805AHF
IC682	8-759-039-69	IC uPC7805AHF
IC683	8-759-088-08	IC uPC7812AHF
IC684	8-759-604-31	IC M5F7809L

Por fim o programa visualiza o ponto da lista de peças onde o IC escolhido está localizado. Ao clicar novamente sobre o componente o ciclo se repete (diagrama em bloco, esquemático, placa de circuito impresso e lista de peças. Vale lembrar que nem todos os manuais de serviço possuem esse recurso.

## Notas

- O tamanho da visualização do documento na tela em nada altera o tamanho de impressão. O Zoom de aumento ou de diminuição serve apenas para oferecer mais detalhes ou um aspecto geral do documento visualizado.

- O painel de navegação serve para agilizar o acesso a outras páginas que não estão sendo visualizadas. Para visualizar uma dessas miniaturas em seu tamanho normal, basta clicar duas vezes sobre ela e então esta será exibida na tela.
- Não é possível alterar texto, figuras ou qualquer item do documento no Acrobat Reader 5.0. Este programa é usado somente para visualização e impressão de documentos PDF.
- Diagramas e demais folhas do documentos PDF só poderão ser impressos em tamanho maior caso a impressora suporte papel com dimensão superior ao A4, carta ou semelhante. Do contrário só poderá ser impresso no tamanho A4 padrão.

## **Engenharia da Qualidade – Novembro 2003**

*teruaki\_nakagawa@ssp.br.sony.com*



## Orientação de Impressão no Acrobat Reader 5.05

**Acrobat® Reader™ 5.0**  
 Saiba mais no endereço [www.brasil.adobe.com/acrobat](http://www.brasil.adobe.com/acrobat)

Copyright © 1987-2001 Adobe Systems Incorporated e seus outorgantes. Todos os direitos reservados. Adobe, o logotipo Adobe, Acrobat, o logotipo Acrobat, PostScript e o logotipo PostScript são marcas registradas ou comerciais da Adobe Systems Incorporated nos Estados Unidos e/ou outros países.

Dê o primeiro passo! Adquira o Acrobat 5.0 e:

- Converta facilmente os documentos para Adobe PDF
- Compartilhe comentários e aprove ou proteja documentos com eficiência

**Emuito mais!**

*É possível imprimir alguns quadros pré-selecionados de forma ampliada no Acrobat Reader. Esse comando é muito útil quando é necessária fazer a impressão de diagramas elétricos.*

*A sequência abaixo mostra, passo a passo como selecionar uma parte de uma folha qualquer (nesse exemplo usaremos um diagrama elétrico) e configurar sua impressão.*

Temos no Acrobat Reader a barra abaixo. Leve o cursor do mouse até o botão indicado pela seta e fique pressionando o botão do mouse.

Segurando o botão uma barra oculta aparecerá, então expanda conforme abaixo. O botão final a ser clicado para que o comando seja selecionado é o da **FERRAMENTA DE SELEÇÃO DE GRÁFICO (G)**

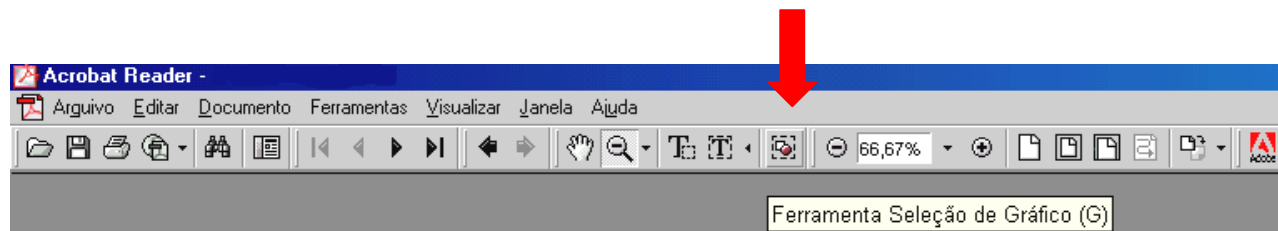

Agora com o cursor selecione uma área do diagrama que deseja imprimir de forma ampliada. A área escolhida nesse exemplo é o quadrado de linhas espessas.

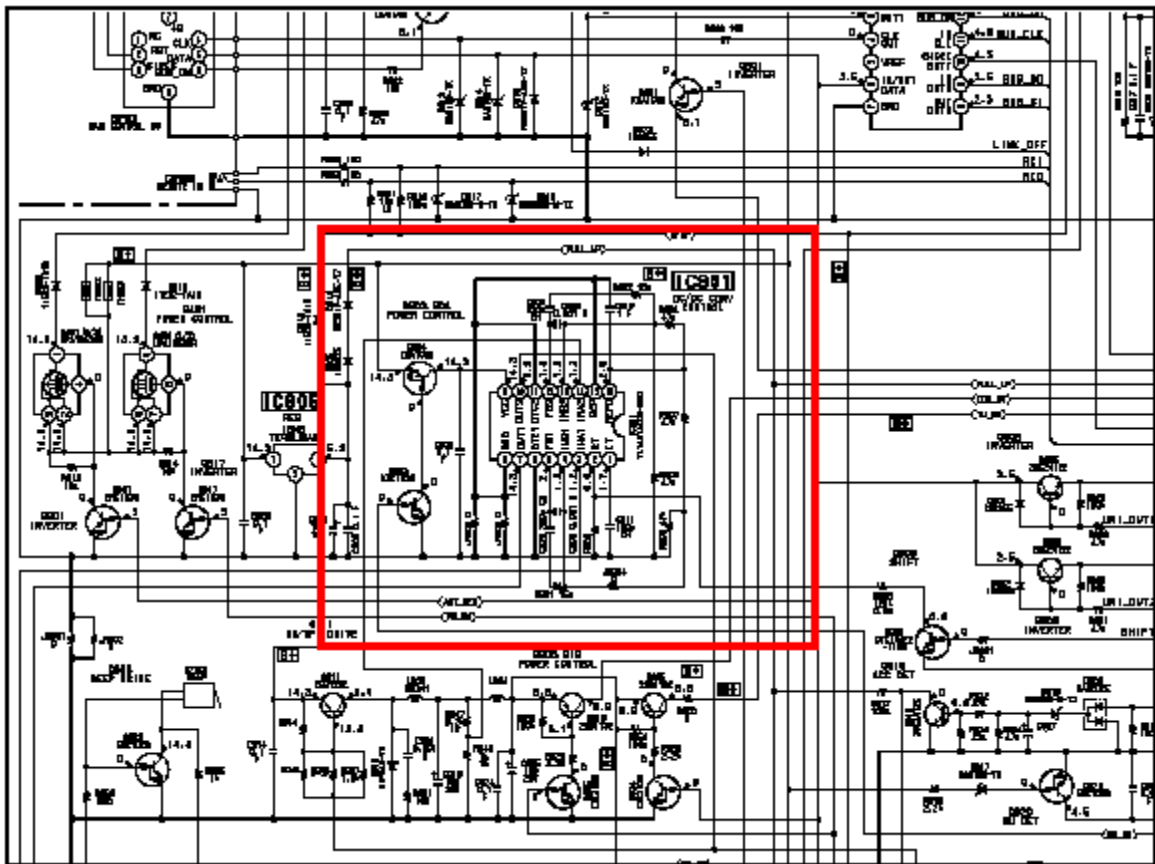

Agora vá até o menu de impressão seguindo o procedimento a seguir, clicando em **IMPRIMIR**, indicado pela seta:



Na janela que se abre verifique se as opções indicadas em vermelho (circuladas) estão habilitadas. Assim, quando imprimir a área do gráfico, esta parte será expandida por toda a folha de papel A4.

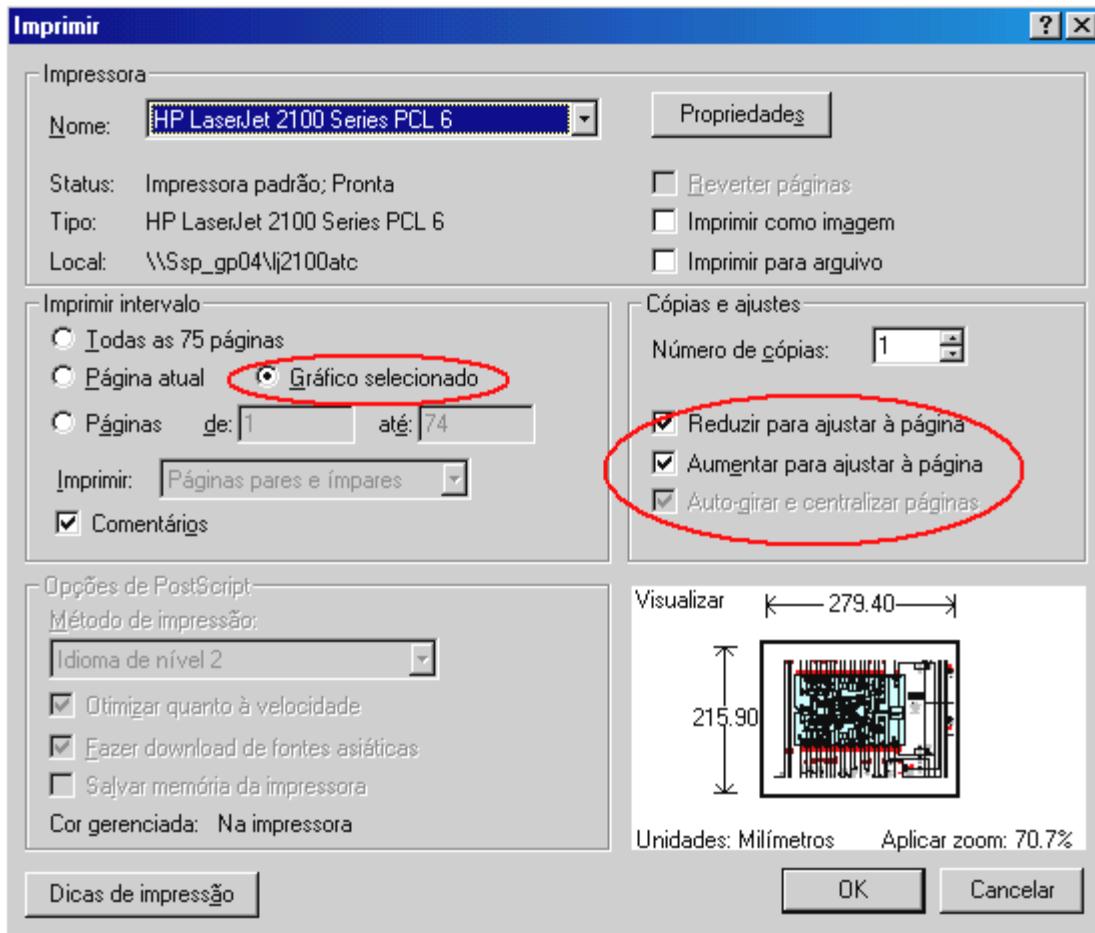

Após a impressão verificamos que o diagrama ficou realmente ampliado, conforme exemplo:

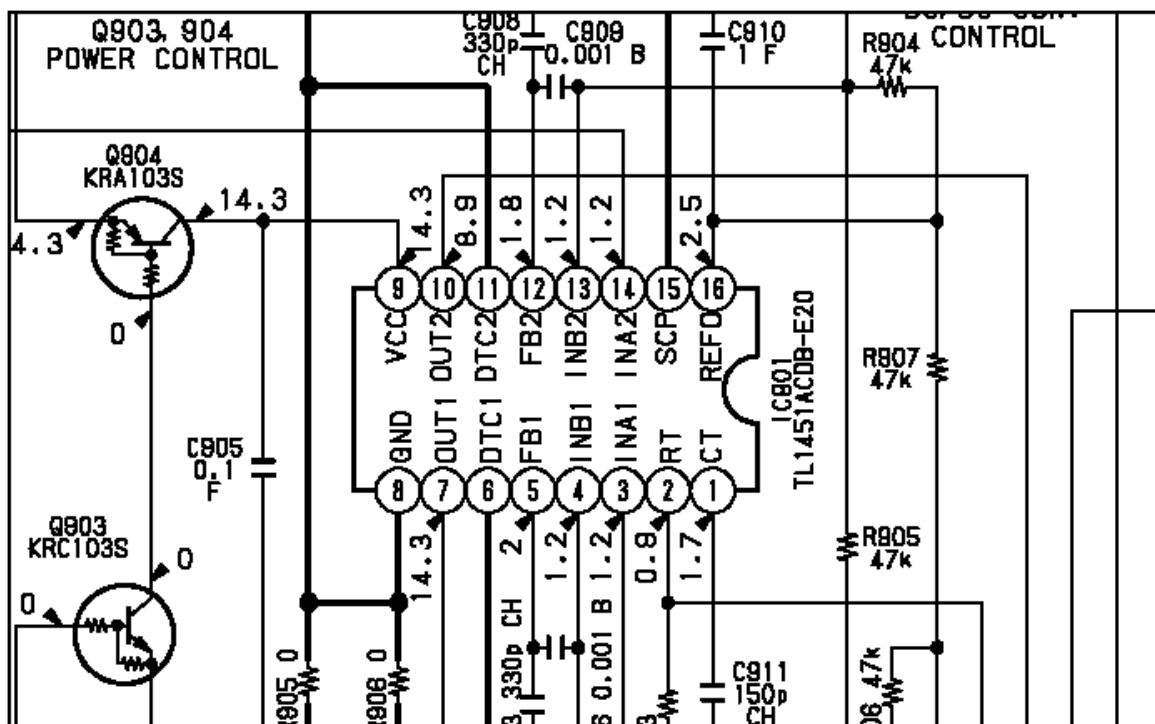

## Notas

O mesmo procedimento pode ser repetido para outras páginas dos manuais, como lista de peças, bem como pode ser utilizado papel tamanho A3 (420 x 297 mm) para impressoras que suportem esse formato.

Outros comandos podem ser encontrados no “**Guia de Comandos Básicos do Acrobat Reader**”, que também consta neste CD e em anteriores.

Lembramos novamente que não é possível alterar texto, figuras ou qualquer item do documento no Acrobat Reader 5.05. Este programa é usado somente para visualização e impressão de documentos PDF.

Mais informações podem ser obtidas em “**Ajuda**”.

Dúvidas e sugestões devem ser encaminhadas para **Teruaki** através do e-mails:



[teruaki\\_nakagawa@ssp.br.sony.com](mailto:teruaki_nakagawa@ssp.br.sony.com)